



# Protection of superconducting accelerator magnets

M. Marchevsky

Lawrence Berkeley National Laboratory

# Outline

- What we are protecting magnets from?  
*The stored energy of a superconducting magnet and its release in a quench*
- What can cause a superconducting magnet to quench?  
*Energy “disturbance”*
- How do we detect a quench?  
*Voltage and non-voltage-based quench detection methods*
- How do we act upon detecting quench?  
*Magnet protection methods and circuits*

# Stored energy of a superconducting magnet

Magnet is an inductor, hence:  $E = \frac{LI^2}{2} = \frac{\mu_0}{2} \int B^2 dV$

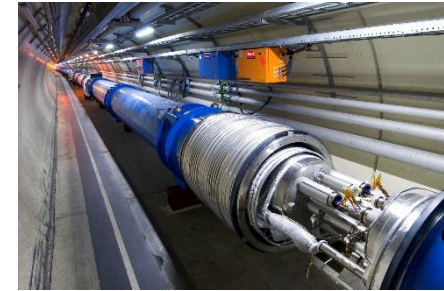

- The 14-m long LHC dipole has a stored energy of **7 MJ** at the design field of 8.4 T
- Smaller scale (~1 m long) prototype accelerator dipoles and quadrupoles at their operational current are typically in 0.5-0.7 MJ range and it **can be released in a matter of milliseconds!**



60 mph

- 0.7 MJ is energy of a car (2000 kg) moving at 60 mph
- 0.7 MJ of energy is sufficient to heat up from 4 K and melt ~1 kg of copper!
- Equivalent He gas release is 254 L / kJ => 177.8 m<sup>3</sup> of gas!  
If the gas cannot be released quickly.... ->



# What is a quench?

A formation of an **unrecoverable** normal zone within a superconductor

Quenching will convert **energy supplied by the current source AND magnet stored energy into heat.**

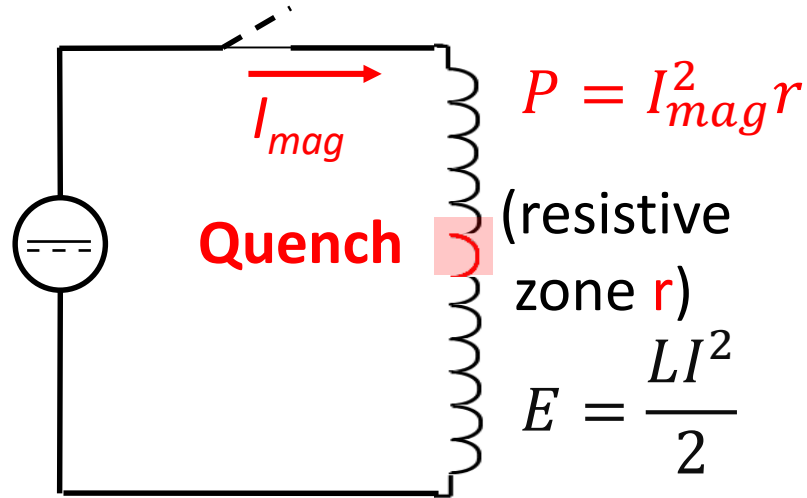

- When quench occurs, energy release is **localized** in the normal zone of the conductor!
- If that zone is small in volume, quench may lead to unreparable magnet damage of the magnet windings or other electrical infrastructure (splices, current leads, etc...).
- **Quench protection** is an array of techniques used to prevent such damage from occurring.

Quench protection sequence:

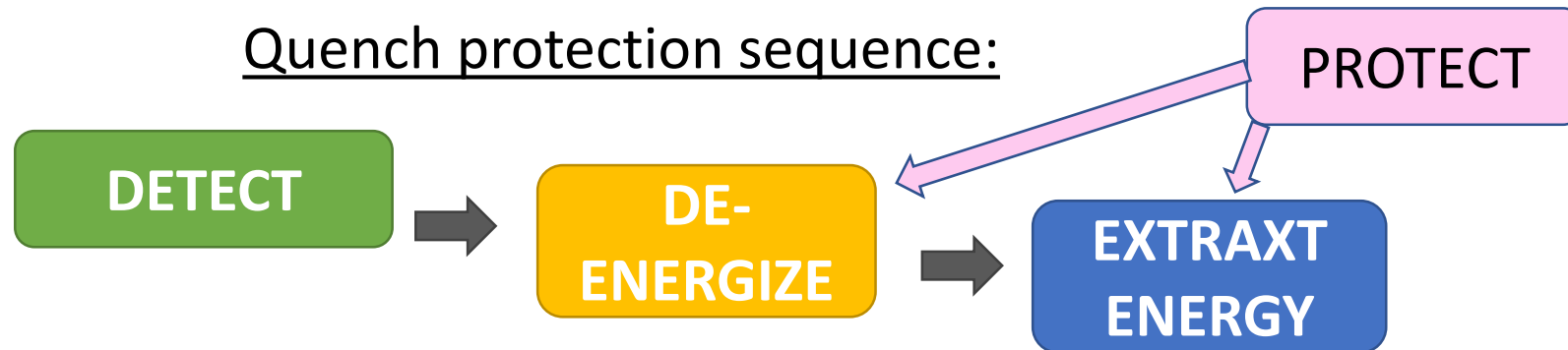

# Quench in small-scale accelerator magnet



(movie)

Quench in the CCT3 dipole (~ 80 kJ of stored energy)

Quench-related damage in the coil of HQ01 quadrupole

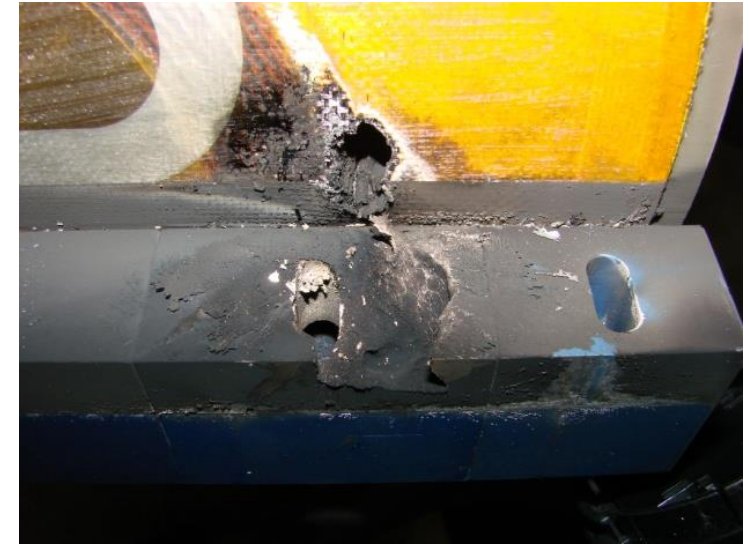

# Onset of a quench: minimum propagating zone

It only takes a small volume fraction of a current-carrying superconductor to be heated above its transition temperature to start a quench.

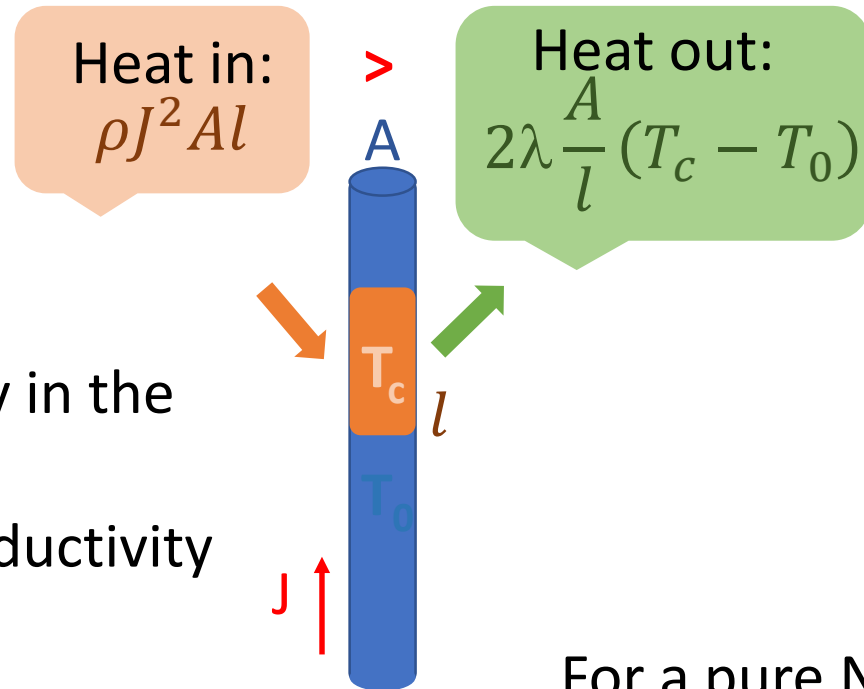

$$l_{mpz} = \sqrt{\frac{2\lambda(T_c - T_0)}{\rho J^2}}$$

3D case:

$$d_{mpz} = \pi \sqrt{\frac{2\lambda(T_c - T_0)}{\rho J^2}}$$

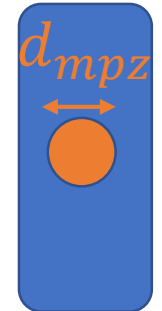

For a pure NbTi wire (no stabilizer):  $l_{mpz} \sim 1 \mu\text{m}$

For a multi-filamentary NbTi strand:  $l_{mpz} \sim 1 \text{mm}$

Given that specific heat of metals at low temperatures is  $\sim 1000$  times less than at room temperature, this  $l_{mpz}$  yields a very small amount of heat needed to start a quench...

# Minimum quench energy

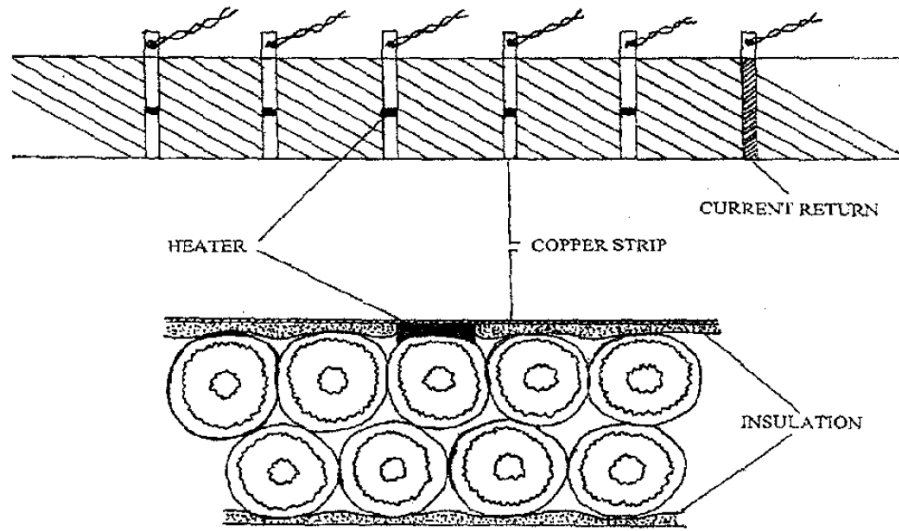

Fig 2. Schematic of the heater location on a strand in the cable.

A.K. Ghosh et al., 1997

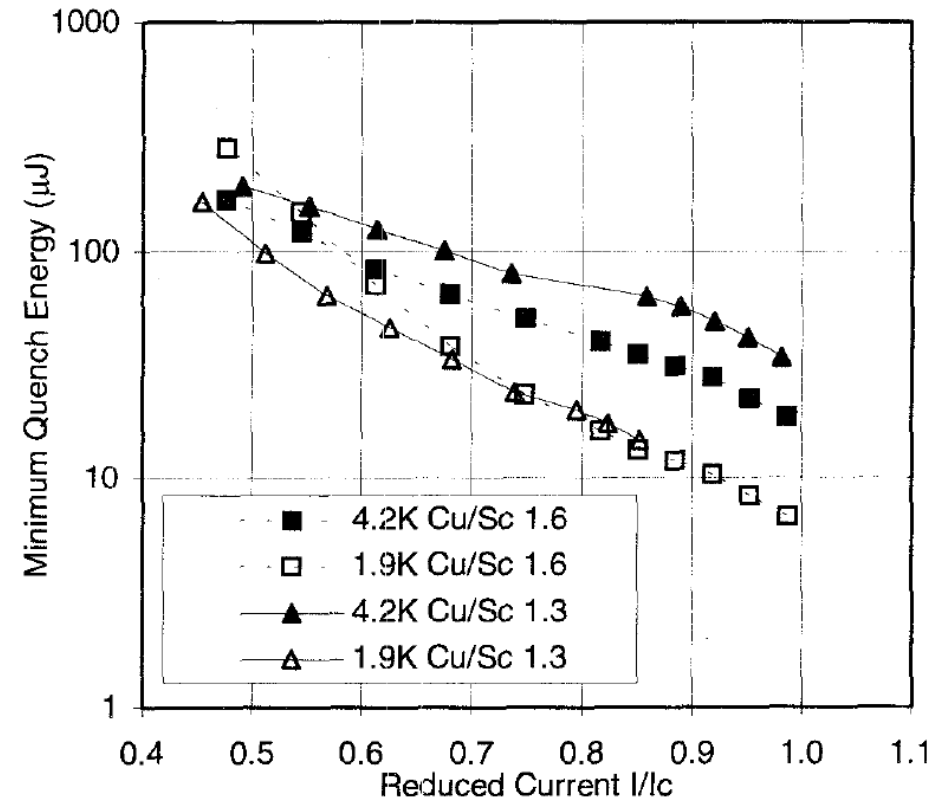

Fig. 3. MQE for two LHC type strands with different Cu/Sc ratio.

- 10  $\mu\text{J}$  is the kinetic energy of a staple dropped from a 3 cm height....
- ...and is  $\sim 10^{11}$  -  $10^{12}$  times less than a stored energy of a typical accelerator magnet!

# What can start a quench?

## ■ Intrinsic

- Conductor instability with respect to flux jumps
- Conductor damage / broken strands
- AC losses

## ■ Mechanical

- Motion of the conductor
- Cracking and delamination of impregnation epoxy

## ■ Thermal

- Excess heating in splices or current leads
- External heat leaks
- Nuclear and beam radiation

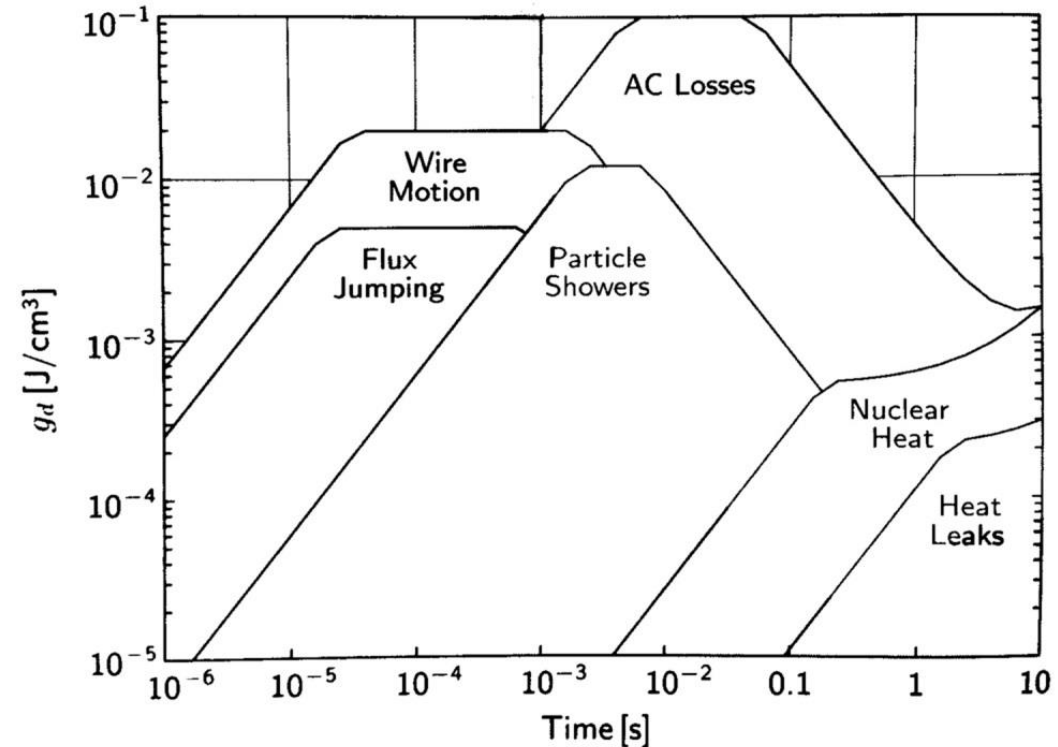

Disturbance spectra of accelerator magnets

(Y. Iwasa, "Case Studies in Superconducting magnets", Springer 2009)

**Quenching is usually considered a natural part of the magnet operation, and magnet systems should be designed to handle it safely.**



# Note on beam losses and quenching

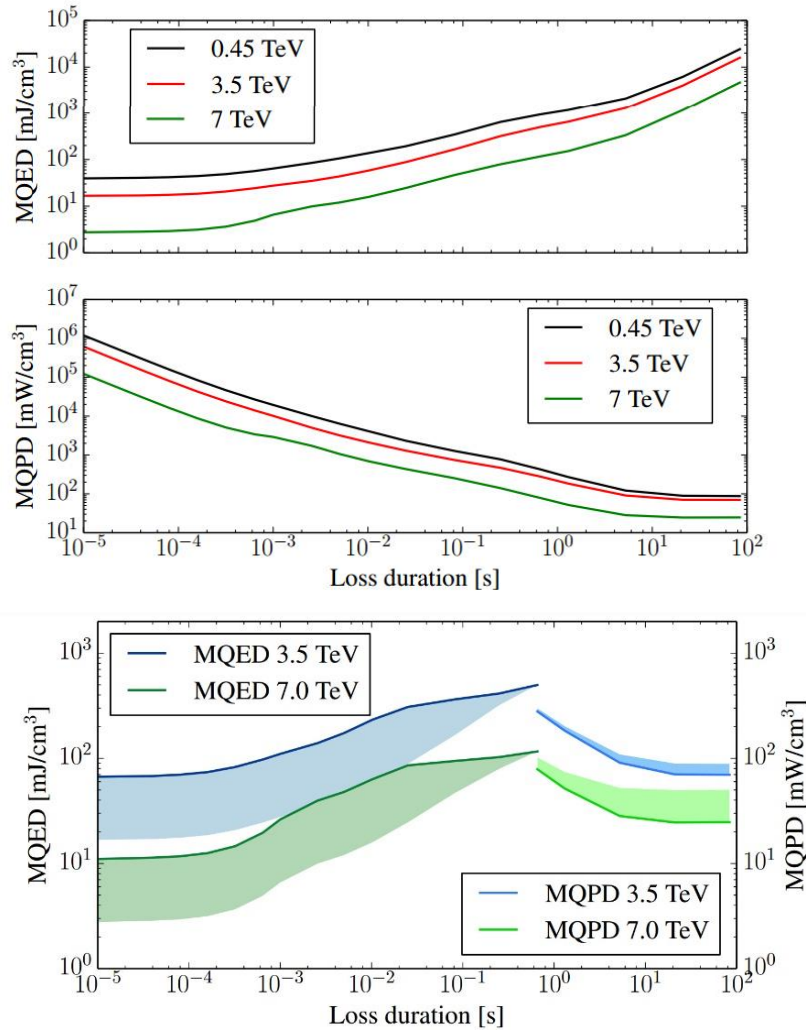

- **Short-duration ( $t < 50 \mu\text{s}$ ):** The local quench level is determined predominantly by the volumetric heat capacity of a dry cable. The quench level in this regime is quantified by the Minimum Quench Energy Density (MQED).
- **Intermediate-duration ( $50 \mu\text{s} - 5 \text{s}$ ):** The liquid helium in the cable interstices and, to a lesser extent, around the insulated conductor plays a crucial role.
- **Steady-state ( $t > 5 \text{s}$ ):** The heat is constantly removed with a rate that is mainly determined by the heat transfer to the helium bath through the cable insulation. The quench level, is expressed as a Minimum Quench Power Density (MQPD).

“Testing beam-induced quench levels of LHC superconducting magnets”,  
 B. Auchmann *et al.* Phys. Rev. ST Accel. Beams **18**, 061002 (2015)

# Quench propagation: 1D model



Heat balance:

$$C \frac{dT}{dt} = \lambda \frac{d^2T}{dz^2} + g(J, T),$$

Heat capacity
Heat conductivity
Ohmic heat generation

Substituting:  $\xi = z - vt$

$$\lambda \frac{d^2T}{d\xi^2} + Cv \frac{dT}{d\xi} + g(\xi) = 0, \quad g(\xi) = \begin{cases} \rho J^2, & \xi < 0 \\ 0, & \xi > 0 \end{cases}$$

General solution for the equation:

$$T(\xi) = \begin{cases} T_c - (T_c - T_w) \exp(\alpha\xi), & \xi < 0 \\ T_0 - (T_w - T_0) \exp(-b\xi), & \xi > 0 \end{cases} \quad \text{- a travelling wave solution}$$

Then, substituting into the heat equation:  $v_0 = \frac{J}{C} \sqrt{\frac{\rho\lambda}{T_c - T_0}}$

Assuming  $C \sim T^3$  :  $v = v_0 \sqrt{\frac{4T_0^5(T_c - T_0)}{T_c^2(T_c^4 - T_0^4)}}$  Dresner, 1994

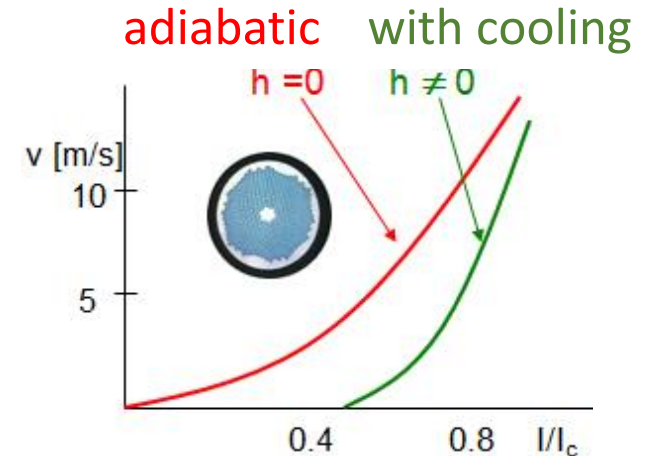

# Quench propagation in 3D

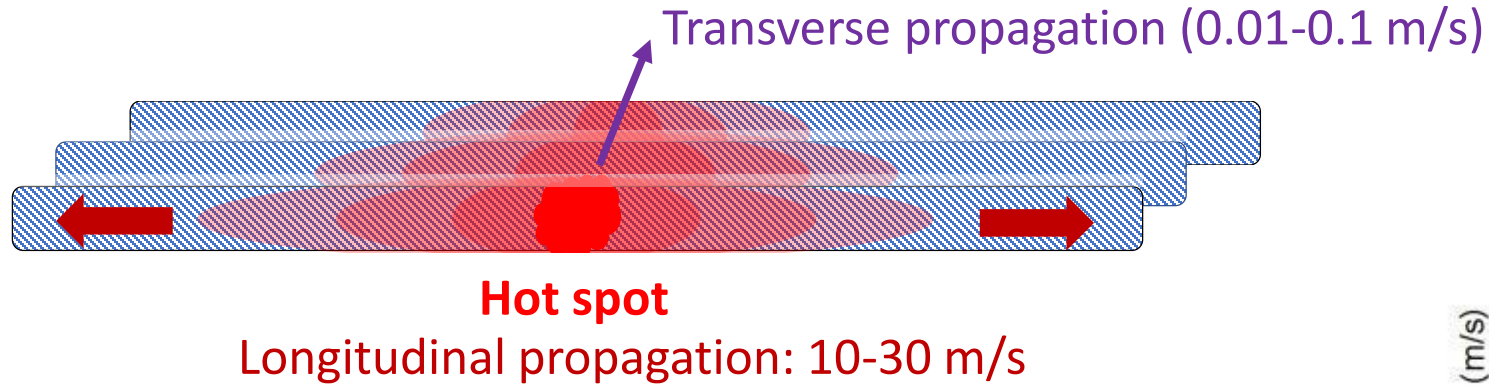

Resistance increase in the coil caused by the expansion of the normal zone AND continuing temperature increase within the normal zone

The total coil resistance can be found by integrating  $\rho(T,B)$  over the normal volume

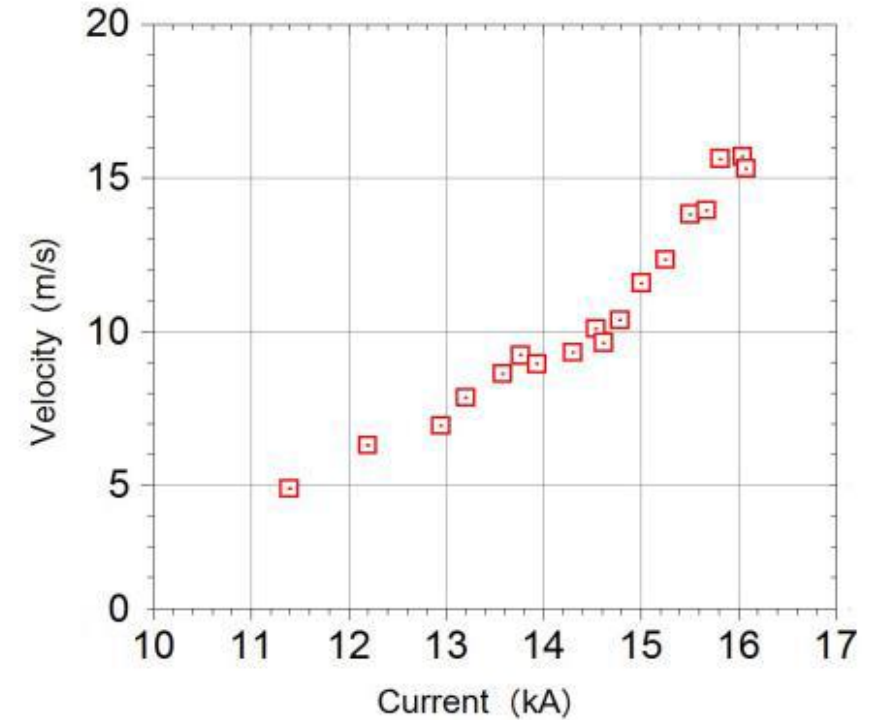

Quench propagation velocity measurements in HD3 high-field dipole ( $I_{ss}=18.7$  kA)

# Quench simulations: FEA

ANSYS – thermal electrical model

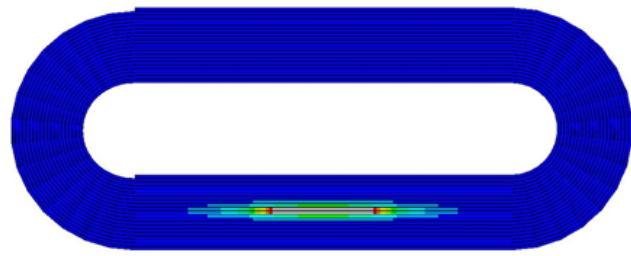

Tmax = 24 K      Time = 30 ms

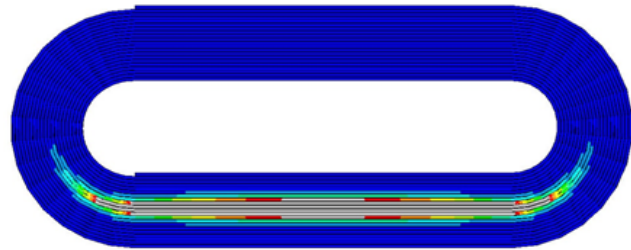

Tmax = 44 K      Time = 80 ms

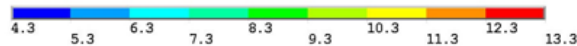
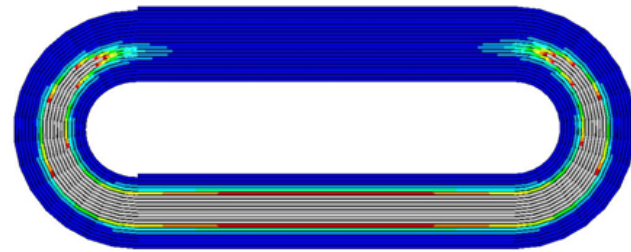

Tmax = 62 K      Time = 130 ms

*P. Ferracin, 2009*

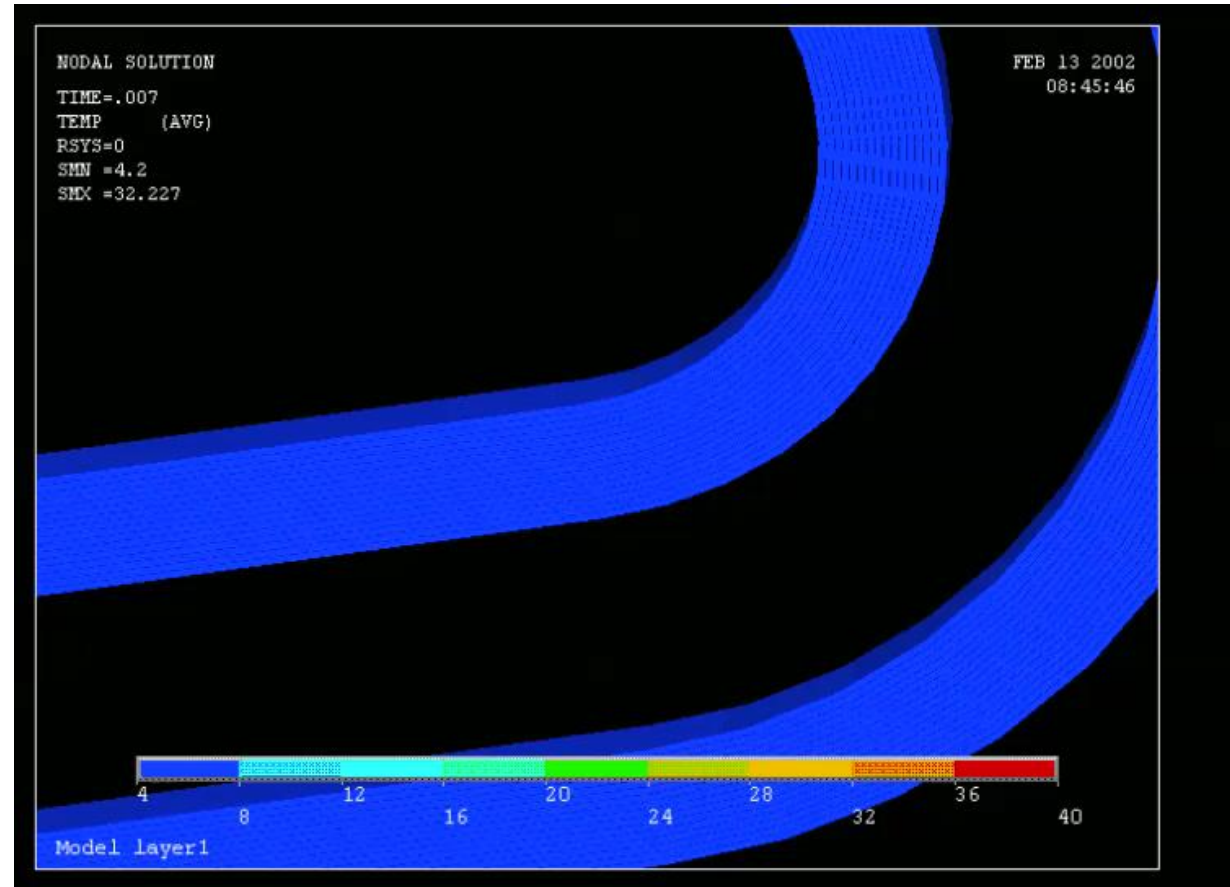

(movie)

*Courtesy: S.Caspi*

# Lumped element and “circuit” models

## LEDET method (Lumped Element Dynamic Electro-Thermal)

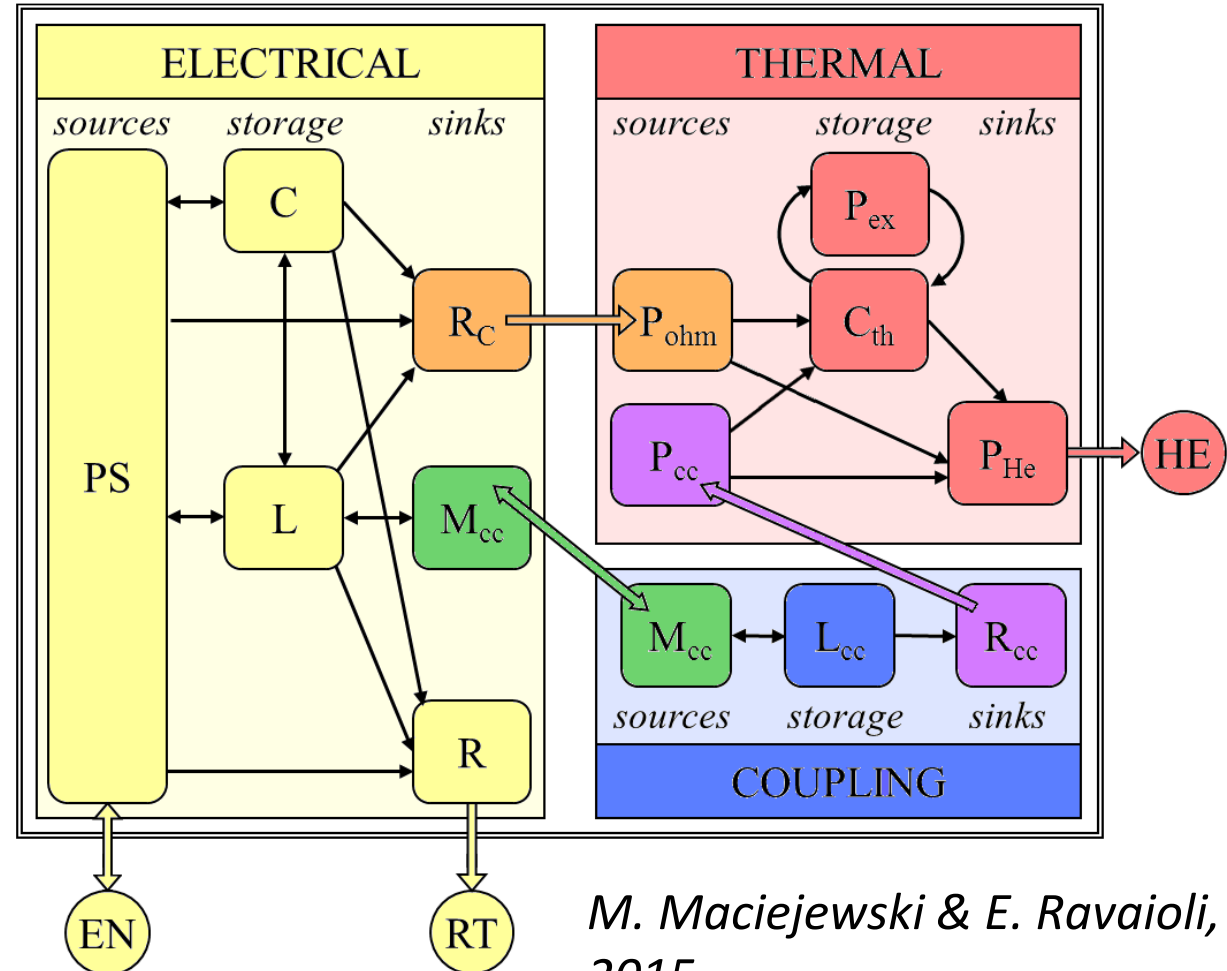
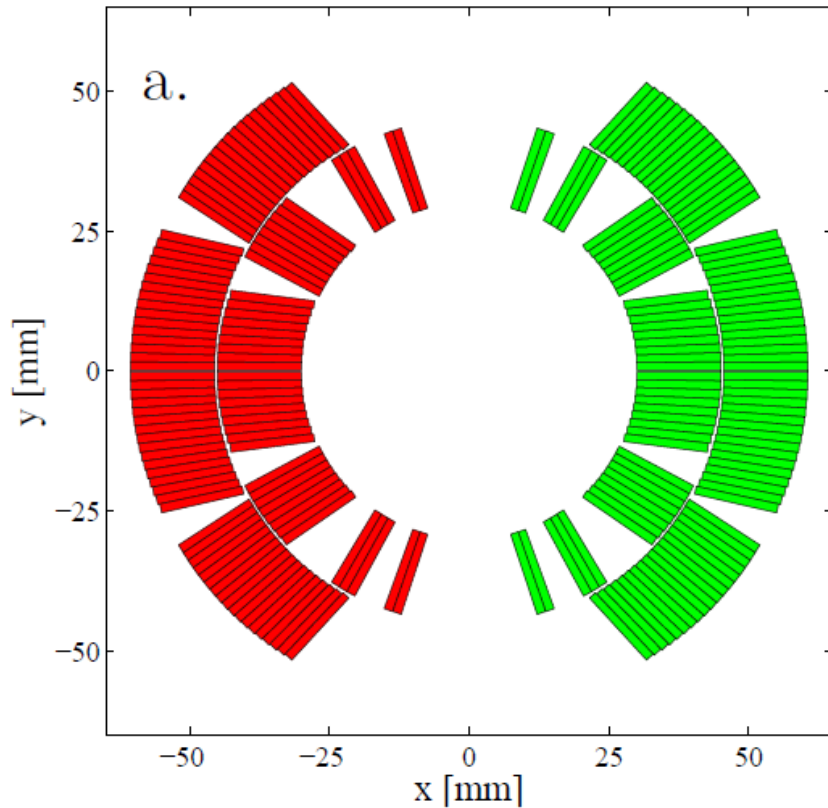

*M. Maciejewski & E. Ravaioli, 2015*

# Voltage distribution in a quenching magnet

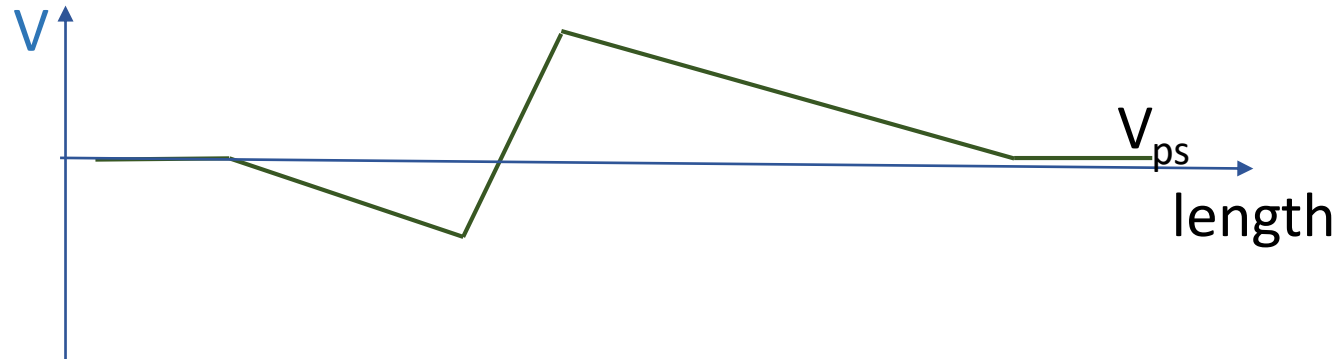

$$V_Q(t) = I(t)R_Q(t) - M \frac{dI(t)}{dt} \quad L \frac{dI(t)}{dt} \cong I(t)R_Q(t)$$

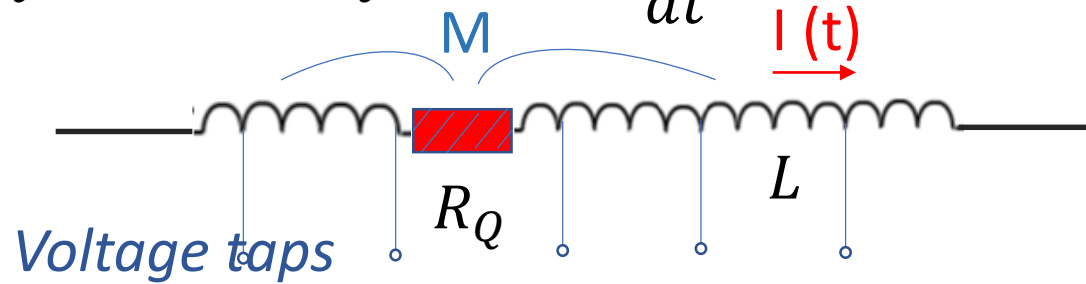

$$V_Q(t) = I(t)R_Q(t) \left(1 - \frac{M}{L}\right)$$

$$V_Q(0) = V_Q(\infty) = 0 \Rightarrow \text{peaks during the quench}$$



Voltage taps examples

**Internal magnet voltage during quench may reach several hundreds of volts!**

# Quench detection using voltage taps

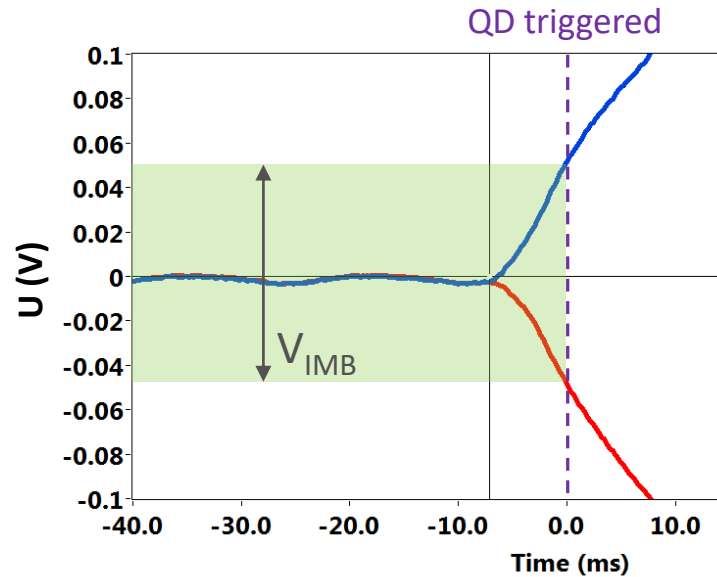
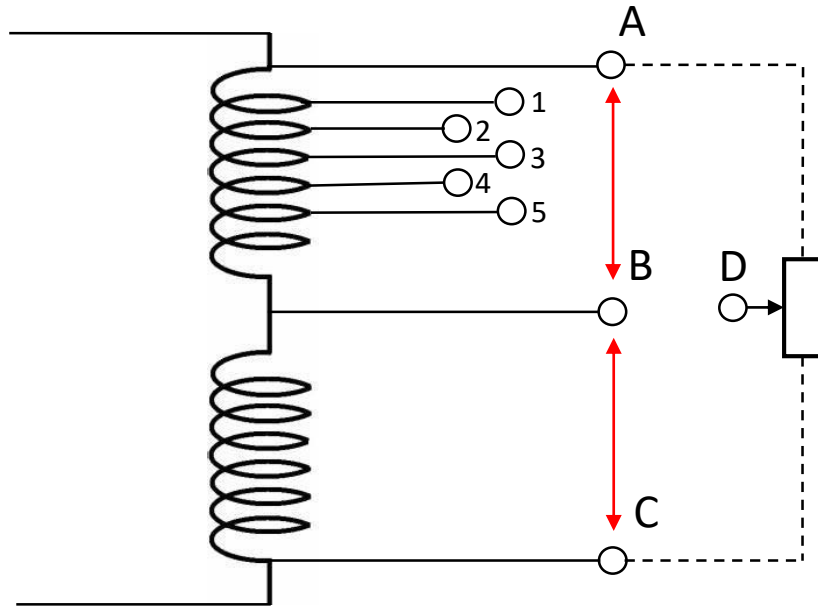

- Voltage quench detection is based on a simple set of voltage thresholds.
- For LTS magnets thresholds are typically sets at a level of 10s to 100s of mV.
- In practice, various algorithms are used to correct for inductive voltages, eliminate influence of noise spikes They also allow for a time window in which voltage should exceed the threshold to qualify as a quench (say >100 mV for more than 10 ms as in CERN QD DSP boards)

$$\left\{ \begin{array}{l} |V_{AB} - V_{BC}| < V_{IMB1} \quad - \text{Imbalance threshold (1)} \\ |V_{BD}| < V_{IMB2} \quad - \text{Imbalance threshold (2)} \\ |V_{AB} + V_{BC}| < V_{OV} \quad - \text{Over-voltage threshold} \end{array} \right.$$

A time interval over which voltage rises above the threshold is often called “detection time” ( $t_d$ ).

# Detection threshold

In  $\text{Nb}_3\text{Sn}$  magnets, it is challenging to pick a safe threshold because of flux jumps:

- Threshold may need to be adapted as current is ramped up.
- Low-pass filtering
- “Points above threshold” counter

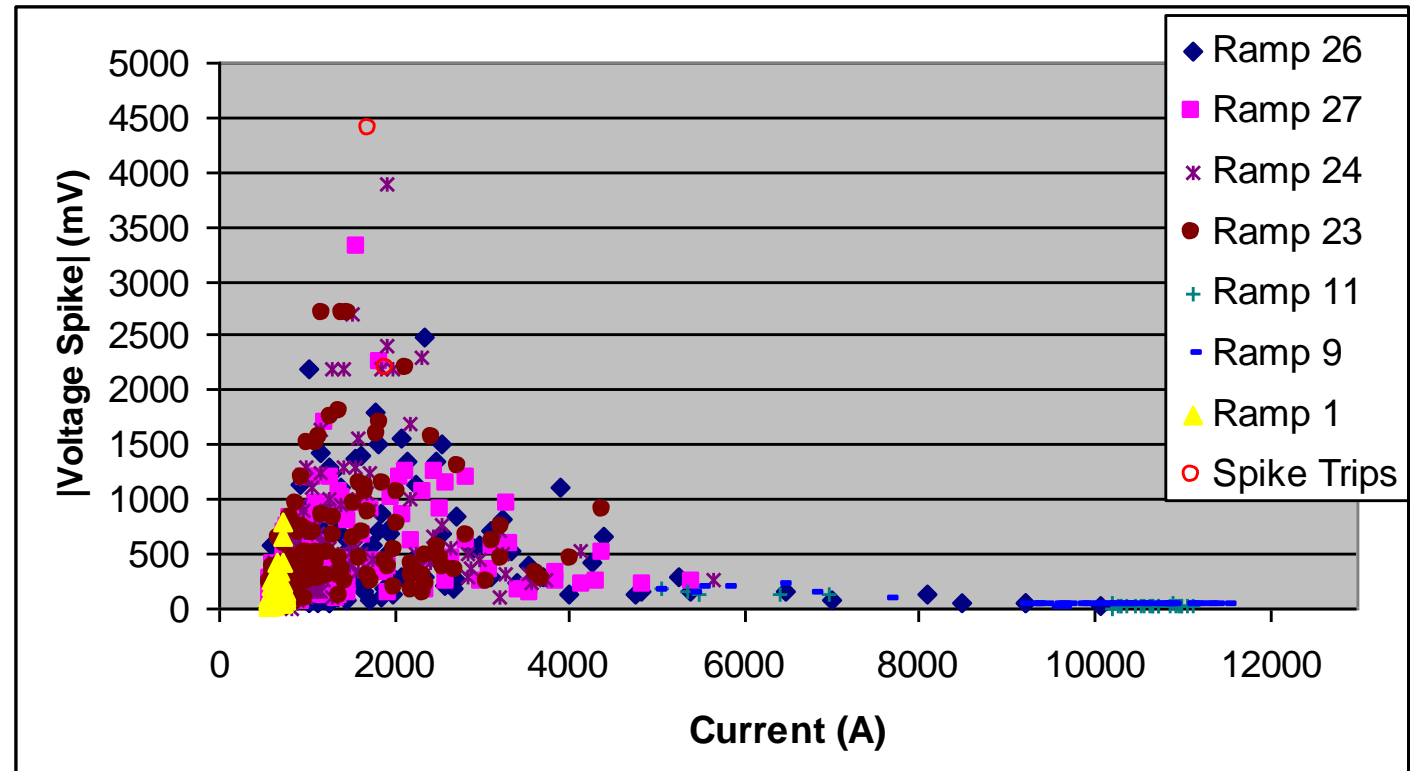

*FNAL TD-07-015 TQS02a Voltage spike analysis – C. Donnelly et al.*



# Temperature rise and hot spot temperature

Following Maddock and James (1968). Hot spot temperature can be estimated using a simple adiabatic approximation:

Heat balance of unit volume of winding:

$$J^2(t) \rho(T) dt = C(T) dT$$

*Resistivity of the stabilizer  $\Omega m$*   
*Volumetric specific heat (averaged)  $J/m^3 K$*   
*Current density,  $A/m^2$*   
*heat generation*      *windings enthalpy*

$$\int_{T_0}^{T_q} \frac{c(T)}{\rho(T)} dT = \int_0^\infty J^2 dt = \frac{1}{A^2} \int_0^\infty I^2 dt$$

*U(T)*      Cross-sectional area of the conductor      **(M)IITs**  
 "Millions of I\*I\*Time"

For the stabilized conductor with copper volume fraction  $r$  :

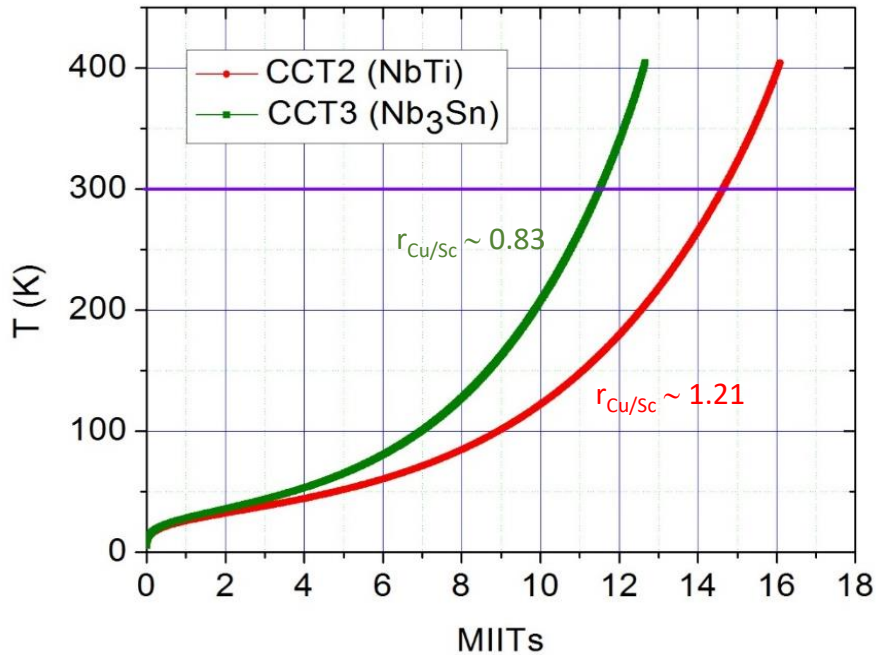

$$F(T_q) = \int_{T_0}^{T_q} \frac{C(T)}{\rho(T)} dT = \frac{1+r}{r} \int_0^\infty J^2 dt$$

Note that adiabatic  $T_q$  is independent on the size of the normal zone!

Usually,  $T_q < 350$  K is considered "safe" for epoxy-impregnated windings of experimental magnets. In accelerators  $T_q < 150-200$  K is usually sought. Higher temperatures may lead to epoxy breakdown leaving conductor unsupported under Lorentz forces, resulting in loss of magnet quench performance.

# Effect of RRR on hot spot temperature

$$RRR = \rho_{300\text{K}} / \rho_{4.2\text{K}}$$

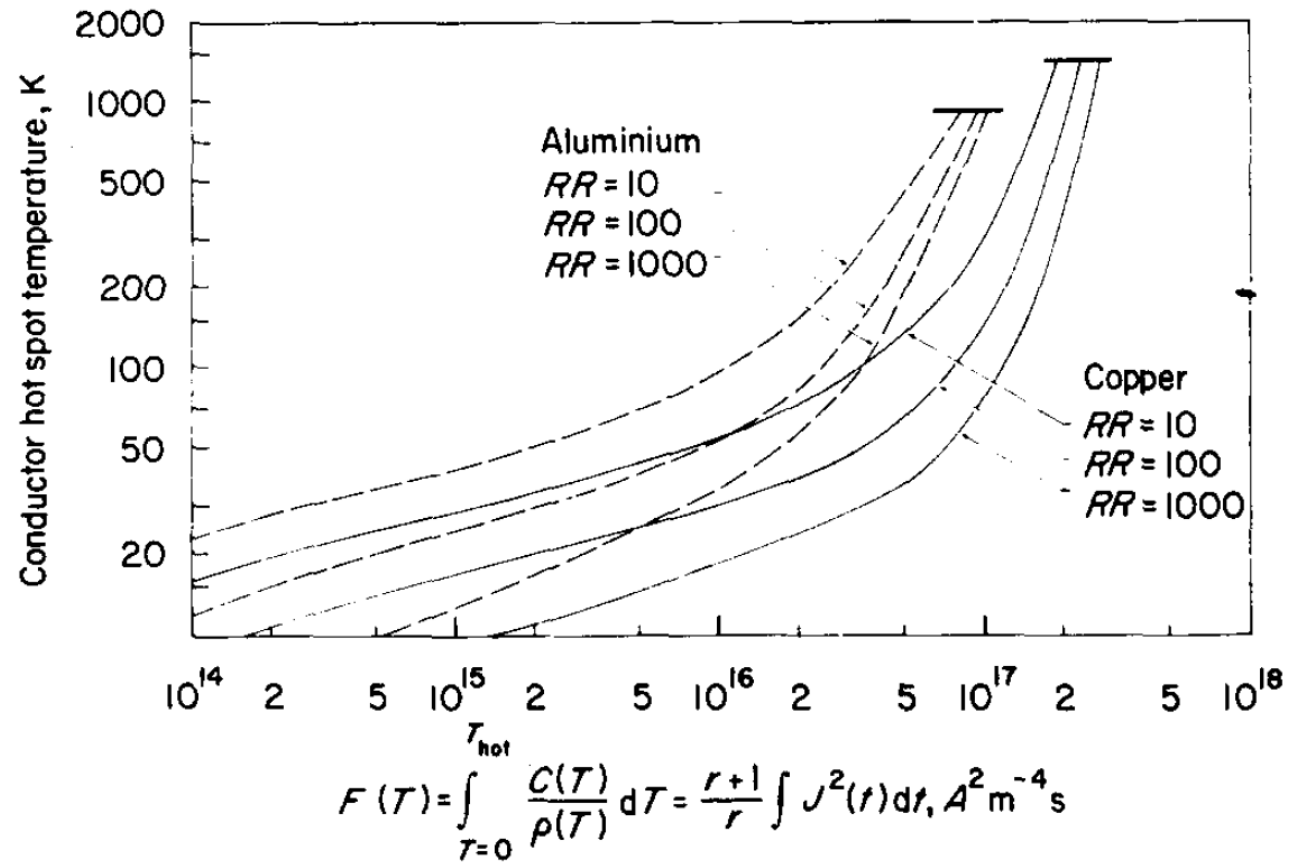
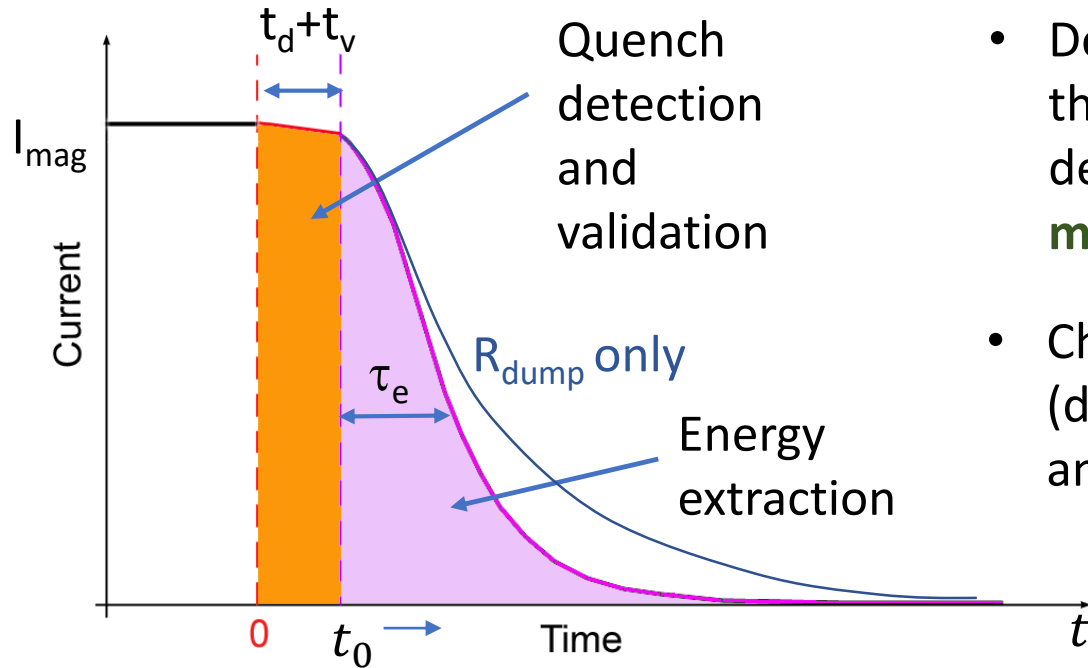

Fig. 1 Peak hot spot temperature  $T_M$  as a function of  $F(T_M)$  for various coppers and aluminiums

Cable RRR > 150-200 is typically required for high-field accelerator magnets

# Quench protection timeline and objective



- Detection time  $t_d$  depends upon sensitivity and thresholds of QDS. “Validation time”  $t_v$  is typically defined by the hardware. **Typically, for LTS accelerator magnets  $(t_d+t_v) \sim 7-15$  ms**
- Characteristic extraction time  $\tau_e$  depends upon magnet (dynamic) inductance and the sum of magnet resistance and dump resistance:

$$I(t) = I_0(t_0) e^{-t/\tau_e} = I_0 e^{\frac{-t(R_{mag}(t)+R_{dump})}{L(t)}}$$

As magnet inductance scales with magnet size,  $\tau_e$  can be reduced by increasing  $R_{dump}$  and reducing  $L(t)$  (**passive** protection), or by **increasing  $R_{mag}(t)$**  (**active** protection).

**Typically, for LTS accelerator magnets  $\tau_e \sim 50-200$  ms.**

**The goal of protection is to reduce  $\tau_e$  as low as possible, thus keeping the MIITs (and so the cable temperature  $T_q$ ) within acceptable limits.**

# Protection using a dump resistor

By adding an external resistor to in series with the quenching magnet, part of its energy can be “extracted” outside of the cryostat

Efficiency of energy extraction depends upon  $R_Q(t)/R_{dump}$ . At best ~50-60% of magnet energy is typically extracted outside of the cryostat using this method.

$$L \frac{dI(t)}{dt} = I(t)R_Q(t) + I(t)R_{dump}$$

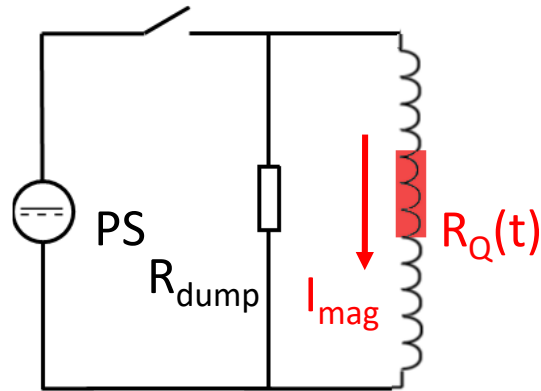

“Standard” scheme

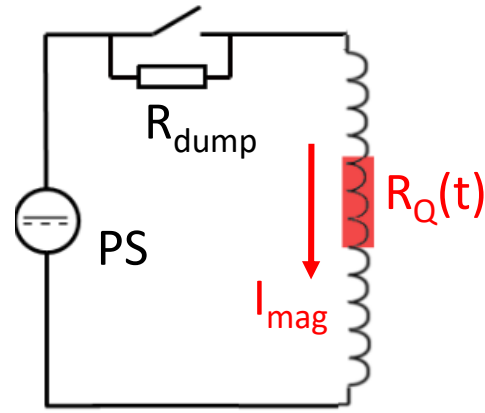

Modified schemes: ramping rate is not limited by the dump resistor

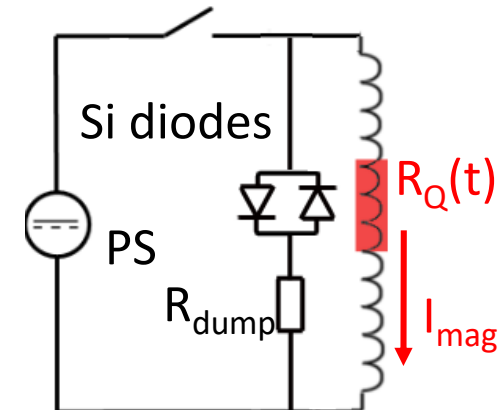

A drawback: **high voltage appears across magnet terminals**

Peak voltage:  $V_{mag\ max} = I_{mag} R_{dump}$



# High voltage as a cause of damage in quenching magnets

Typically voltages allowed in cryogenic He environment are < 1000 V (Paschen's law).

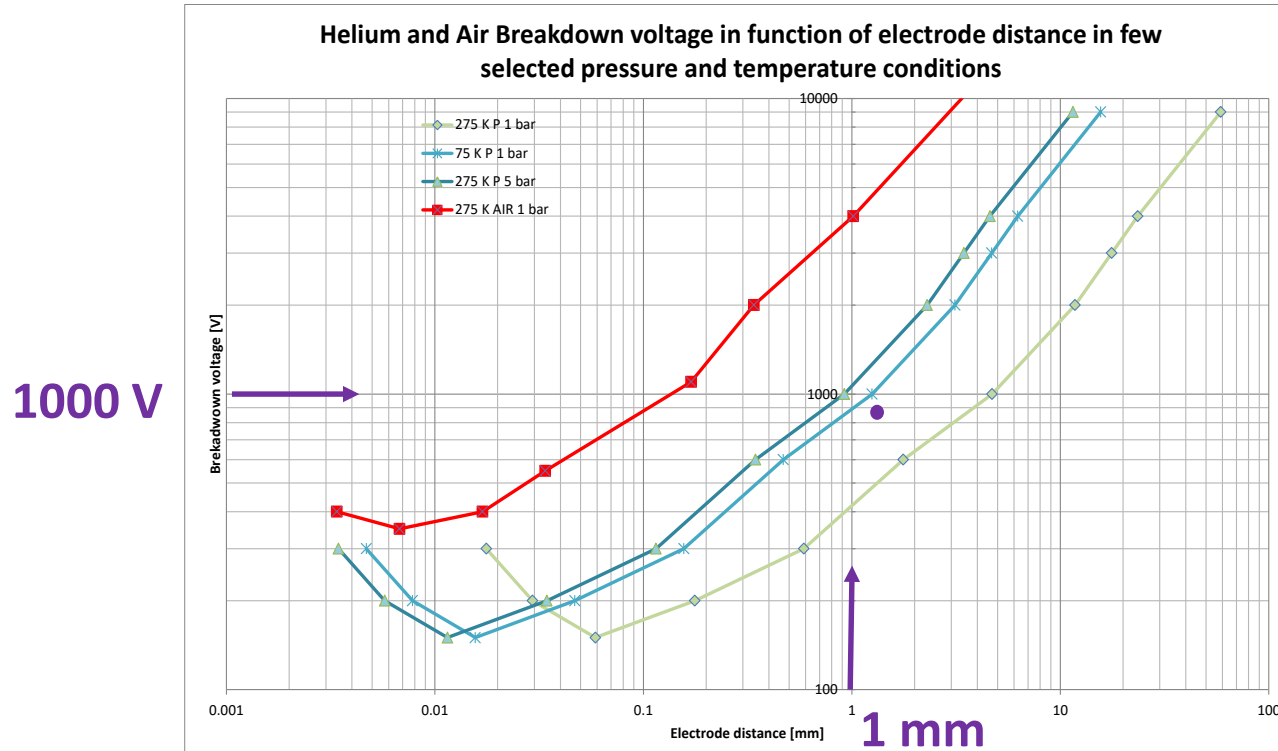

\* From P. Fessia's report on LHC electrical guidelines

Arcing (gas discharge) may start uncontrolled energy release and eventually destroy the magnet. Therefore in practice  $R_{dump}$  is limited to under  $\sim 100 \text{ m}\Omega$  in order to keep the maximal allowable magnet voltage  $V_{mag \text{ max}} = (I_{mag} R_{dump}) < 1000 \text{ V}$ .

# Inductive protection

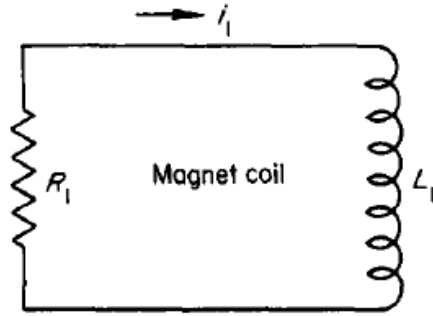

$$i = i_0 e^{-t/\tau_1} \quad \tau_1 = L_1/R_1$$

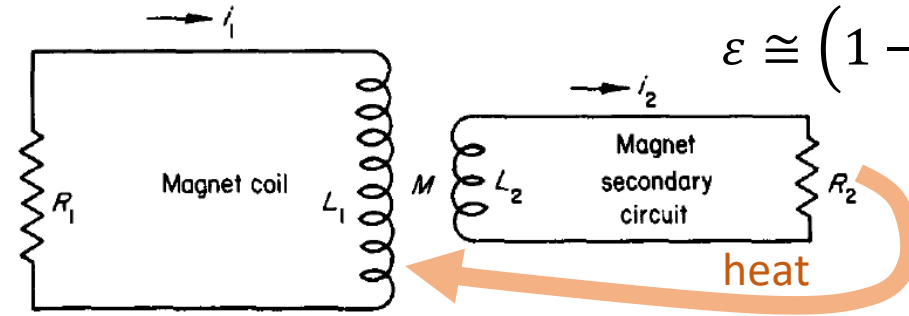

$$\varepsilon \cong \left(1 - \frac{M^2}{L_1 L_2}\right) < 0.05$$

$$i = \frac{i_0}{i_L - i_S} \left[ (\tau_1 - \tau_S) e^{-t/\tau_L} + (\tau_L - \tau_1) e^{-t/\tau_S} \right]$$

$$\tau_1 = L_1/R_1 \quad \tau_2 = L_2/R_2 \quad \tau_L \sim \tau_1 + \tau_2 \quad \tau_S \sim \frac{\varepsilon \tau_1 \tau_2}{\tau_1 + \tau_2}$$

$$F(T_M) \cong \frac{r+1}{r} j_0^2 \left(\frac{\tau_1}{2}\right)$$

>

$$F(T_M) \cong \frac{r+1}{r} j_0^2 \left[ \frac{\tau_1^2}{2(\tau_1 + \tau_2)} + \frac{\tau_S}{2} \right]$$

M. A. Green, *Cryogenics* 24, p. 659 (1984)

- A secondary LR circuit inductively coupled to the magnet coil will reduce the quench integral, removing portion of the magnet energy and dissipating it in the secondary circuit
- Heat dissipated in the outer circuit can be also supplied back to the coil to quench its superconducting fraction. This is called “quench back”; it can employed to reduce hot spot temperature and coil voltage during quench.

# Example: current decay in Nb<sub>3</sub>Sn canted cosine theta dipole

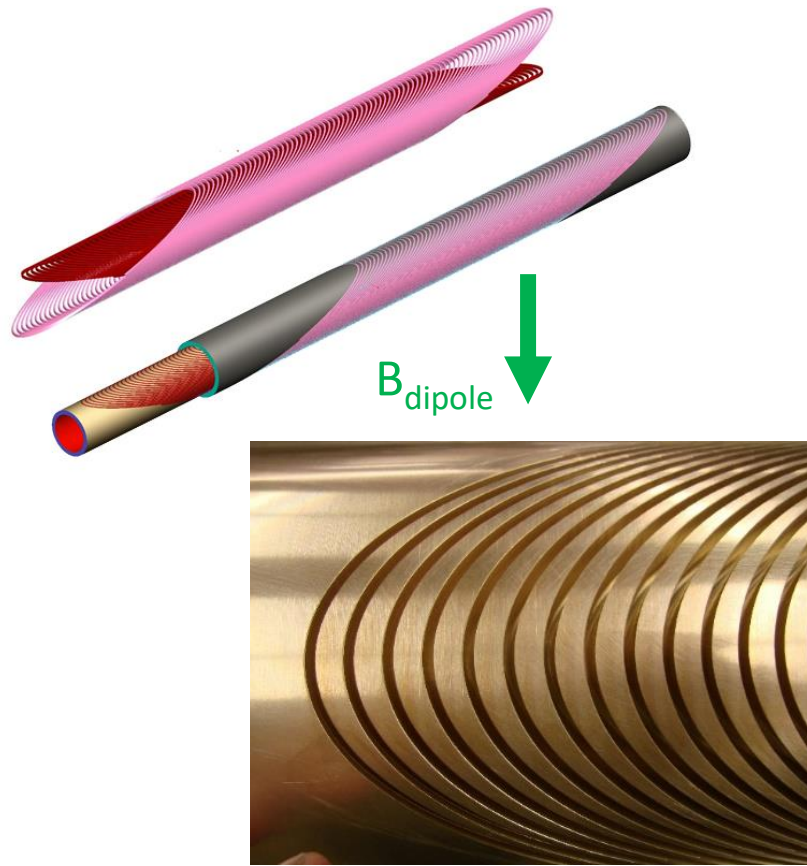

Al bronze mandrel

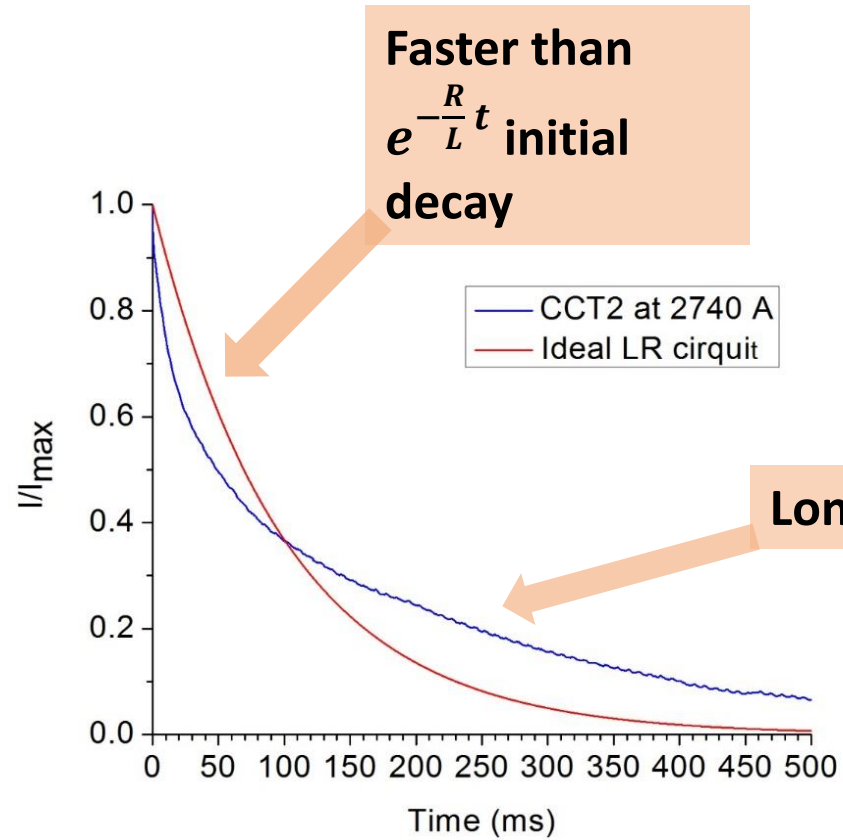

Faster than  $e^{-\frac{R}{L}t}$  initial decay

*Energy is "pumped" into eddy currents*

Long "tale"

*Eddy currents take a long time to decay*

Current decay (normalized) measured at 20 mΩ dump resistor. Calculated magnet zero-frequency inductance is 2.0 mH.

# Energy dissipation during passive protection

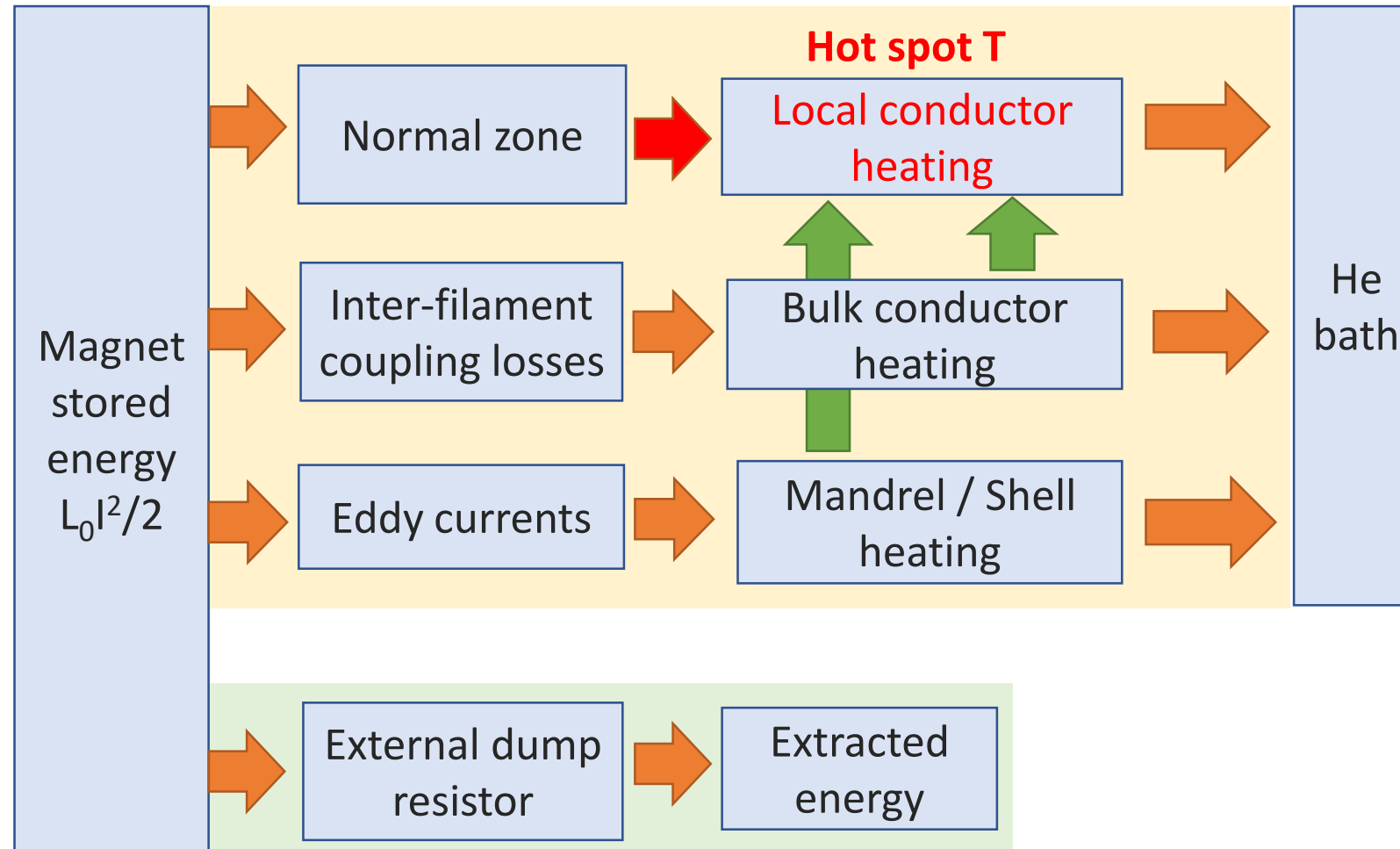



# Protection heaters

“**Protection heaters**” are thin foil strips placed (usually epoxy-impregnated) on top of the winding. Heaters are normally operated by discharging a switch (thyristor, IGBT)- controlled capacitor bank (often called “HFU” – heater firing unit). They are fired as soon as quench is detected to **spread normal zone across the magnet** (thus increasing  $R_{mag}$ ).

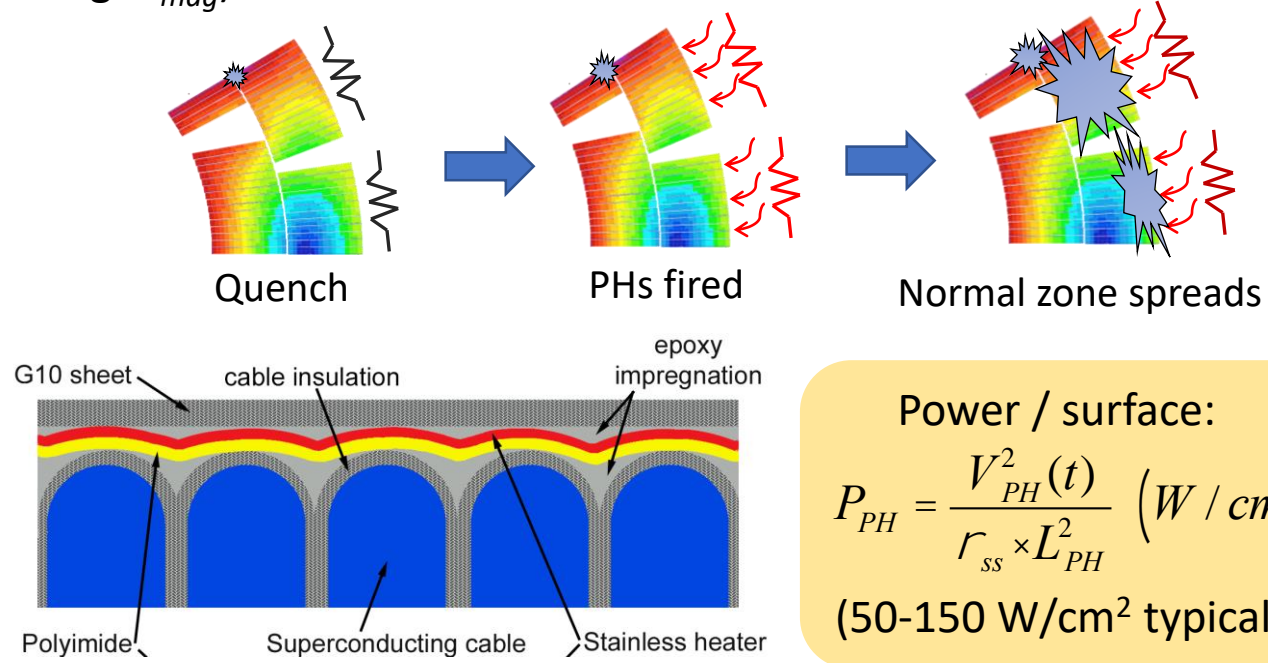

PH strip on top of the HQ-series coil

**Uniform** stainless strip covering the largest possible area of the coil winding is the simplest protection heater. It is usually fabricated on top of the 25-75 micron-thick polyimide (Kapton) layer.

- Uniform heaters strips are not suitable for long magnets, as the voltage  $V_{PH}$  required to keep the same  $P_{PH}$  grows prohibitively large ( $\sim L_{PH}$ ).

# Protection heaters with “heating stations”

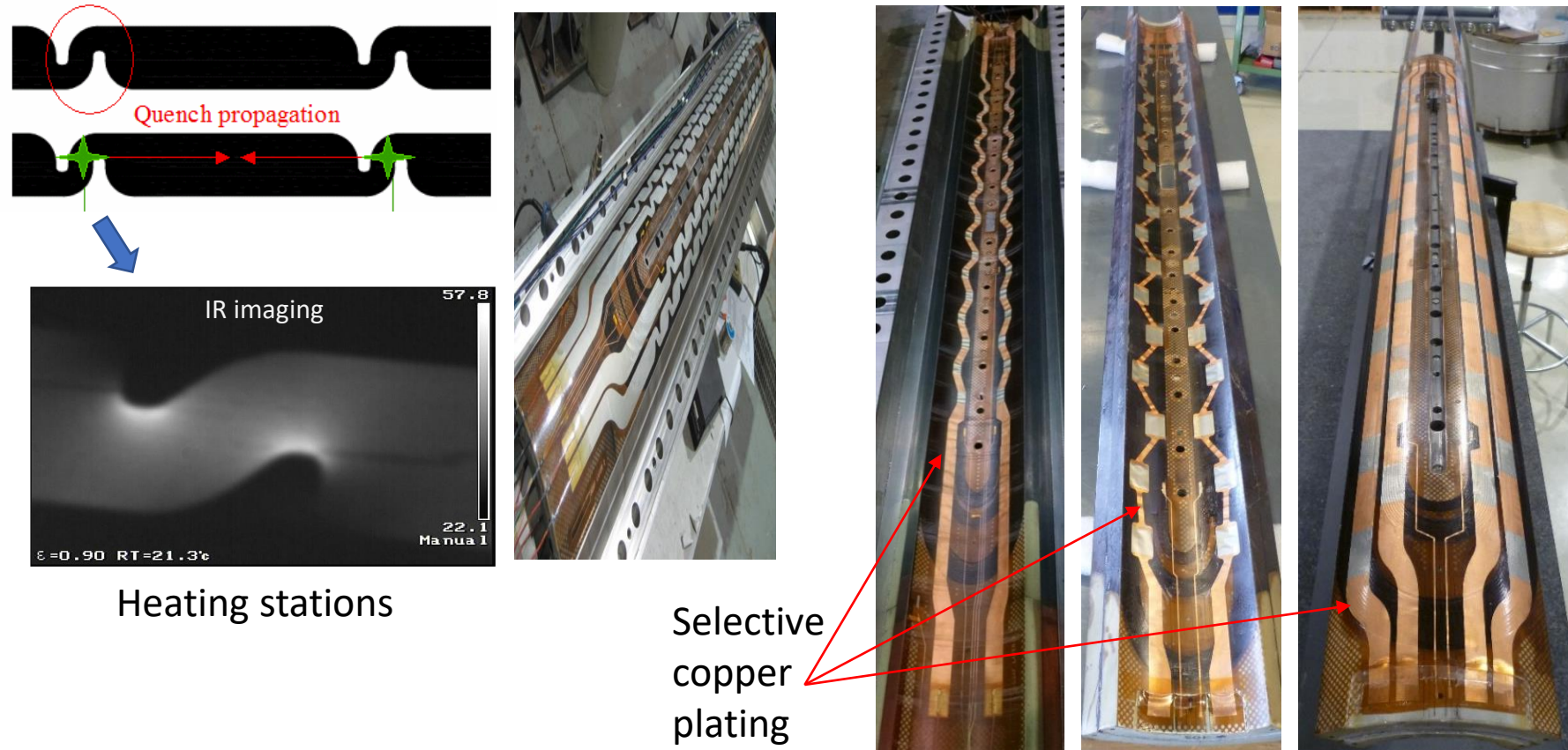

Heating stations

Selective copper plating

“Heating stations” are zones of higher resistance fabricated by means of narrowing a current path or by selective copper-plating. Such heaters can be scaled up in length, and rely on forming periodic normal zones that subsequently expand as quench propagate. Relying on quench propagation, however, slows down growth of  $R_{mag}$ , compared to uniform strip heaters of same  $P_{PH}$ .

# Protection heater delays

It takes time (typically a few milliseconds) for the heat generated by a protection heater to diffuse into the cable through the polyimide layer and cable insulation, and heat the cable strands above  $T_{CS}(B)$ . Heater delay is thus a function of heater power (limited by the max allowable temperature), net insulation thickness, and magnet current (which controls the  $T_{CS}(B)$ ).

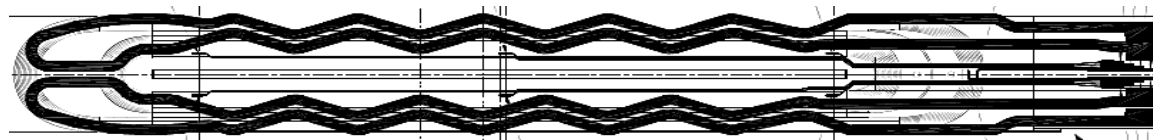
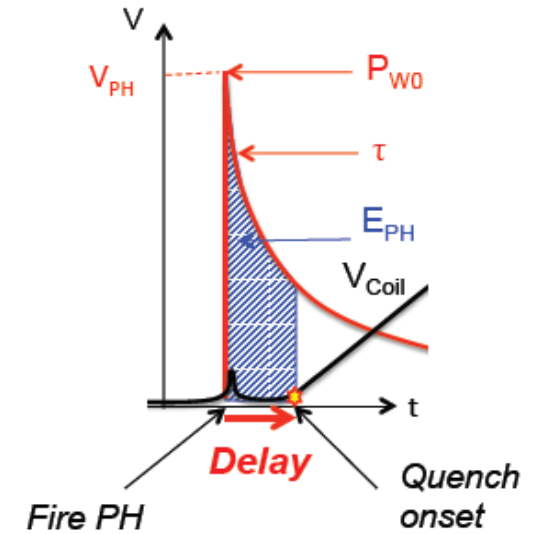

PH peak power = 50-55 W/cm<sup>2</sup>,  $\tau$  = 40-45 ms

$\tau$  = 90 ms

*T. Salmi, WAMSDO Workshop, CERN*

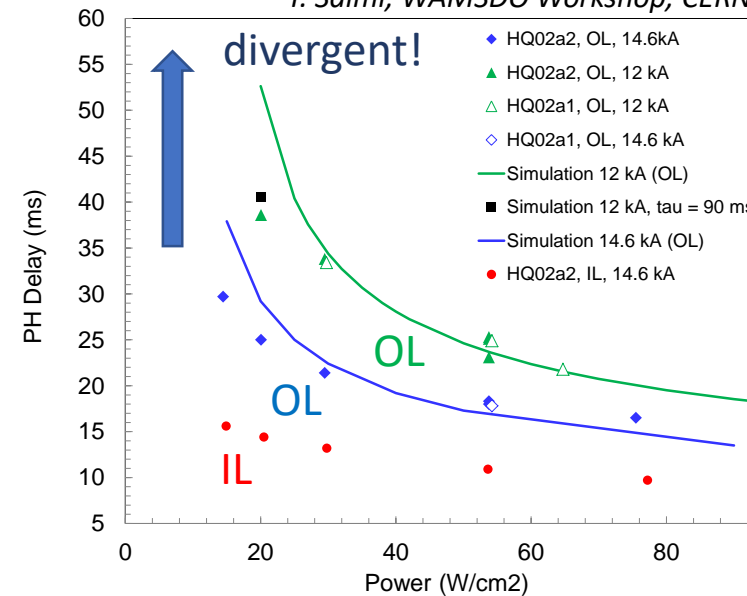
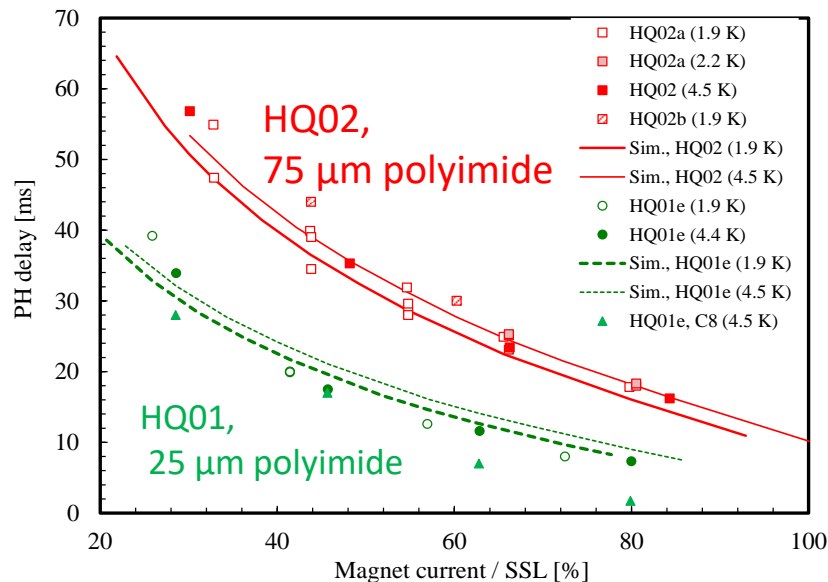

# Redundancy and optimization of PHs

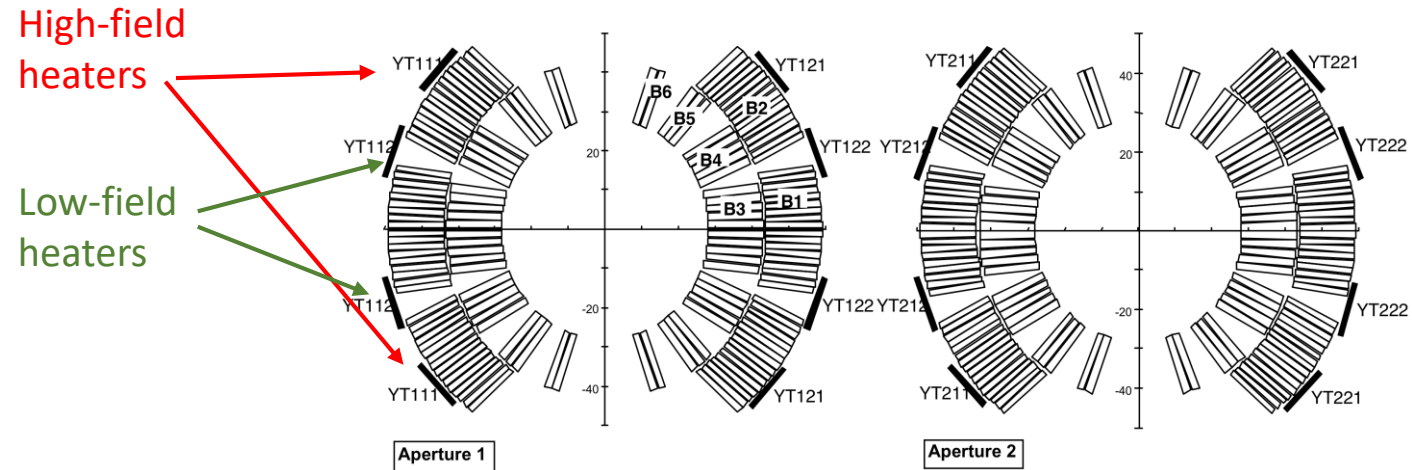

- Individual powering for redundancy, and power optimization for heater strips covering low and high-field zones.
- Optimization of a heater strip layout is required so that the heaters are effective at every current level of the magnet (low to high). A combination of various patterns can also be used
  - Short “heating stations” are less effective
  - Heated length equal to cable transposition length is desirable for low-current

Heater simulation and optimization software packages:

SPQR: DOI: 10.1016/s0011-2275(01)00008-x

QUABER: DOI: 10.1109/20.119887

CoHDA (Tampere University of Technology): DOI: 10.1109/TASC.2014.2311402

# Some drawbacks of PHs

PHs while widely used have some drawbacks:

- Delamination (bubbles form), especially when heater is placed on unsupported (IL) surface of the coil
- Electrical breakdowns
- Poor performance at low magnet currents



*Non detected failure of a QH. As seen after dismounting during inspection of the QH.*



*Thermal imaging of delaminated PH strips* →

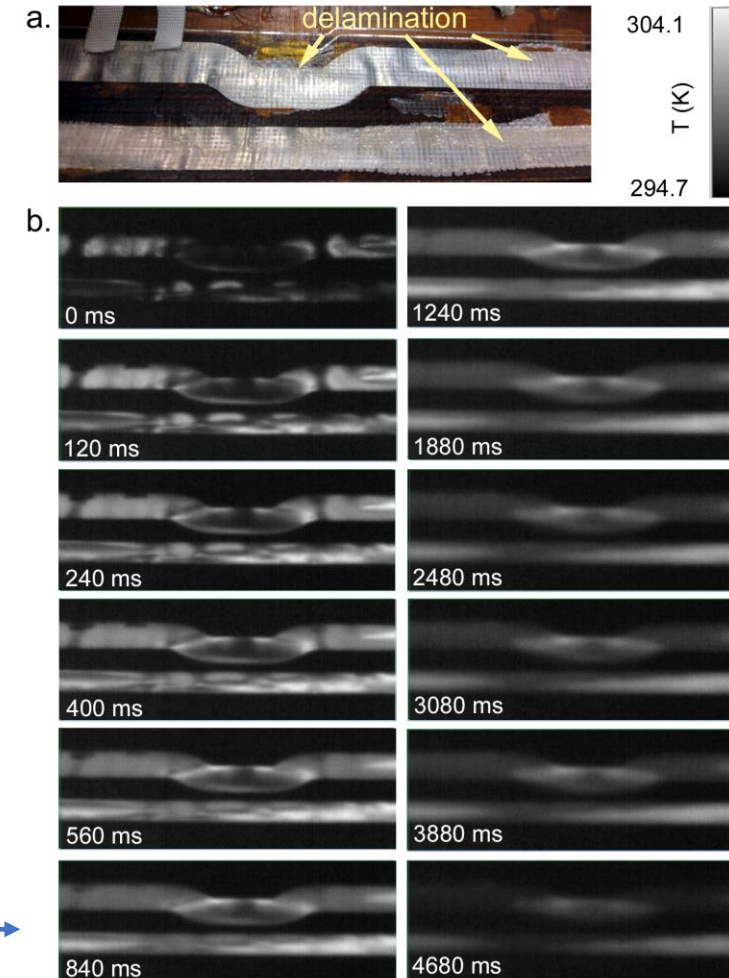

**Protection heaters rely upon on thermal diffusion across insulation, and may be intrinsically too slow for protecting some types magnets...**

# Bulk heating of the conductor with ac losses

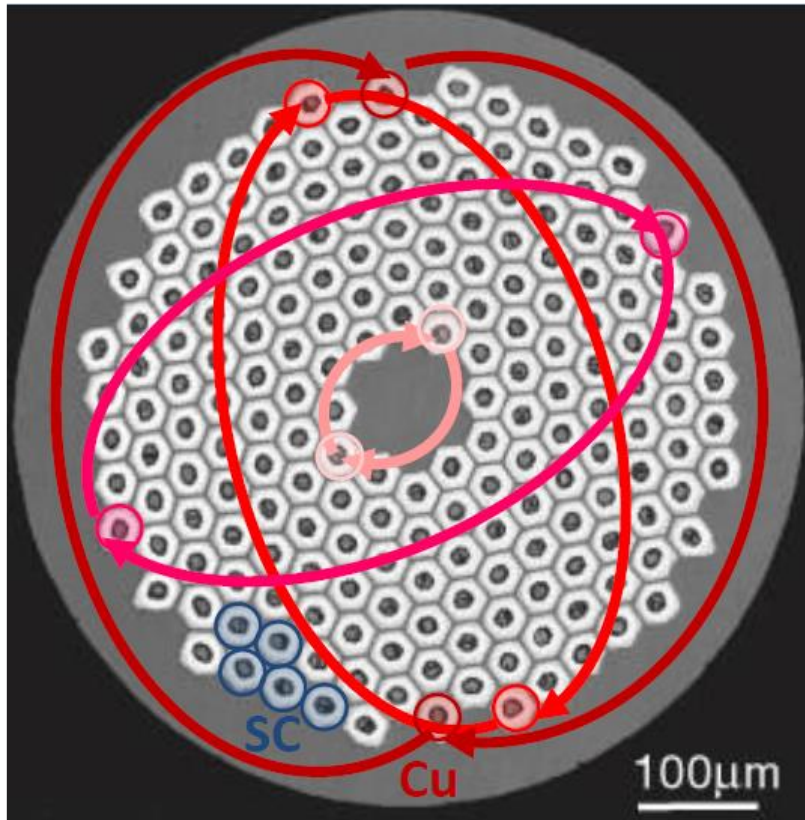

Inter-filament “coupling loss”

$$P_{if} = \left( \frac{l_f}{2\pi} \right)^2 \frac{1}{\rho_{eff}} \left( \frac{dB_t}{dt} \right)^2$$

- When current in the magnet is varied, ac magnetic field induces currents in the (resistive!) copper matrix between the superconducting filaments.
- These currents heat up the conductor interior, thus depositing heat in the bulk rather than at the surface
- The “time constant” of the **inter-filament currents** (determined by the stray inter-filament inductance and matrix resistivity,  $\tau_{if} = \frac{\mu_0}{2} \left( \frac{l_f}{2\pi} \right)^2 \frac{1}{\rho_{eff}}$ , is typically 10-20 ms for LTS strands, which is ideal for quench protection purposes.
- Other types of ac loss are inter-strand (much larger time constant) and hysteretic loss (frequency-independent, but smaller magnitude). The latter may be useful for future HTS magnet protection.

# Using $dB/dt$ for quench protection

- In fact, we always get some  $dB/dt$  when during energy extraction (whether due to  $R_{\text{dump}}$ , magnet resistance or both).
- If this field variation turns out to be sufficient for heating the conductor above  $T_{\text{cs}}$ , quench will spread in the magnet windings (thus accelerating current decay and increasing  $dB/dt$  even further...).
- This phenomenon is often observed in high-field accelerator magnets and in fact same “quench back” as we discussed earlier (except that we are dealing with inter-filament coupling currents rather than a secondary coil).

However, one can initiate ac loss in the magnet (and drive it into a quenched state) during energy extraction in a much more efficient way. It is done using a novel\* technique called CLIQ.

\* First ideas on inducing ac current in the magnet for quench protection were presented in: “QUENCH PROTECTION FOR A 2-MJ MAGNET”, J.A. Taylor et. al., Applied Superconductivity, Pittsburg, PA, September 25-28, 1978 <http://escholarship.org/uc/item/41f3s8sz>

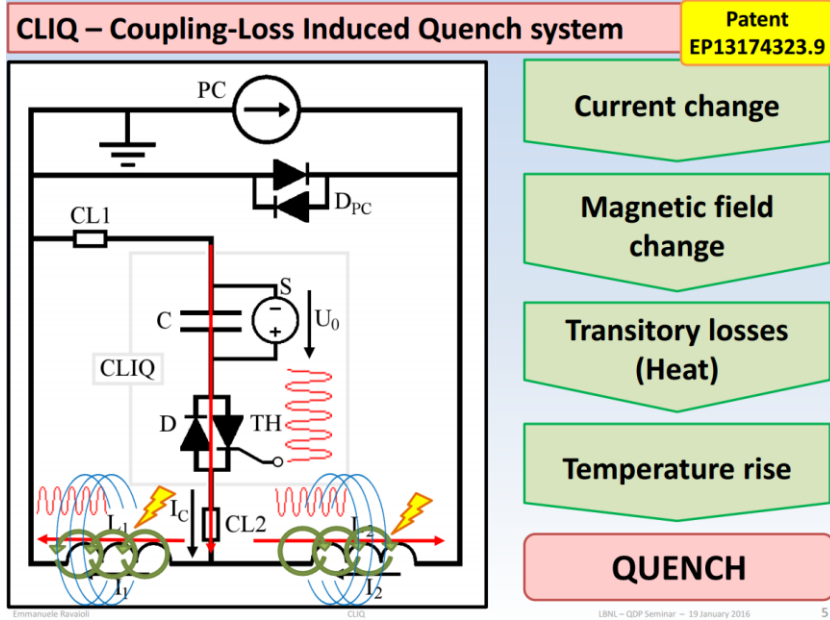

E. Ravaioli et al., *Supercond. Sci. Technol.* 27, No. 4, 044023, (2014).

- CLIQ operates by discharging a capacitor bank directly into the windings upon detecting a quench.
- An LCR circuit formed in that way oscillates at its resonant frequency (typically 20-50 Hz), inducing inter-filament losses ac in a winding that are sufficient to quench its volume at once.
- Connecting capacitor bank to the central portion of the winding reduces effective inductance, making CLIQ more effective and adaptable to various magnet configurations

CLIQ effectiveness  $\psi$  is a function of:

- Coil geometry
- Position of CLIQ connections
- Conductor parameters
- Etc...

At high current

- Low energy needed to start the quench
- High energy density, needs to be quick!

$$\frac{P_{IF}}{vol} \sim \psi^2 \frac{U_0^2}{l_m}$$

**POWER** is the key parameter

At low current

- High energy needed to start the quench
- Low energy density, velocity not critical

$$\frac{E_{CLIQ}}{vol} \sim \frac{CU_0^2}{l_m}$$

**ENERGY** is the key parameter



# CLIQ effectiveness optimization

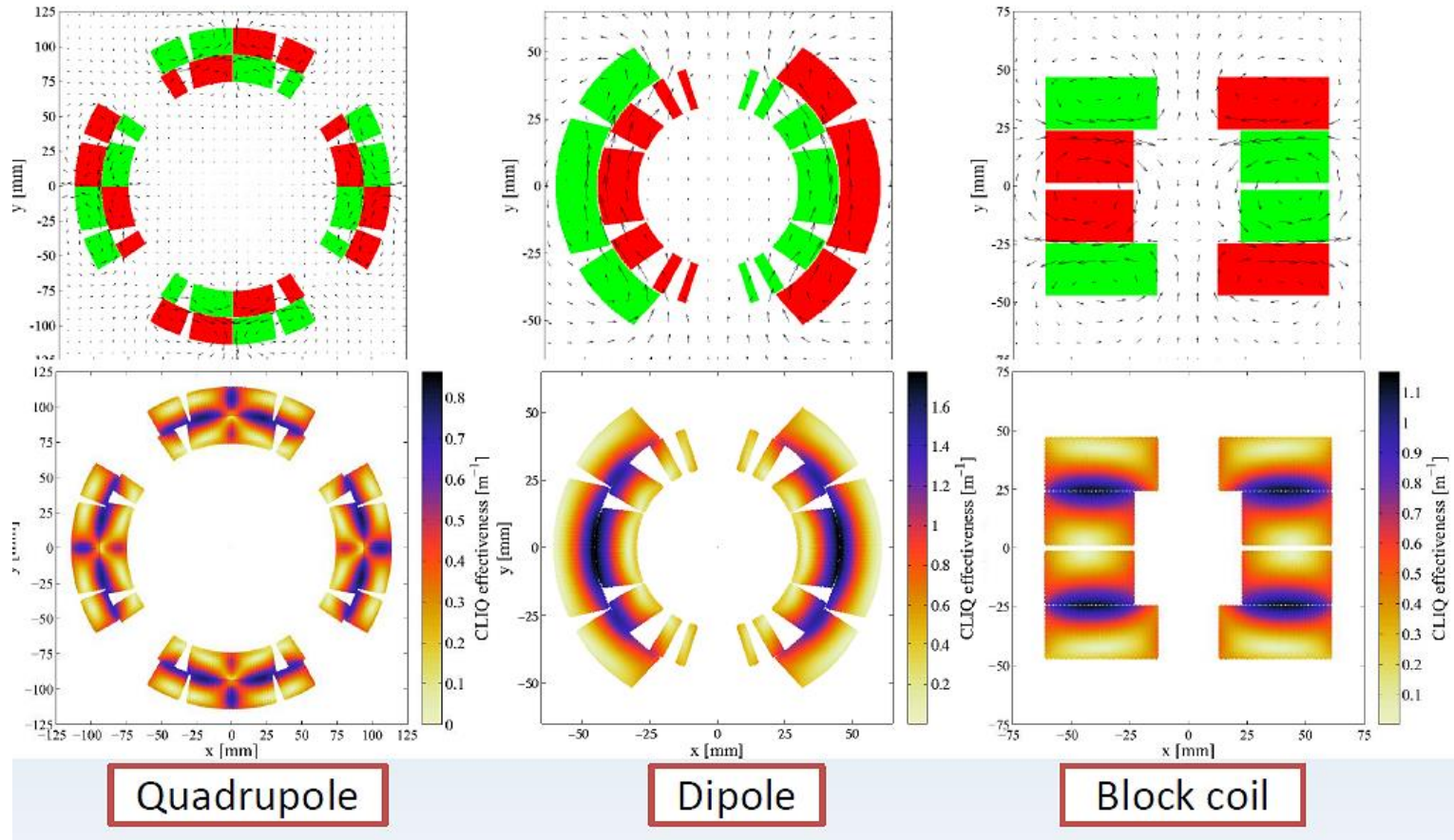

By sub-dividing coil electrically, and introducing opposite current changes in physically-adjacent sections, CLIQ effectiveness can be further improved

Con: **requires additional “CLIQ leads”**.

*E. Ravaoli, PhD Thesis, 2015*

# Hybrid protection (PHs + CLIQ)

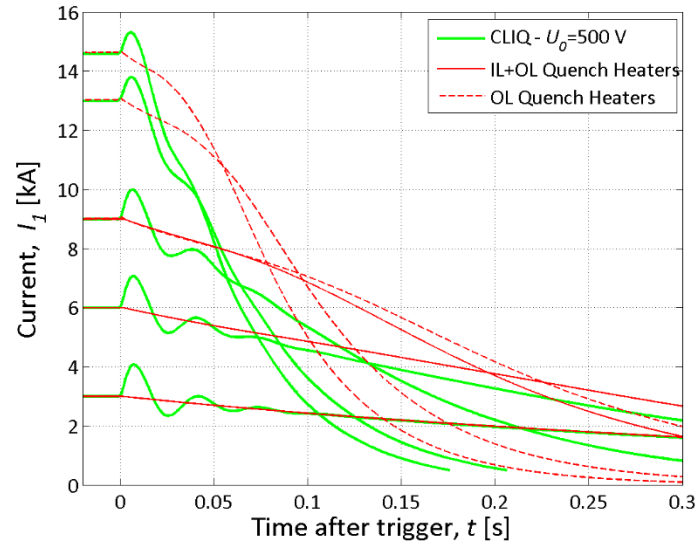

Example of CLIQ and heater studies on HQ02 high-field Nb<sub>3</sub>Sn quadrupole. Clearly, using CLIQ the current decay is substantially shortened, yielding as much as 100 K difference in the hot-spot temperature.

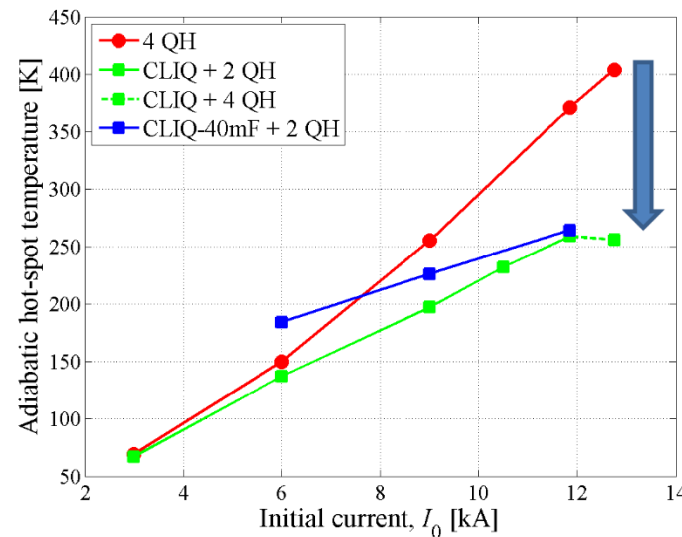
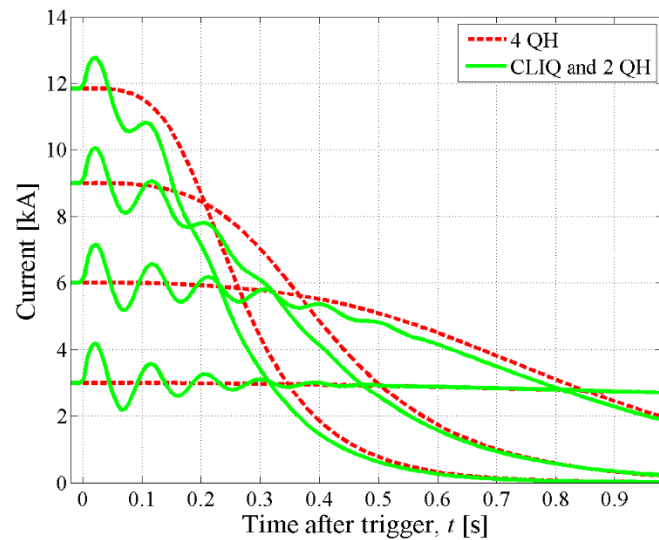

CLIQ test on a full-scale LHC dipole  
E. Ravaoli

# Protection of a chain of magnets

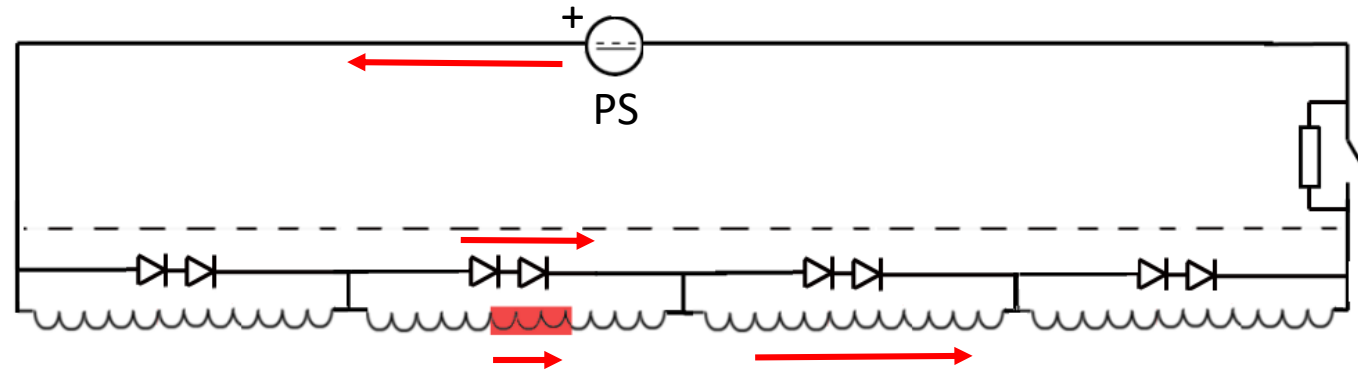

- Strings of silicon diodes are added in parallel to each magnet. Diodes start to conduct at  $\sim 2\text{-}5$  V of bias at liquid helium temperature, and therefore are not carrying any current during ramping or normal magnet operation.
- As quench occurs, voltage across the magnet rises above that level, its diodes become conductive and so the chain current is bypassed through them
- This decouples the magnet energy and rundown time from the string energy and rundown time, reducing heat dissipation
- Same scheme can be used for protection of multi-coil magnets (quadrupoles, sextupoles). A complete accelerator can be also split in several chains, depending on its size.



A Powerex R7HC1216xx Diode  
rated at 1600 A

# Chain of magnets with active protection

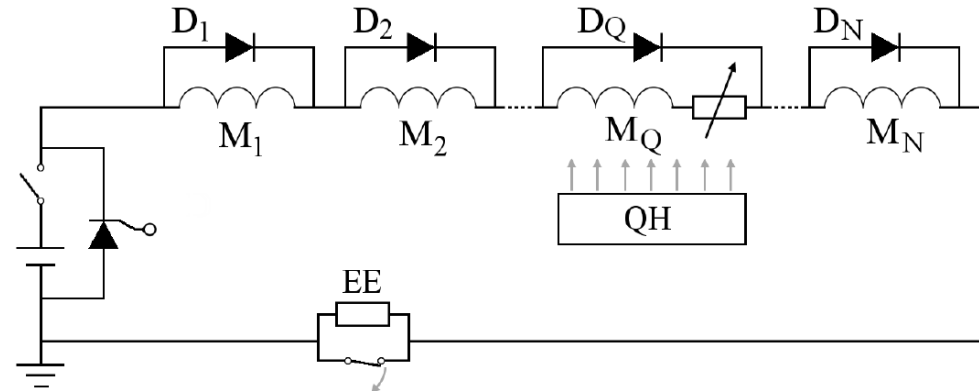

Electrical scheme of a chain of NM superconducting magnets ( $M_1$ - $M_N$ ) protected by active quench heaters (QH), by-pass diodes ( $D_1$ - $D_N$ ), and an energy-extraction system (EE). In this example, only the active protection system of magnet  $M_Q$  is activated.

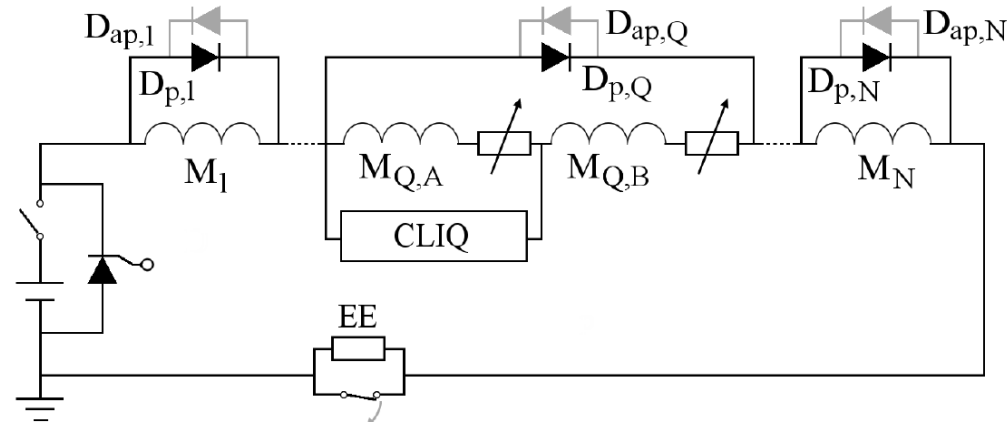

Schematic of a chain of NM superconducting magnets ( $M_1$ - $M_N$ ) protected by CLIQ, by-pass diodes in parallel ( $D_{p,1}$ - $D_{p,N}$ ) and antiparallel ( $D_{ap,1}$ - $D_{ap,N}$ ), and an energy-extraction system (EE). Only the CLIQ system connected to magnet  $M_Q$  is shown.

*E. Ravaioli, PhD Thesis, 2015*

# Quench protection at LBNL test facility

- FPGA-based quench detection system
  - 2  $\mu$ s response time (with internal 40MHz clock)
  - Programmable signal recognition capability
  - Flux jump identification and counting
  - Data 1 MSPS four channels data logging
  - Programmable digital delay line for extraction
  - Programmable heater firing sequencer
  - Inductive voltage automatic compensation



- Energy extraction system

### 4xN5946FC220 SCRs

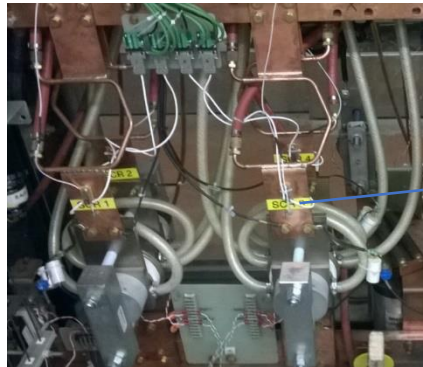

- 6000A @ 55C each
- Max voltage 1800V
- Min extraction time 1 ms

### Dump Resistor

- Adjustable: 20,24,30,40,60, or 120 m $\Omega$

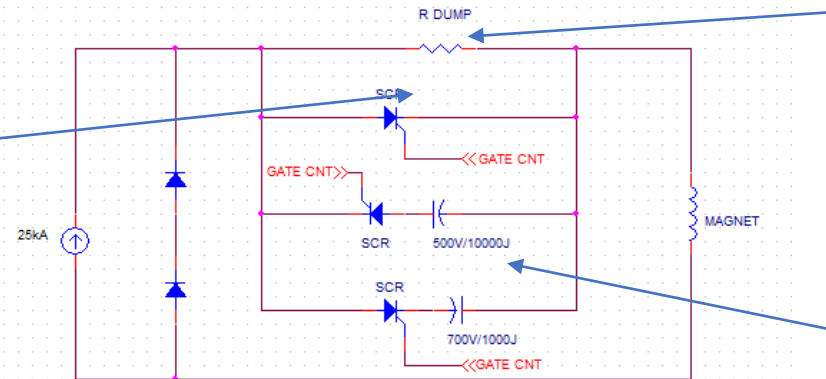

M. Turqueti

### Capacitor Bank



# References for further reading

- **M. N. Wilson “Superconducting magnets”, Oxford Science Pub. 1983**
- **K.-H. Mess, P. Schmuser, S. Wolf, “Superconducting Accelerator Magnets”, World Scientific, 1996**
- Y. Iwasa, “Case Studies in Superconducting Magnets”, Springer 2009
- A. Devred, “Quench origins” <https://lss.fnal.gov/archive/other/ssc/sscl-255.pdf>
- A. Devred, General Formulas for the adiabatic propagation velocity of the normal zone, IEEE Trans on Magnetics, Vol. 25, No. 2, March 1989
- Lectures on Superconducting Magnet Test Stands, Magnet Protections and Diagnostics:  
<https://indico.cern.ch/event/1281454/contributions/>

# Inductive quench antennas

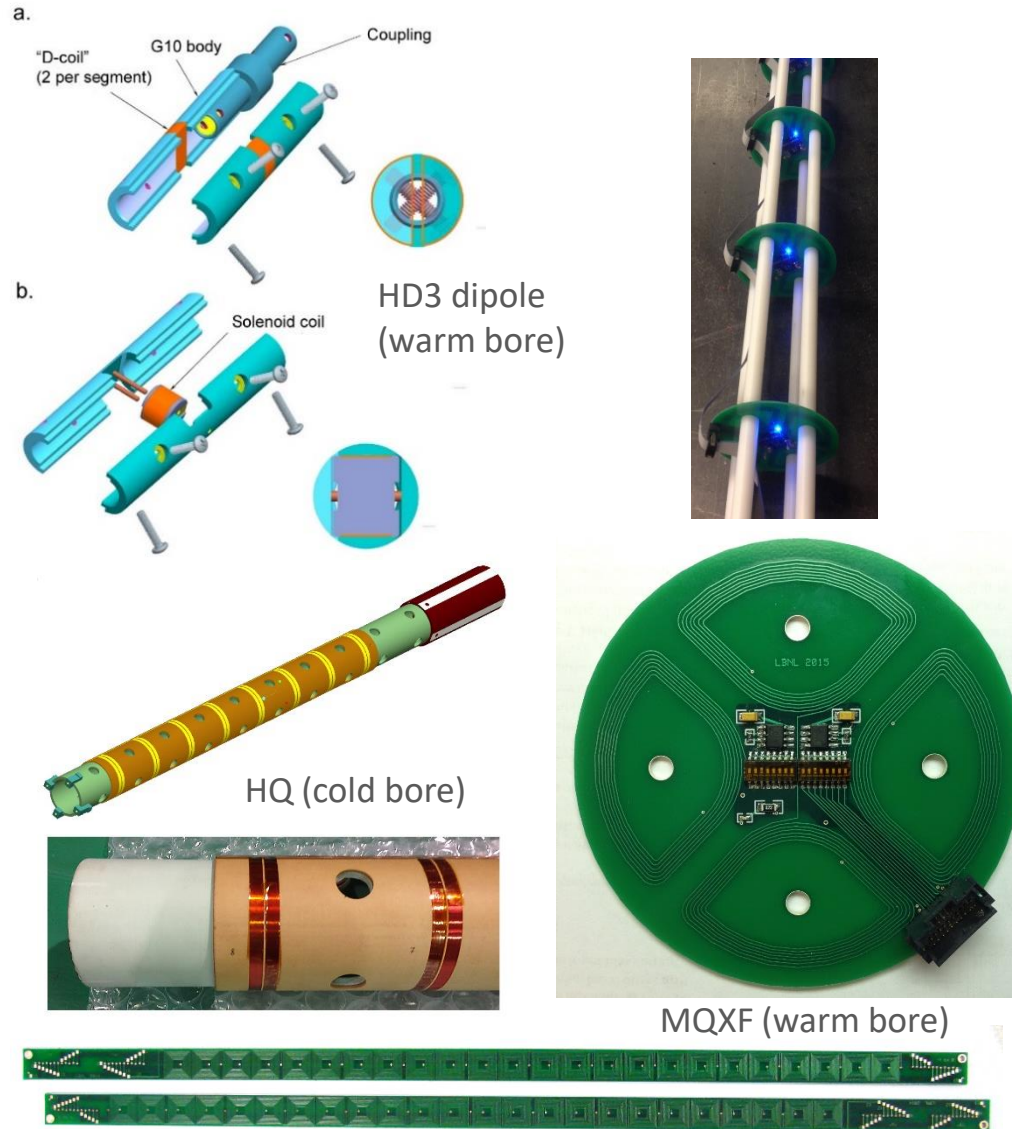

Inductive pickup coils detecting re-distribution of current in the quenching cable allowing to localize quenches and understand their origins.

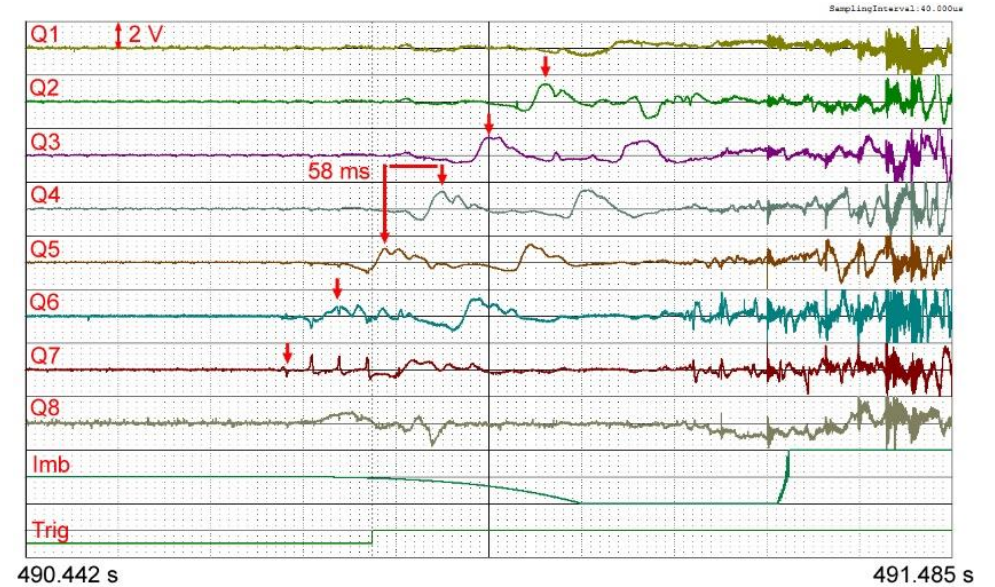

Development and propagation of a slow quench in HQ02b at 6 kA recorded by the quench antenna

# Acoustic emission sensors

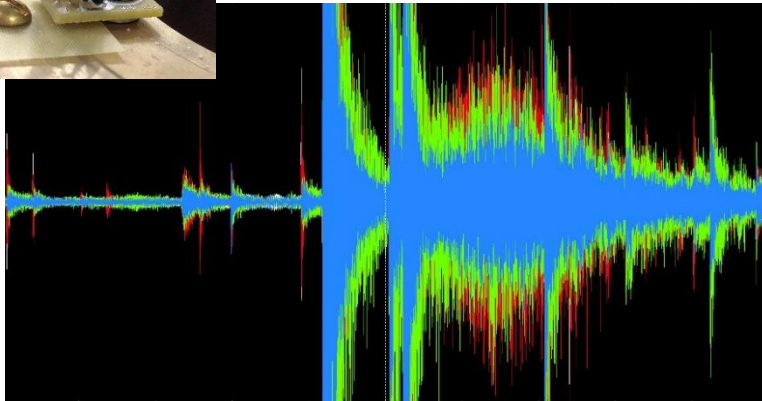
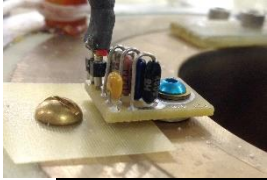

- Acoustic emission detection/triangulation system uses arrays of piezoelectric sensors to detect mechanical events / quench precursors in the magnet and localize quenches using the triangulation technique.

## Axial localization

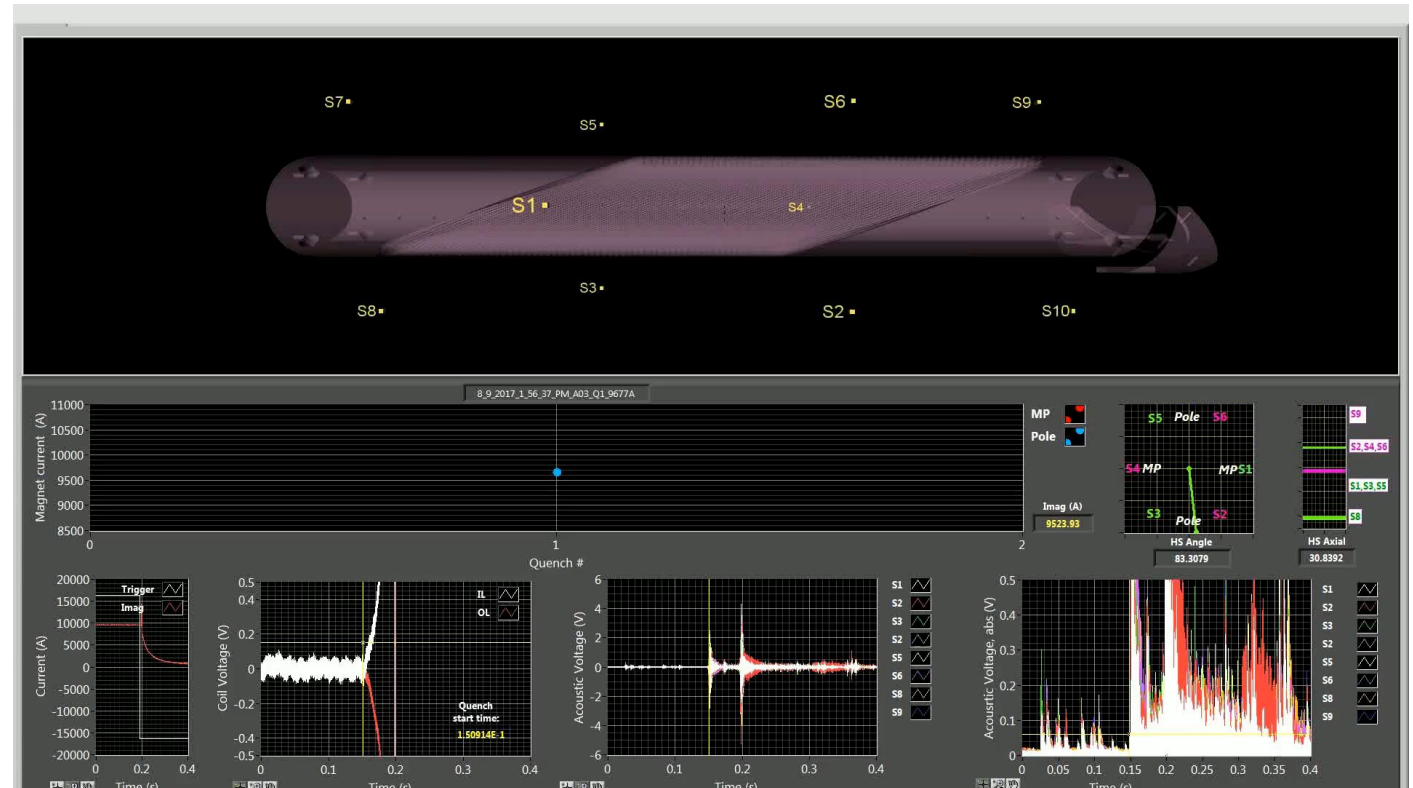
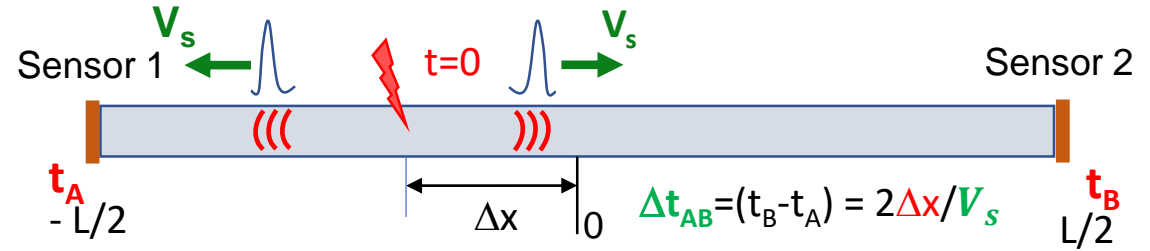



# Capacitive quench detection technique

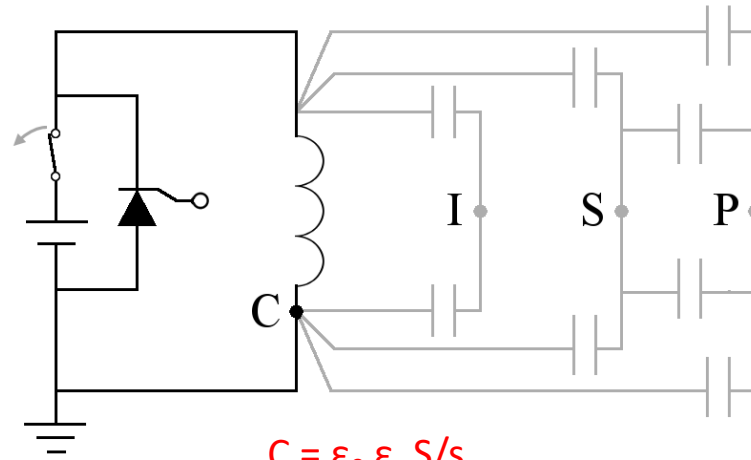
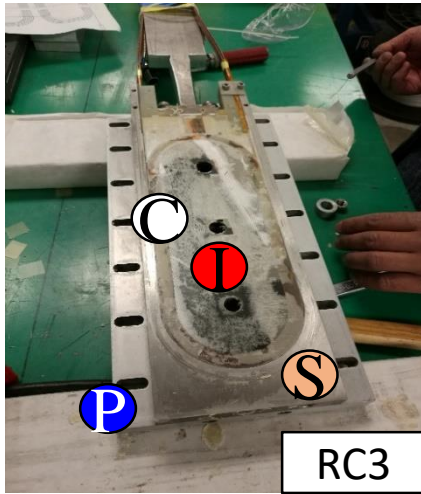

$$C = \epsilon_0 \epsilon_r \frac{S}{s}$$

$\epsilon_0 = 8.854 \cdot 10^{-12} \text{ Fm}^{-1}$   
 $\epsilon_r$  rel permittivity  
 $S$  contact surface  
 $s$  distance

Stray capacitance can be measured between any metallic component electrically insulated from the others

The mechanism leading to stray capacitance change just before quench is the decrease of cryogen fluid's electrical permittivity  $\epsilon_r$  when the phase change occurs.

This happens when the fluid impregnating the insulation boils off.

*"Quench Detection Utilizing Stray Capacitances", E. Ravaioli, et al., IEEE Trans. Appl. Supercond. 28, 4702805 (2018)*

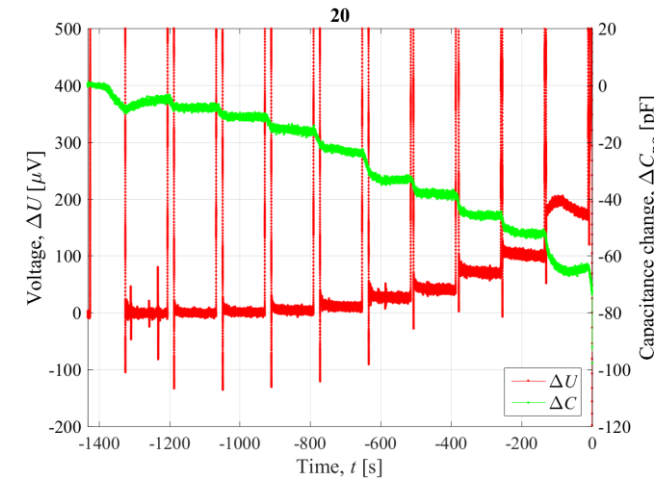
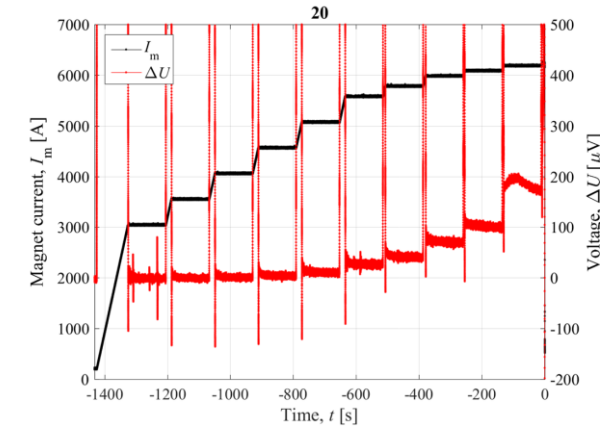

Measured magnet voltage does not include voltage drop across the splices

- Rayleigh scattering-based sensors

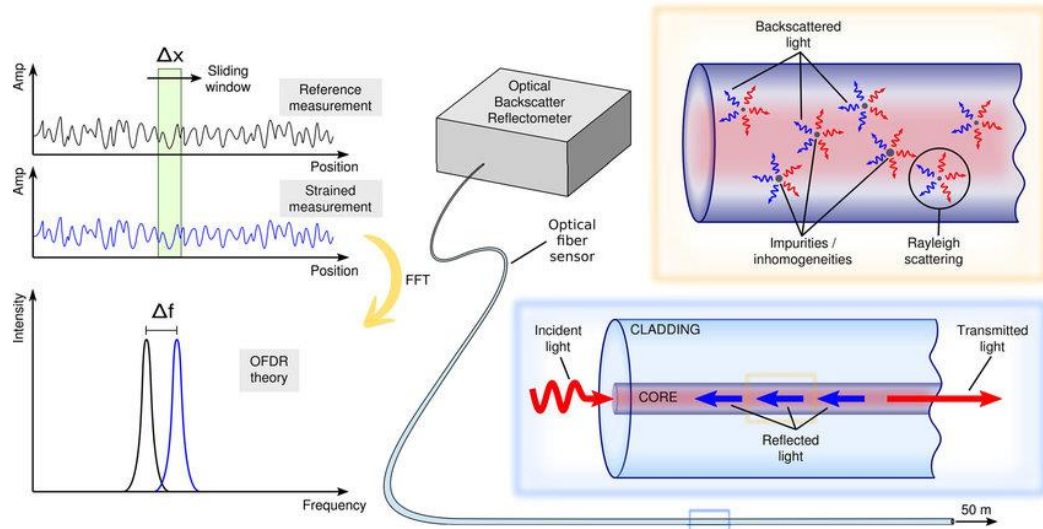

F. Scurti et al., "Quench Detection for High Temperature Superconductor Magnets: A Novel Technique Based on Rayleigh-Backscattering Interrogated Optical Fibers." *Superconductor Science & Technology* 29 (3): 03LT01. (2016)

Efforts are underway at various labs to develop new coatings for improving fiber thermal sensitivity at liquid helium temperatures, and better "decouple" temperature from strain. Implementing fiberoptic sensors for strain measurement in AUP magnets and for quench detection in CORC-based CCTs

- Hall array-based quench detection for HTS cables

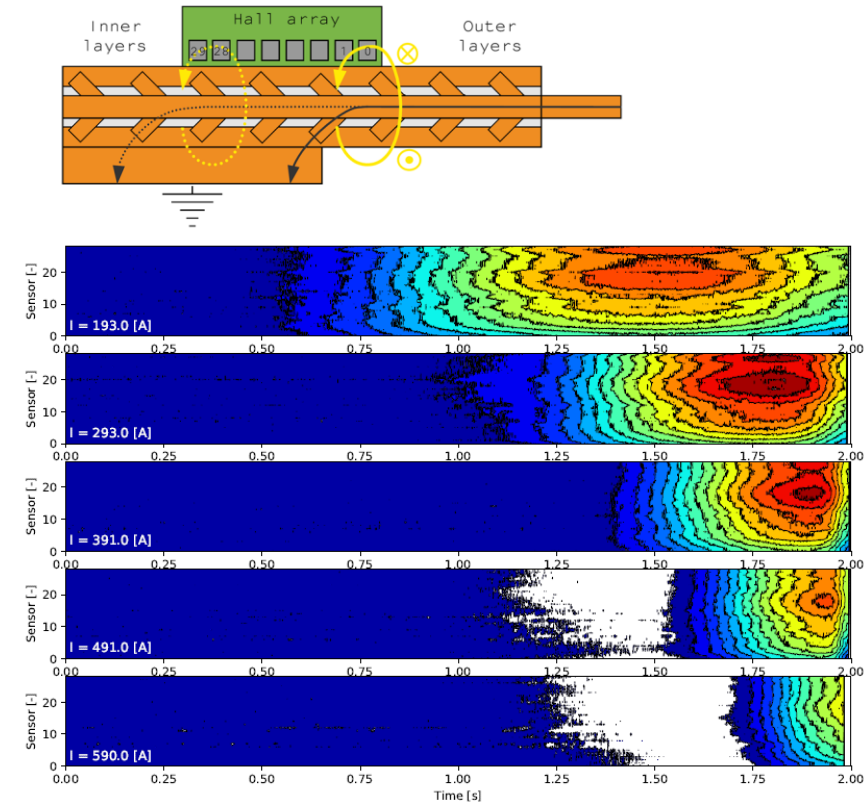

Current re-distribution along HTS CORC<sup>®</sup> cable terminals as function of time during quench development measured with the Hall array

*CORC<sup>®</sup> cable terminations with integrated Hall arrays for quench detection*, R. Teyber et al., *Supercond. Sci.Technol.*, 33, (2020)