



U.S. MAGNET
DEVELOPMENT
PROGRAM

Nb_3Sn SMCT status update

Igor Novitski, Michael Kifarkis, Alexander Zlobin,
Jodi Coghill, James Karambis, Edward Pieszchala

MDP GM

July 16, 2025

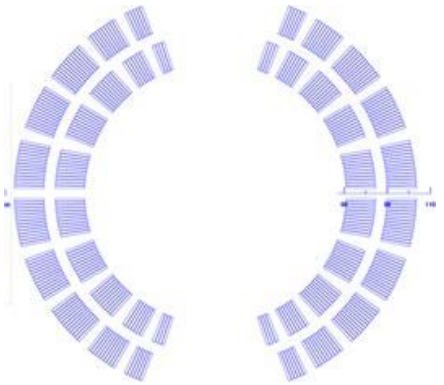

ID=123 mm, $B_{des} \sim 11$ T

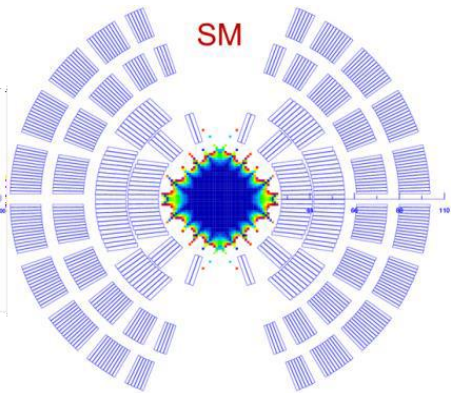

ID=60 mm, $B_{des} \sim 17$ T

I.a.M2	Development of the SMCT coil technology and test of stress management concept in a 2-layer 120-mm SMCTD1 with the field up to 11 T and in a 4-layer 60-mm dipole with the field up to 15 T.	Q1-Q2
I.a.M3		FY27

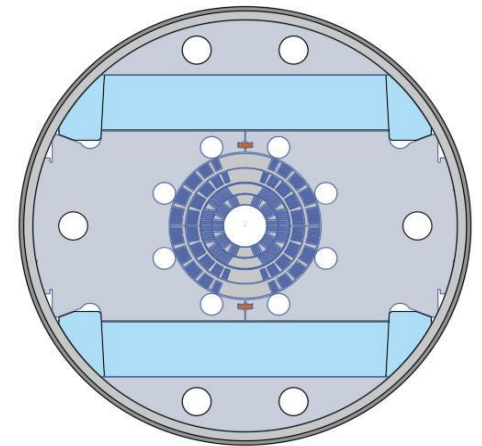
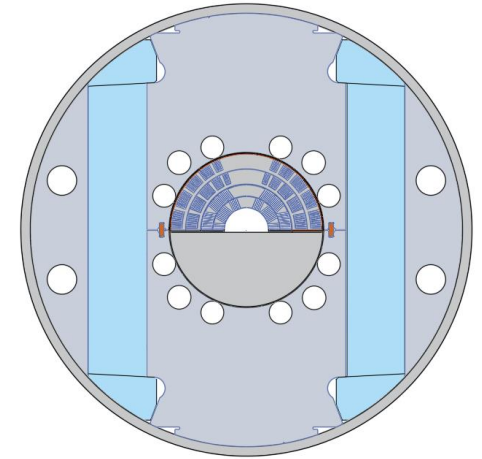

- SMCT D1 dipole
- Practice coil
- SMCT coil #2



SMCTD1: 60mm bore, 4-layer dipole with two 15T inner coils and two SMCT outer coil

reinforcement of axial and radial supports with thicker shell and end plates

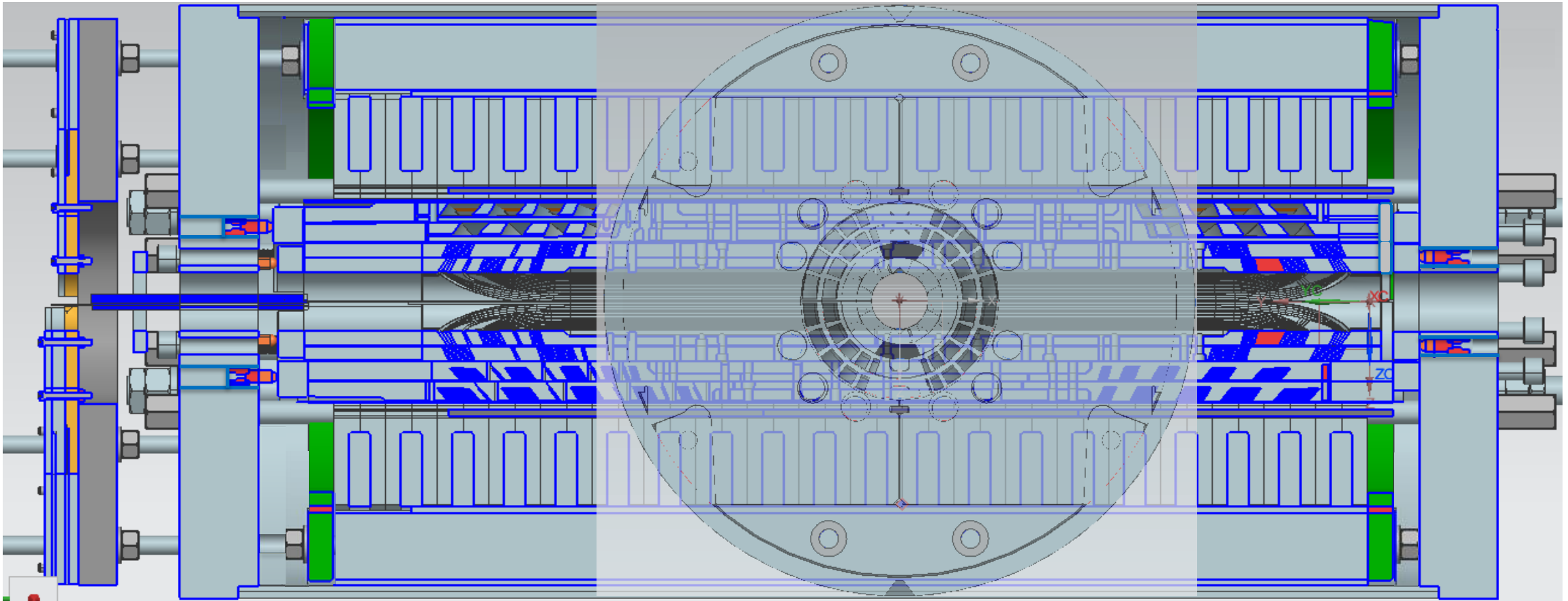

Design and drawings completed, parts in procurement



FEA for SMCT Mirror and Dipole Magnets

collaborative FEA work in progress – cross checking 3D results

ANSYS Workbench 3D model

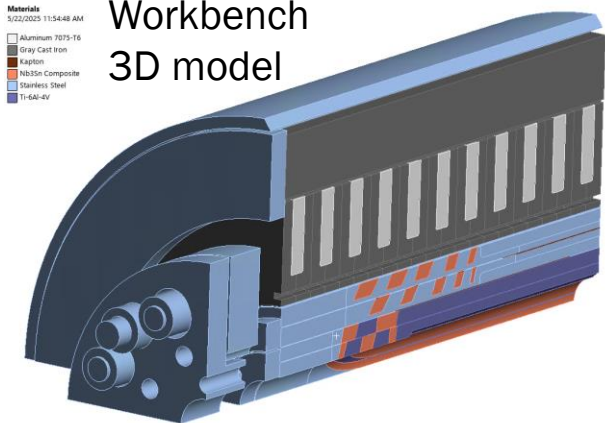

ANSYS 2D models

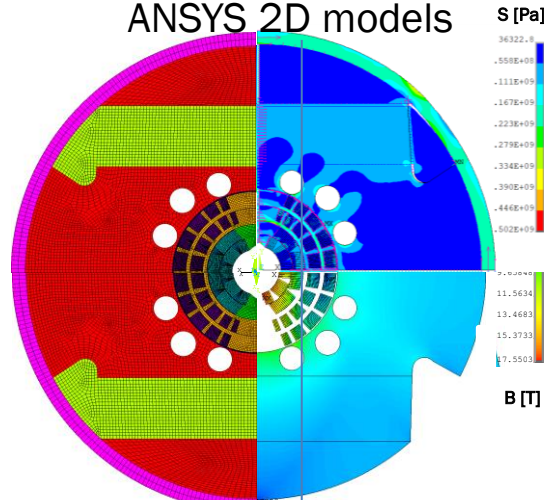

ANSYS MAXWELL 3D model

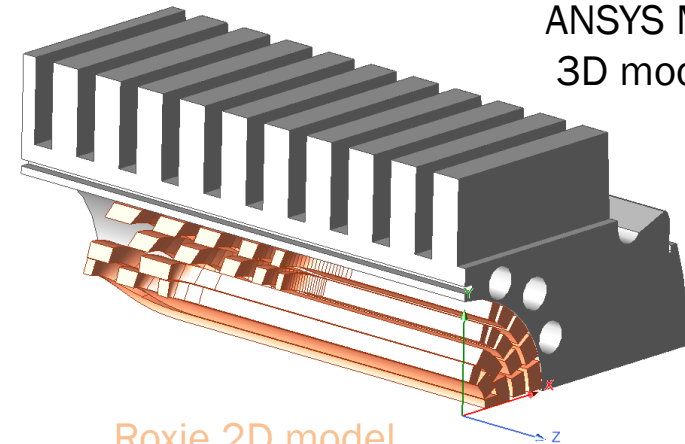

Roxie 2D model

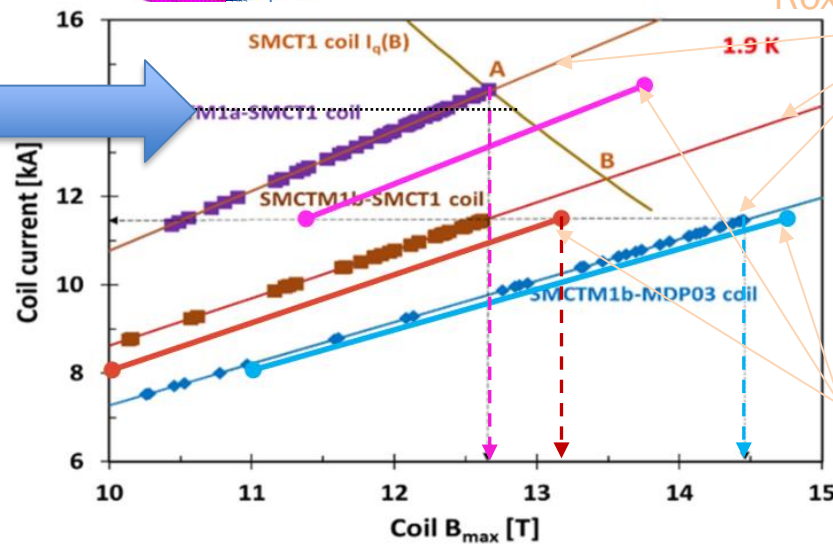

ANSYS 2D Maxwell 3D models

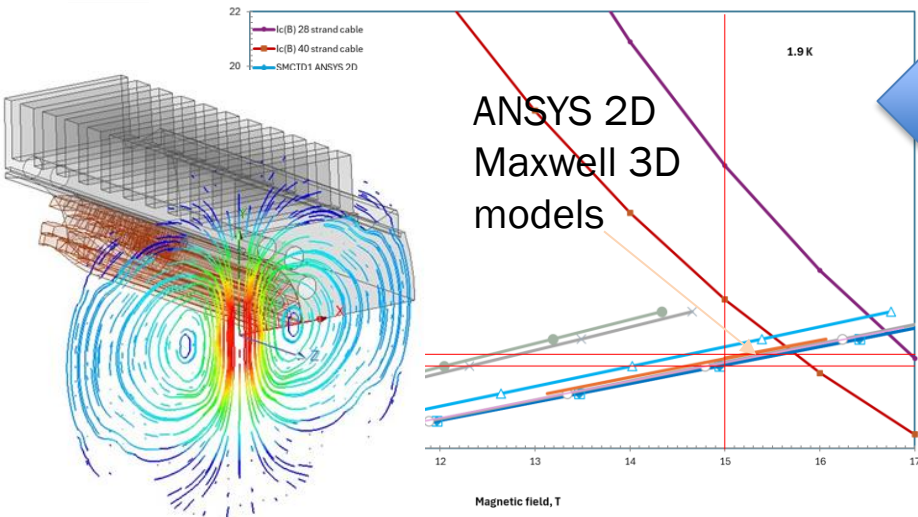

Opera 3D model

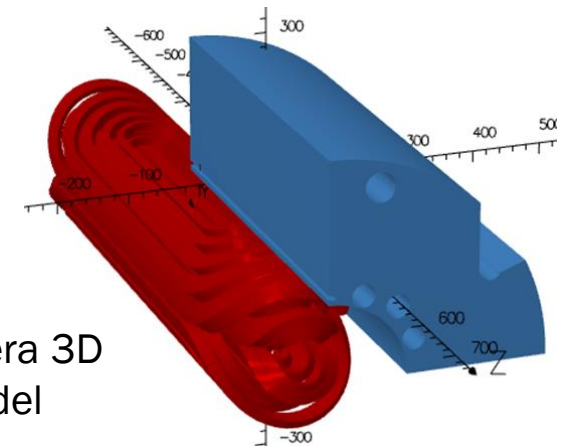

SMCT Dipole

VMS Mandrel Postprocessing for SMCT2 Coil



Holding fixture

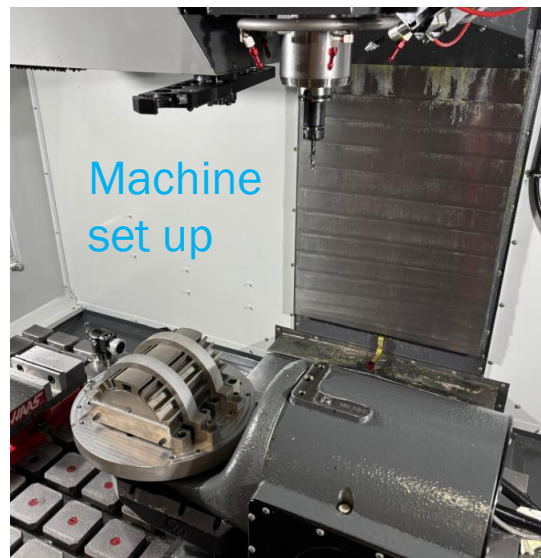

Machine set up



Parts after separation and w added holes

Plastic Mandrel of SMCT2 Coil for Practice Winding with Cooper Cable for TELENE impregnation test



3D printer



Cooper cable



Plastic mandrel

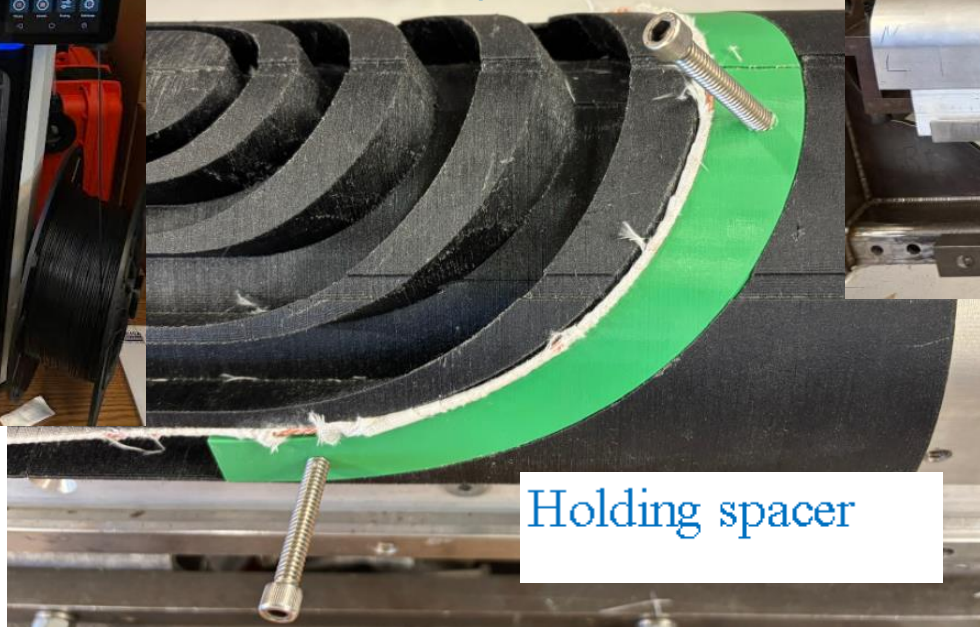

Holding spacer

Coil in Reaction Fixture, Thermal Models for 2D/3D FEA

20 C° – 660 C° -20 C°
thermocycle with
properties change

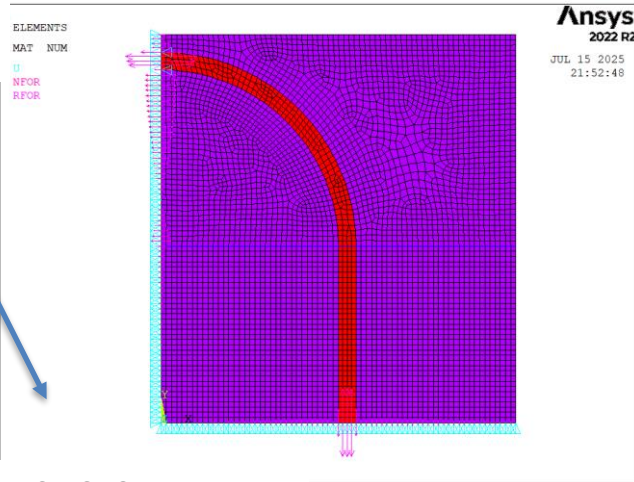
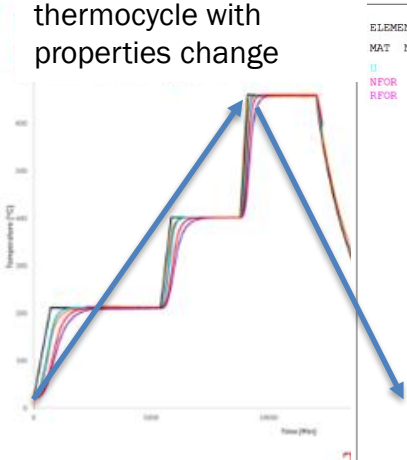

Materials
5/25/2025 9:32:04 AM

- Fiberglass Insulation
- Nb3Sn Anisotropic
- Stainless Steel 1

ANSYS
Workbench
3D model

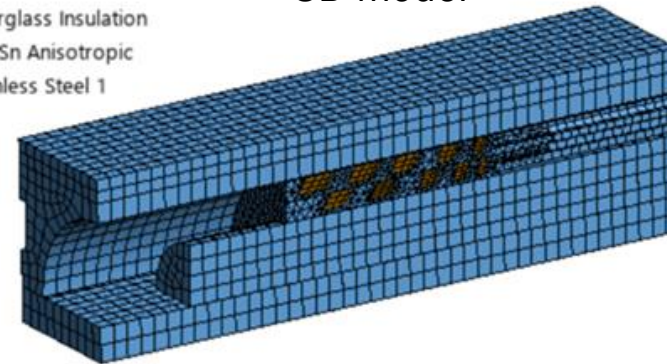

Z: 660C after reaction, Static Structural
Equivalent Stress-Coils
Type: Equivalent (von-Mises) Stress
Unit: MPa
Time: 3 s
5/25/2025 9:34:43 AM

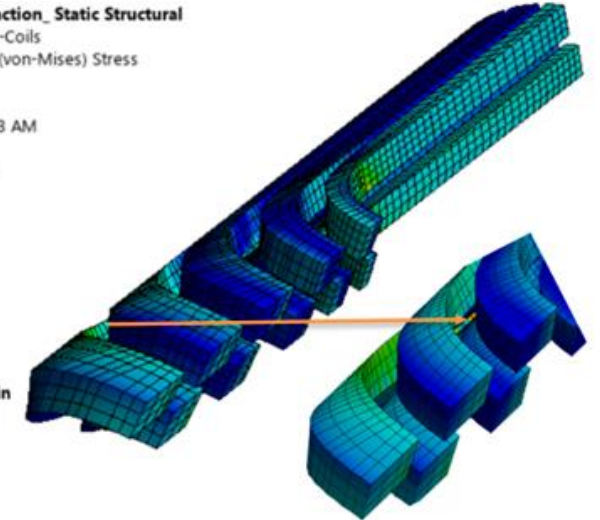
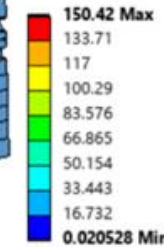

40 ANSYS 2D model

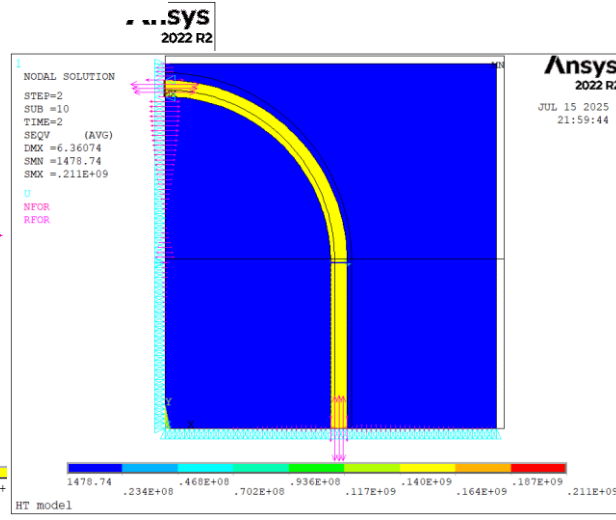
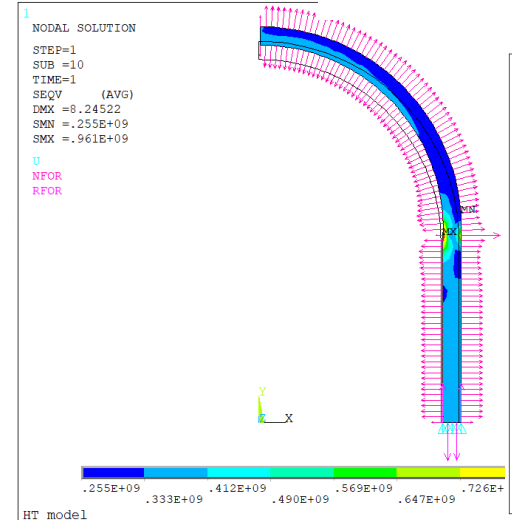

- Investigating cable degradation source during reaction – FEA
- Transient thermal FEA conducted – calculate delay time in coils
- Remove mandrel => reduce delay time of temperature
- Improve temperature uniformity during heat treatment
- Another possibility to overshoot controlled temperature

- Estimation of stresses during HT
- Looking at gap parameters btw grooves and conductors

Summary

- post-processing of 3D-printed coil mandrel
- 1m long practice coil, winding and impregnation with TELEN
- reaction tooling and HT analysis
- review of magnet mechanics, 3D FEA

- design work for SMCT coil with 28-strand cable (on hold)

} work in progress