

Probing the Nuclear Core in Next Generation Studies of SRCs

Misak Sargsian
Florida International University, Miami

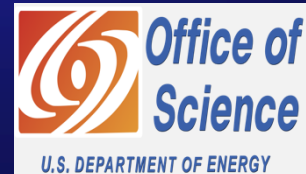

Outline:

1. Stability of Matter as a motivation to study the Nuclear Core

2. The QCD perspective of the Nuclear Core

3. Probing the core in the deuteron at very large internal mo

4. Possible relevance to the JLab anomaly

5. Measuring the size of the Nuclear Core

6. New Sum Rules for NN Interaction Potentials

- 1. Why there is a macroscopic matter, and it has a structure**
- 2. Stability of “Atomic Systems” in Electromagnetic Field**
- 3. Instability of “Atomic Systems” under Gravity**
- 4. Stability & Instability of Nuclear Matter under Gravity**
- 5. Stability of Atomic Nuclei & Repulsive Core**
- 6. What is Nuclear Repulsive Core and How to Probe it?**

1. Why there is a macroscopic matter, and it has a structure

- Because Atoms are Stable and "Large"

Dyson-Lenard Stability Theorem- 1967-68

Based on two fundamental properties of Quantum mechanics:

Uncertainty Principle and Concept of Indistinguishability of quantum particles

Uncertainty Principle

$$\frac{p^2}{2m} | \psi \rangle + V(r) | \psi \rangle = E | \psi \rangle$$
$$\langle T \rangle \sim \frac{\langle p^2 \rangle}{2m}$$
$$\langle E \rangle \approx \langle T \rangle + \langle V \rangle = \frac{\hbar^2}{2mr_0^2} - \frac{Z\alpha}{r_0}$$
$$\langle E \rangle \geq E_{min}$$

However, the stability condition does not make atoms large enough to bind to molecules and eventually to macroscopic objects

The radius of a typical orbit in this case $\frac{n^2 a_0}{Z}$

For Carbon $\approx 3.5 \times 10^{-11} \text{m}$

In Reality $\approx 7.0 \times 10^{-11} \text{m}$

1. Why there is a macroscopic matter, and it has a structure

- Because atoms are Stable and "Large"

Dyson-Lenard Stability Theorem- 1967-68

Indistinguishability of quantum particles

$$P_{i,j}\psi(r_1, r_2, \dots, r_i, \dots, r_j, \dots, r_n) = \lambda\psi(r_1, r_2, \dots, r_j, \dots, r_i, \dots, r_n)$$

$$P_{i,j}^2\psi(r_1, r_2, \dots, r_i, \dots, r_j, \dots, r_n) = \psi(r_1, r_2, \dots, r_i, \dots, r_j, \dots, r_n)$$

$\lambda = \pm 1$ - Fermions, + Bosons

$$\psi(r_1, r_2) = \frac{1}{2} [\psi_1(r_1)\psi_2(r_2) - \psi_1(r_2)\psi_2(r_1)]$$

Pauli Exclusion principle makes atoms large to produce structures beyond atom

2. Stability of “Atomic Systems” in Electromagnetic Field

- Criticality of “ultrarelativistic” atoms

Are ultrarelativistic electrons stable in atoms? - Supercritical Charge

In this case: $\langle T \rangle \sim c \langle p \rangle$ $\bar{E} = \langle T \rangle + \langle V \rangle \approx \frac{1}{r_0} - \frac{Z\alpha}{r_0}$

For $Z_c \alpha \geq 1$

Atom is
unstable...

Pomeranchuk & Smorodinsky 1945

However, Dirac Vacuum saves the atom

Zeldovich & Popov 1971

Once $\langle E \rangle \leq -m_e$ - vacuum decays to e^+e^- pair reducing Z_c by one unit

The prediction was $Z_c \rightarrow (Z_c - 1) + e^+$ W. Greiner 1977

3. Instability of “Atomic Systems” under Gravity

However, the system of electrons will be unstable in the strong gravitational field

In this case $\langle T \rangle \sim c \langle p \rangle$ $\bar{E} = \langle T \rangle + \langle V \rangle \sim \frac{1}{r_0} - \frac{GM}{r_0}$

At some critical density of matter system of electrons will not be stable in the gravitational field

Quantum Vacuum will not help in this case

Chandrasekhar limit!

Lieb, Thirring 1975s

4. Stability & Instability of Nuclear Matter under Gravity

Chandrasekhar limit for the system of noninteracting neutrons!

- Stable Neutron Stars at 0.6 Solar Masses

Oppenheimer & Volkoff 1939

- “black holes”

Oppenheimer & Snyder 1939 “On Continued Gravitational Contraction”

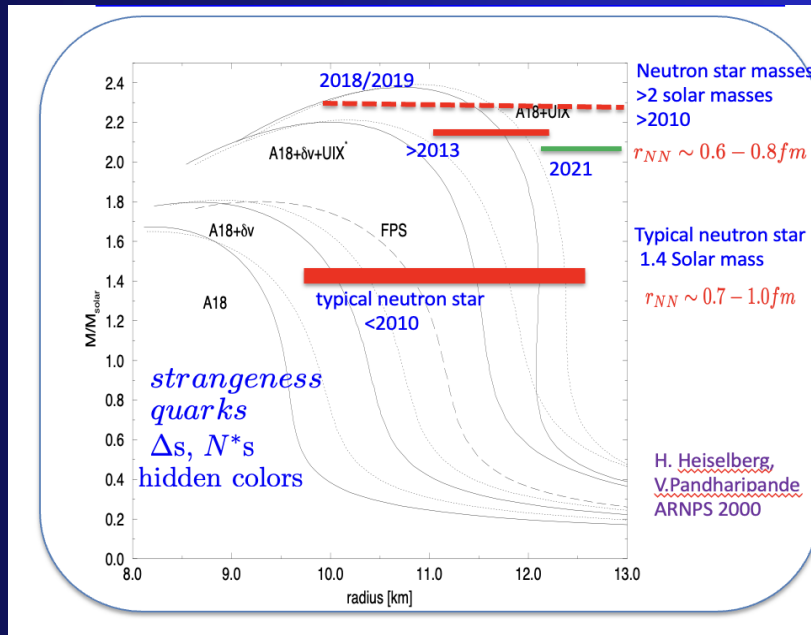

5. Stability of Atomic Nuclei & Repulsive Core

- NN force is attractive: But Nuclei are Stable

“If the two-body forces are everywhere attractive and if many-body forces are neglected then the nucleon pairs are sufficiently close to take advantage of attractive interactions and a collapsed state of nuclear matter results “

G. Breit and E.P. Wigner, Phys. Rev. 53, 998 (1938).

Many body forces keeping nucleus stable

- Nuclear density will not saturate

- The universe will be dominated by high z nuclei

- The problem exists also on astrophysical scale

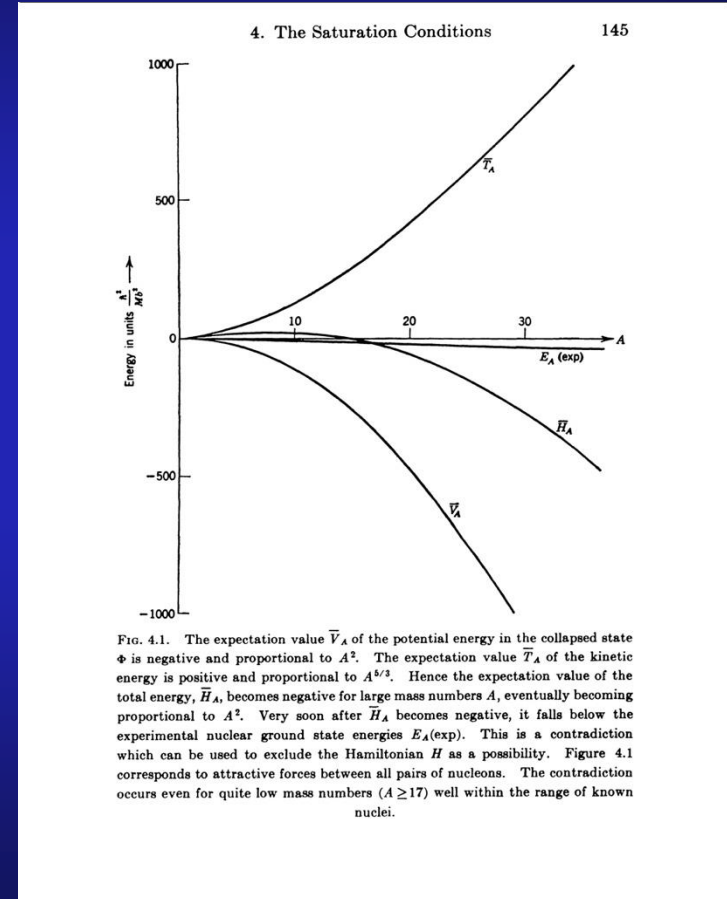

5. Stability of Atomic Nuclei & Repulsive Core

Jastrow 1951 assumed the existence of the infinite hard core to explain the angular distribution of pp cross section at 340 MeV ($r_0=0.6\text{fm}$)

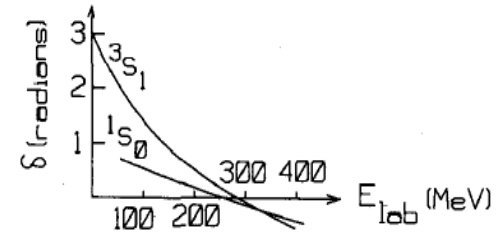
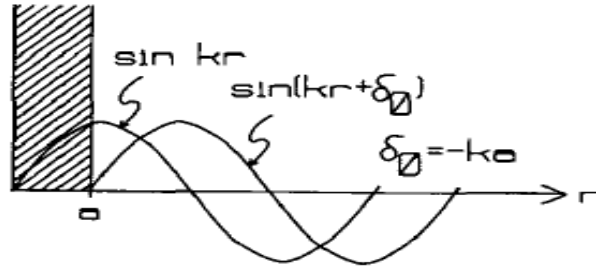
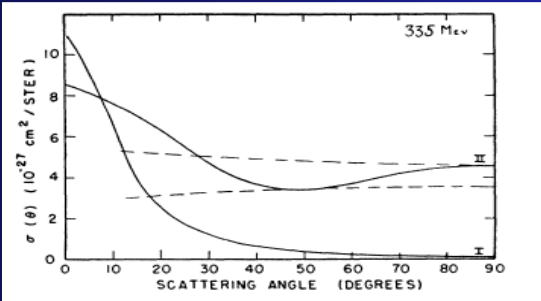

Non-monotonic NN central potential with the repulsive core was introduced: Brueckner & Watson 1953 to obtain nuclear density saturation

Modern NN Potentials

$$V^{2N} = V_{EM}^{2N} + V_{\pi}^{2N} + V_R^{2N}$$

$$V_R^{2N} = V^c + V^{l^2} L^2 + V^t S_{12} + V^{ls} L \cdot S + v^{ls^2} (L \cdot S)^2$$

$$V^i = V_{int,R} + V_{core}$$

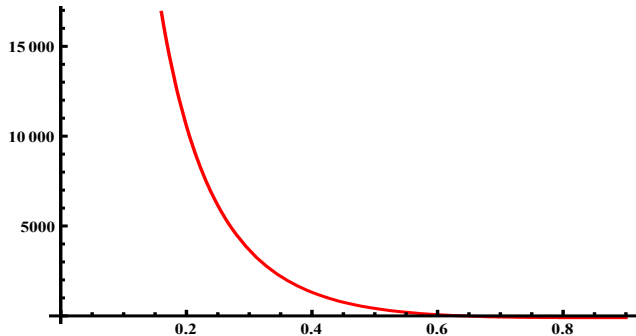

$$V_{core} = \left[1 + e^{\frac{r-r_0}{a}} \right]^{-1}$$

60's

Currently: Probed NN structure up to $> 0.8\text{fm}$

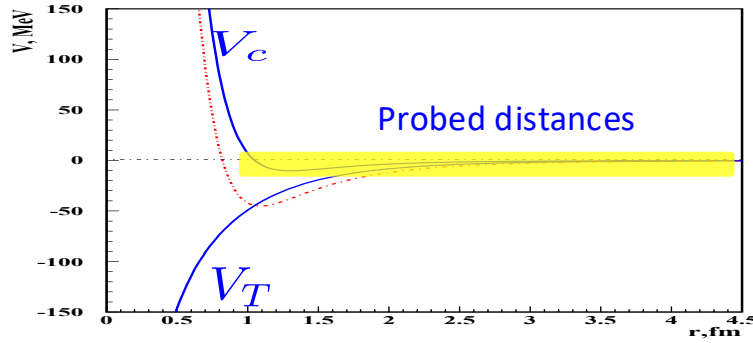

Next: NN – Repulsive Core

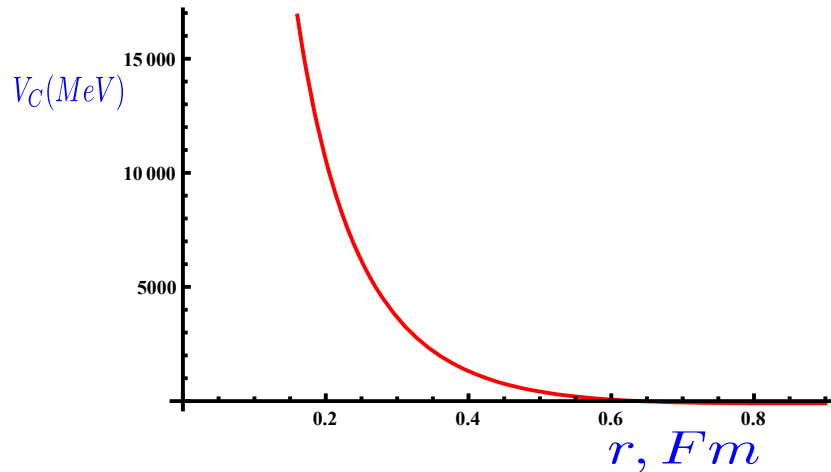

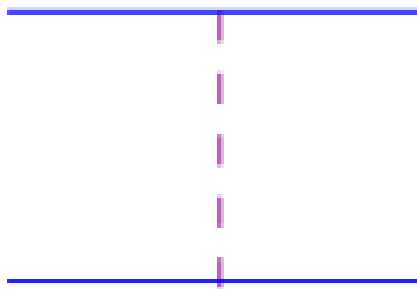

$\sigma, \pi, \rho, \omega, \dots$

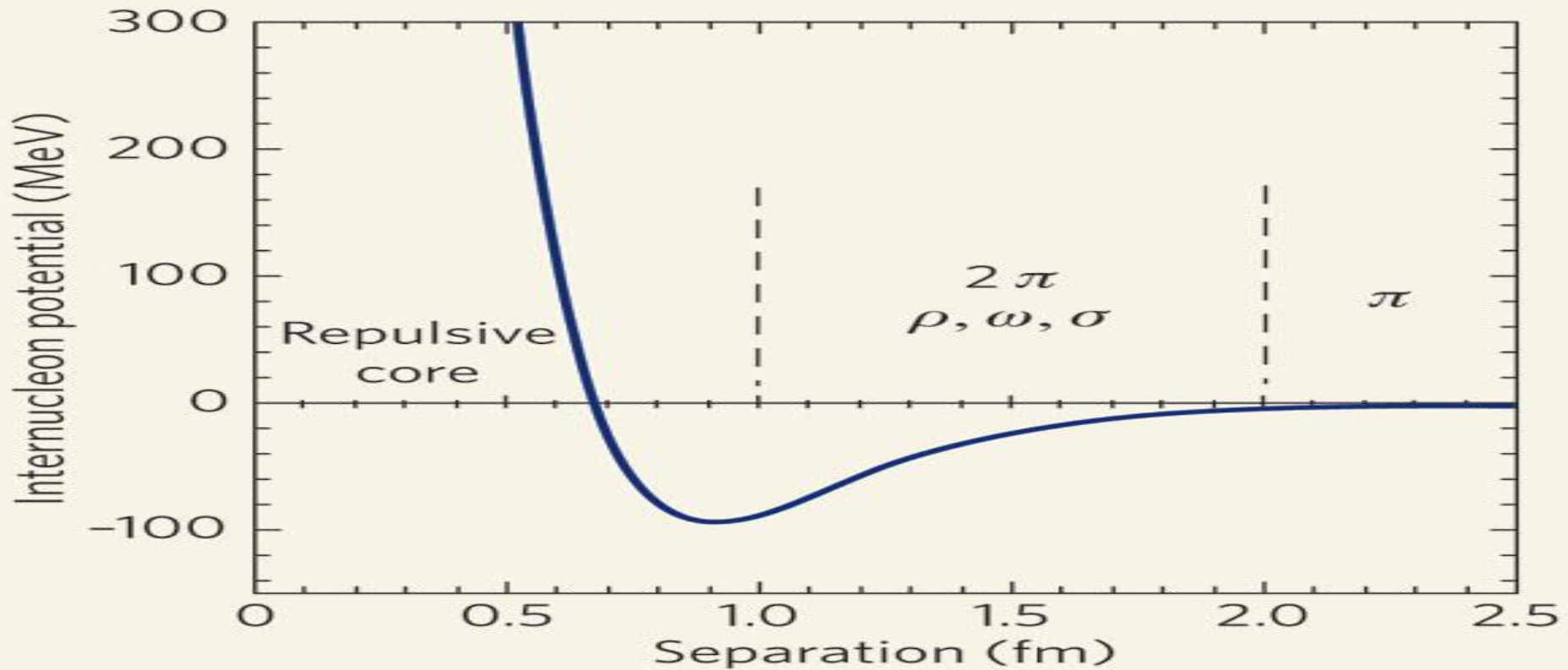

Field Theory of Nucleons & Mesons 1947-

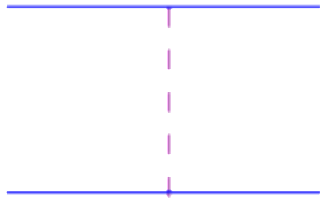

$\sigma, \pi, \rho, \omega, \dots$

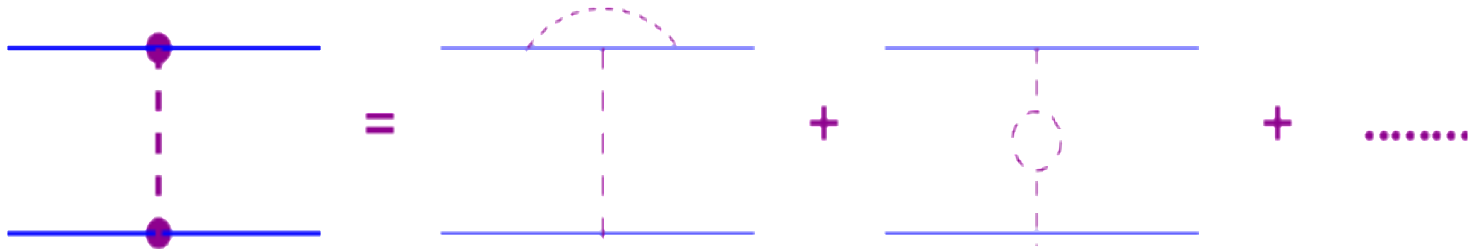

Pomeranchuk, Landau - 1950's

$$g^2(\Lambda^2) = \frac{g^2}{1 - 5\left(\frac{g^2}{4\pi}\right)\ln\left(\frac{\Lambda^2}{m^2}\right)}$$

$$\alpha_{em}(Q^2) = \frac{\alpha_{em}(\mu^2)}{1 - \frac{\alpha_{em}(\mu^2)}{3\pi}\ln\frac{Q^2}{\mu^2}}$$

$Q = m_e e^{\frac{3\pi}{2\alpha}} \sim 10^{277} \text{ GeV}$

Infinite interaction occurs at transferred momenta approx **500 MeV/c** or at inter-nucleon distances $1 \sim \text{Fm}$.

It seems we have a problem about which the Nature is not aware of Y.Pomeranchuk

All formal quantum field theories with Yukawa type interactions contain the problem of the "Zero Charge"

Pomeranchuk, Sudakov, Ter-Martirosyan, Phys. Rev. 1956

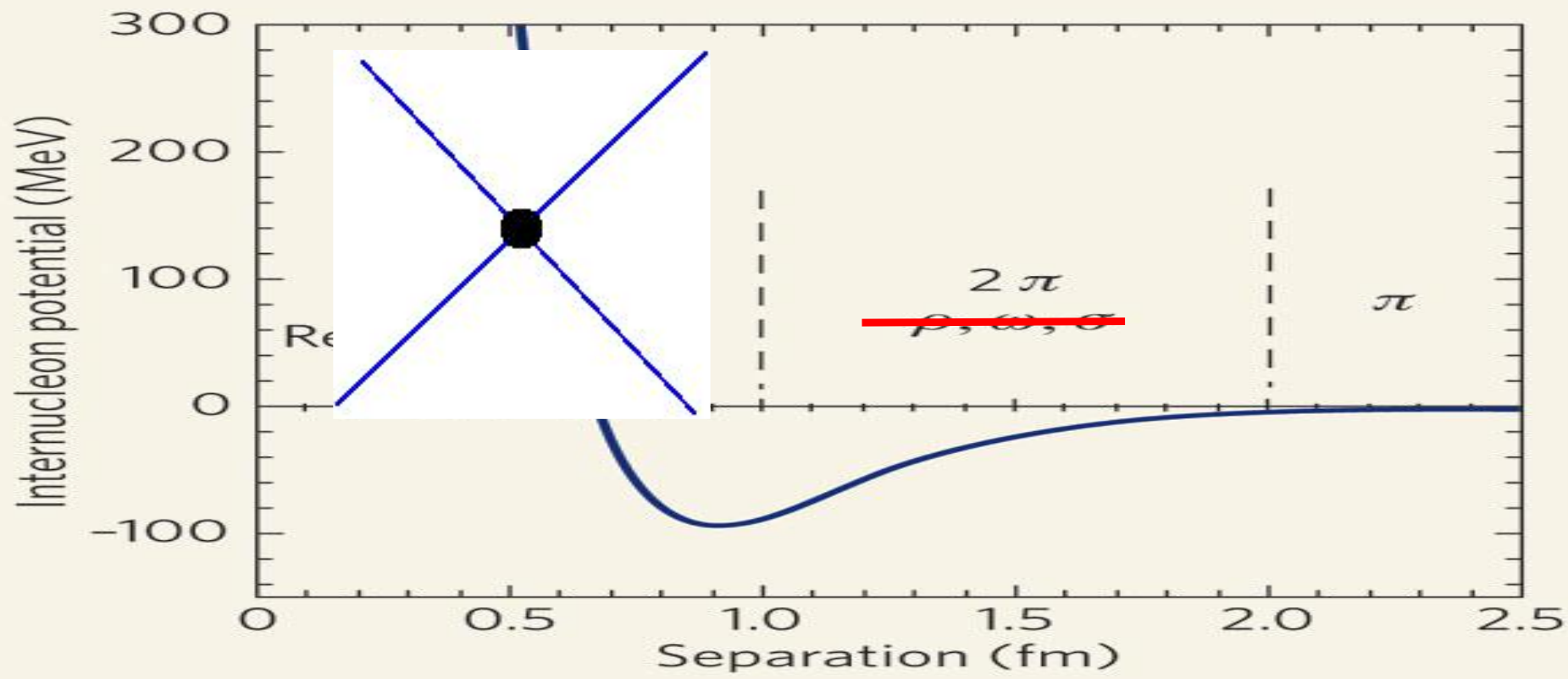
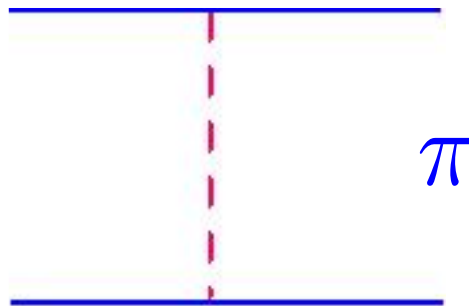
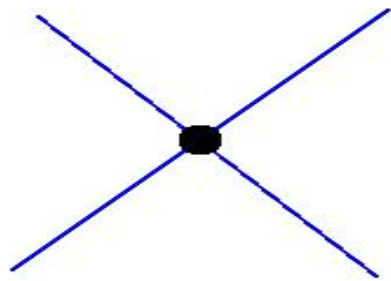

QCD

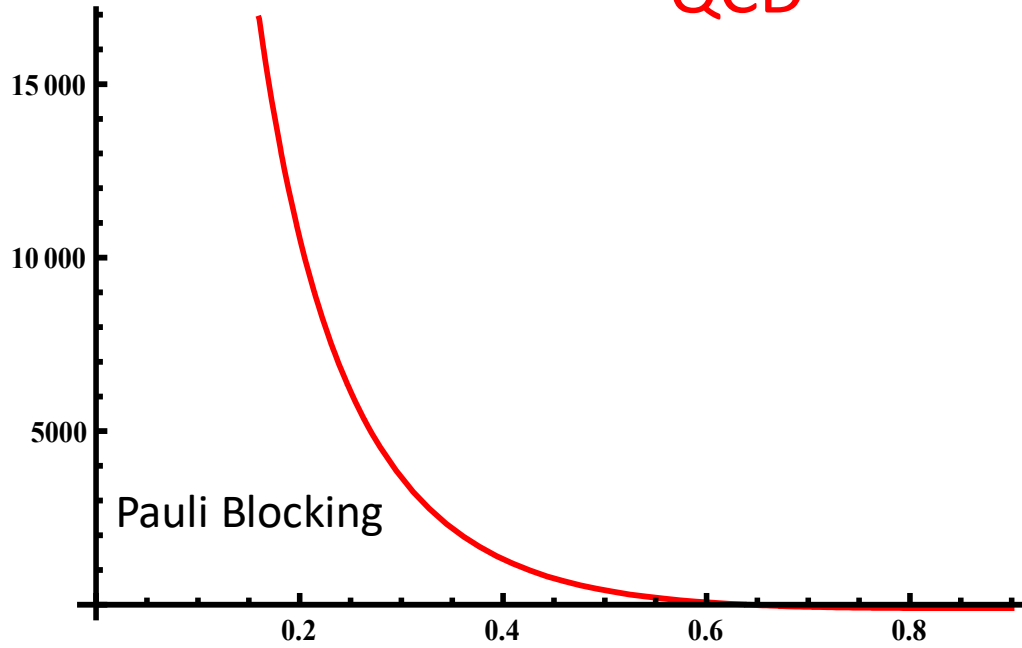

Contradicts Neutron Star Observations:
will predict masses not more than 0.1 - 0.6 Solar mass

Lattice Calculations

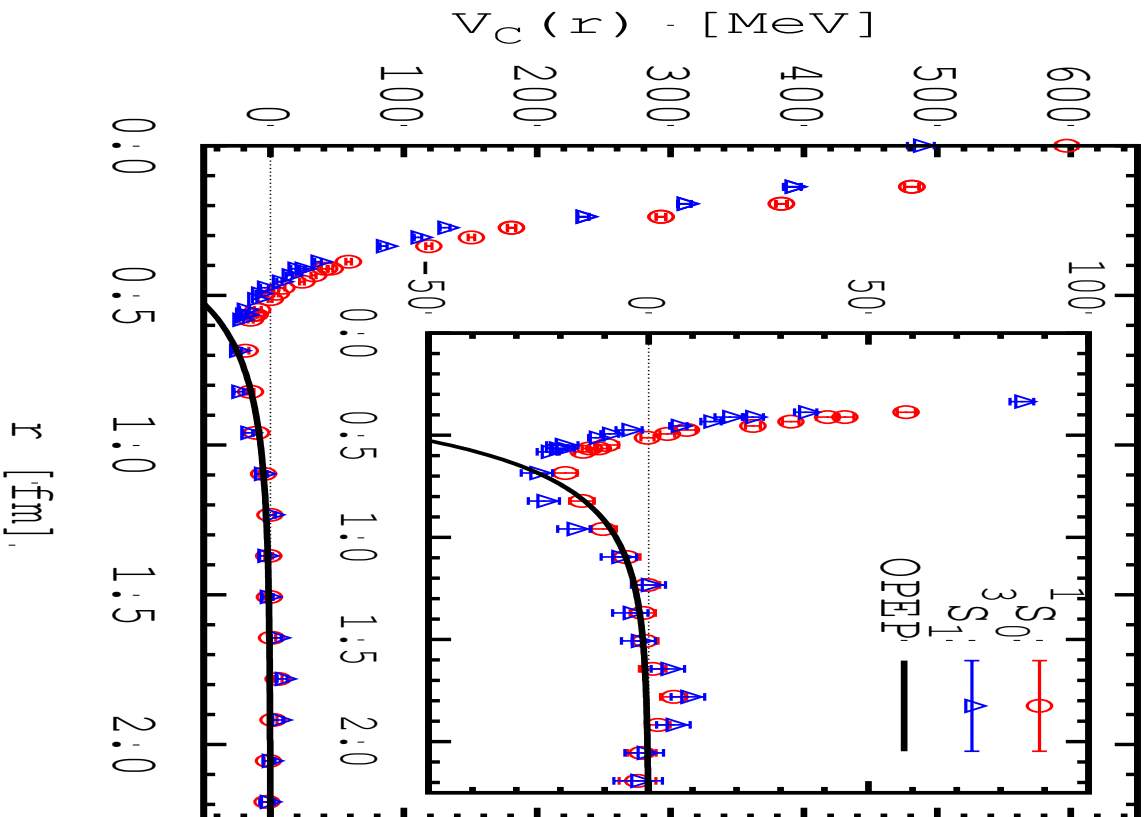

QCD

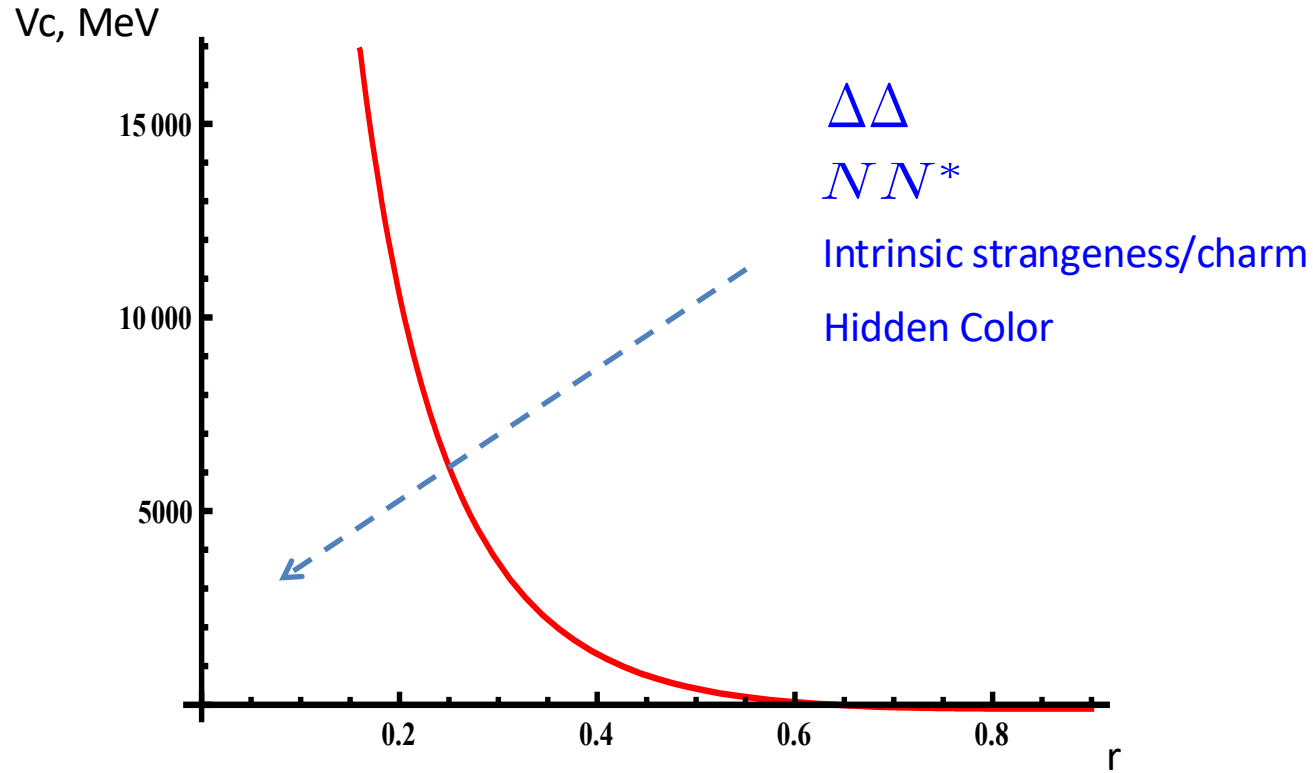

~80% hidden color
Brodsky, Ji, Lepage, PRL 83

Probing the Deuteron at Short Distances

$$\Psi_d = \Psi_{pn} + \Psi_{\Delta\Delta} + \Psi_{NN^*} + \Psi_{hc} \cdots$$

$$\Psi_{hc} = \Psi_{N_c, N_c}$$

$$\Psi_{T=0, S=1}^{6q} = \sqrt{\frac{1}{9}} \Psi_{NN} + \sqrt{\frac{4}{45}} \Psi_{\Delta\Delta} + \sqrt{\frac{4}{5}} \Psi_{CC}$$

The NN core can be due to the orthogonality of

$$\langle \Psi_{N_c, N_c} | \Psi_{N, N} \rangle = 0$$

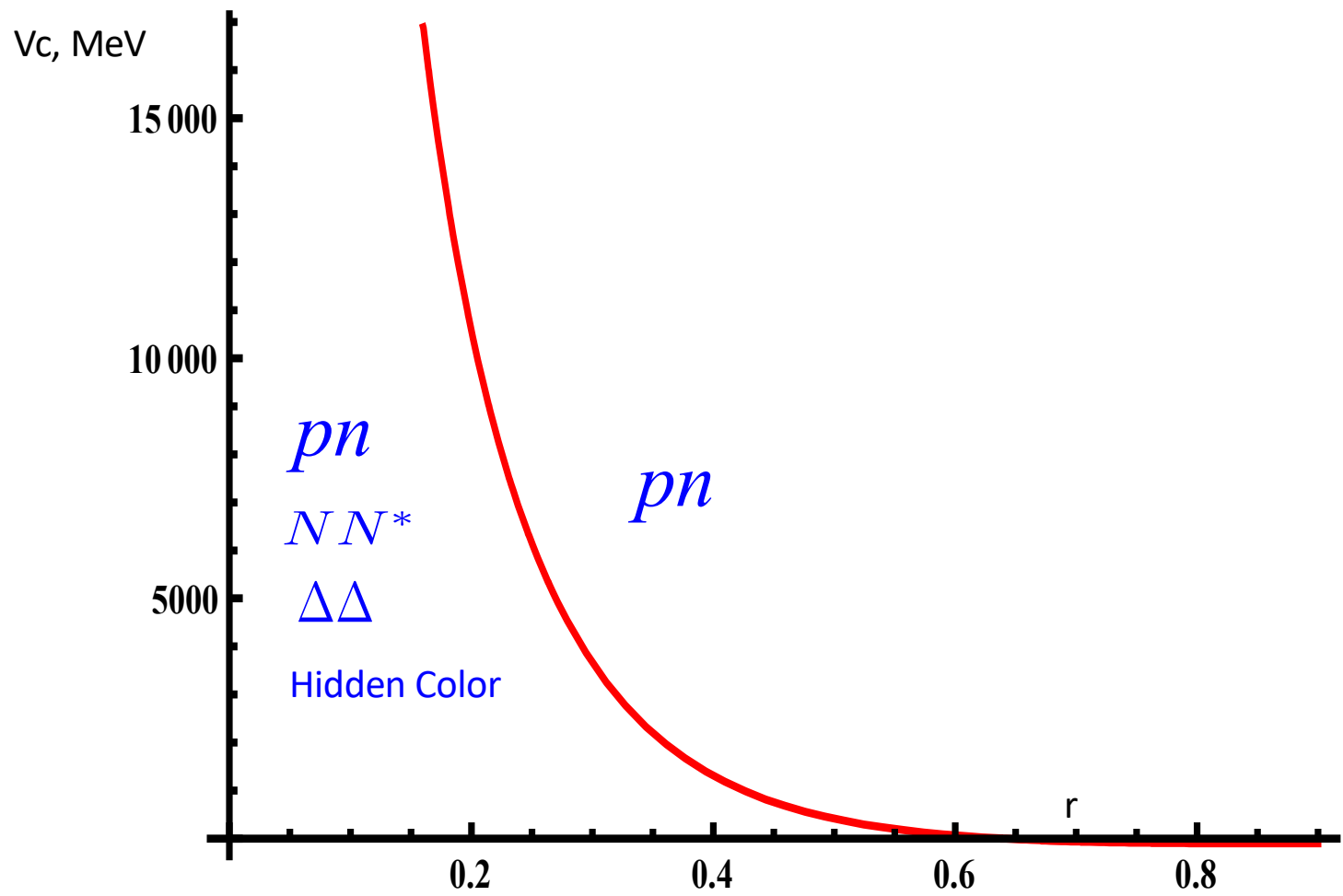

Probing NN interaction at very short distances

Considering reaction: $e + d \rightarrow e' + p_f + n$

$$|p_i| = |p_f - q| > 550 \text{ MeV}/c$$

$$|p_i| = |p_f - q| \gtrsim 800 \text{ MeV}/c$$

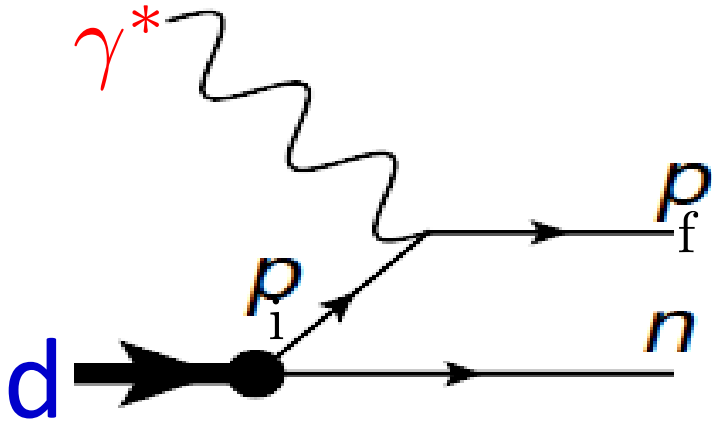

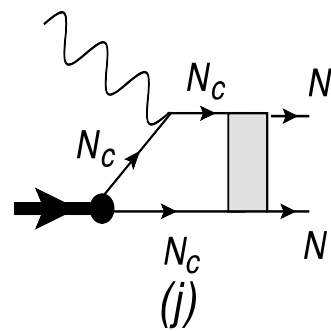
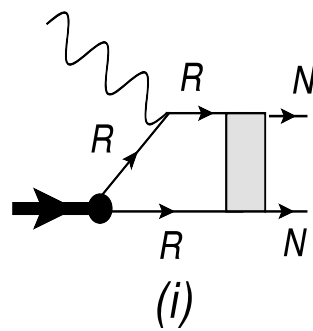
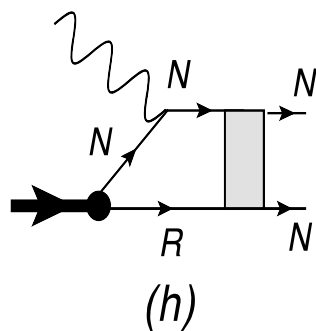
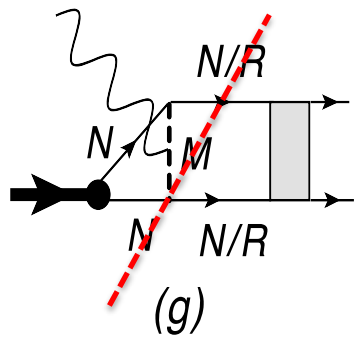
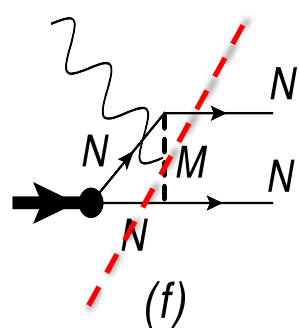
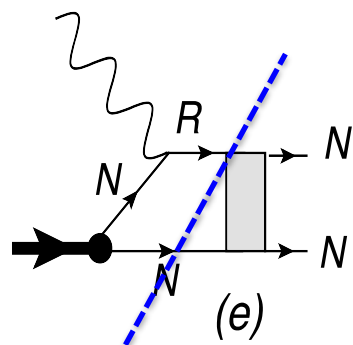
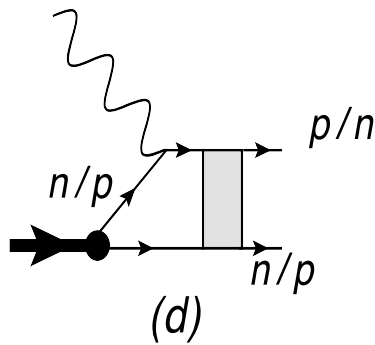
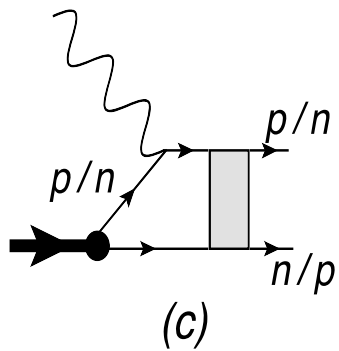
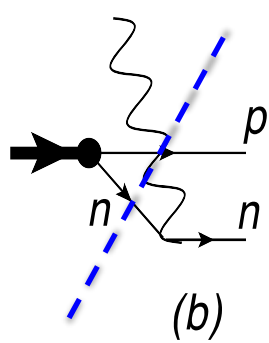
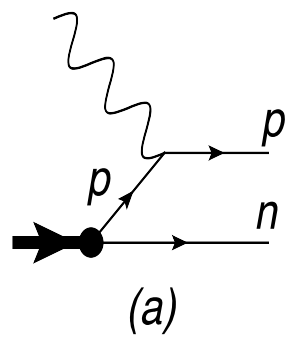

Considering mainly high Q^2 $d(e,e'N)N$ reaction

Theory of high energy semi-inclusive electro-nuclear processes:

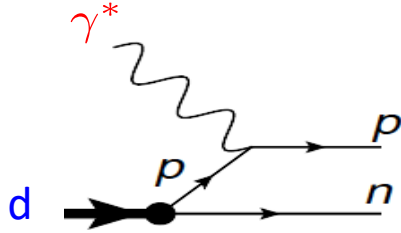

$$|p_i| = |p_f - q| \leq 550 \text{ MeV}/c$$

Deuteron consist of proton and neutron

Exclusiveness of the reaction as an advantage in probing unintegrated density matrix of the deuteron at given missing momentum

not entirely true: final state hadronic interactions are never dynamically small

In High Energy and Momentum Transfer limit: $Q^2 > 1\text{GeV}^2$: MEC is dynamically suppressed, Delta is possible to suppress both kinematically and dynamically

For FSI eikonal regime is established: allowed to develop **self-consistent theoretical framework** that allows to account for the short distance nuclear dynamics

Probing Deuteron at Small Distances at large Q^2

MS PRC 2010

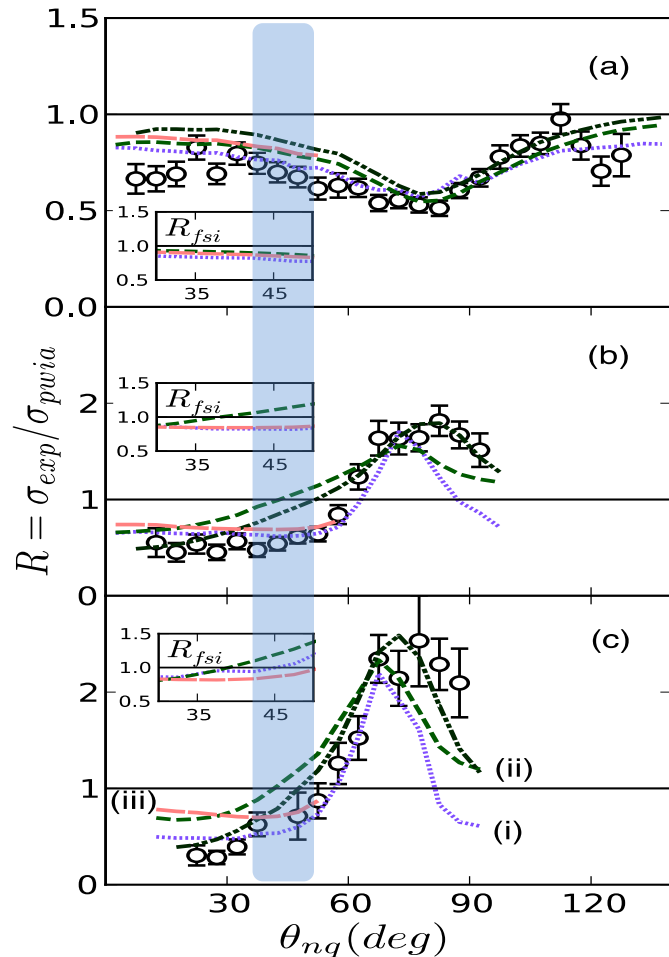

JLab, $Q^2 = 3.5 \text{ GeV}^2$

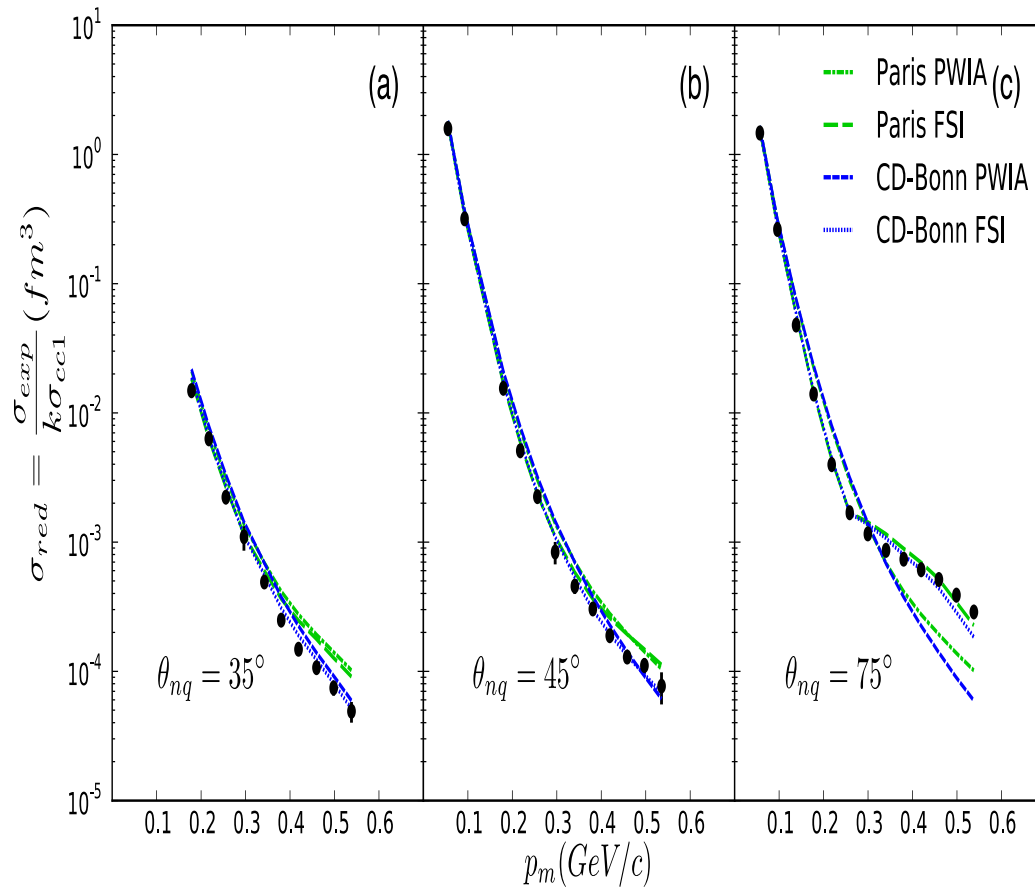

Boeglin et al PRL 2011, deuteron probed at up to 550 MeV/c

Possibility of Experimental Verification

Considering reaction: $e + d \rightarrow e' + p_f + n$

$$|p_i| = |p_f - q| \gtrsim 800 \text{ MeV}/c$$

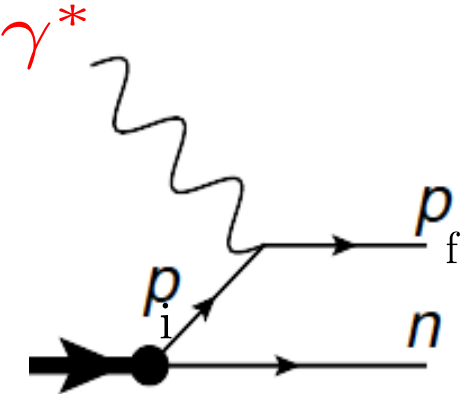

PAC-36, 2010 (experimental proposal, W. Boeglin, PI)

- E12-10-003 ($p_m \square 300 \text{ MeV}$): “Deuteron Electro-Disintegration at Very High Missing Momentum”

Rating: B+

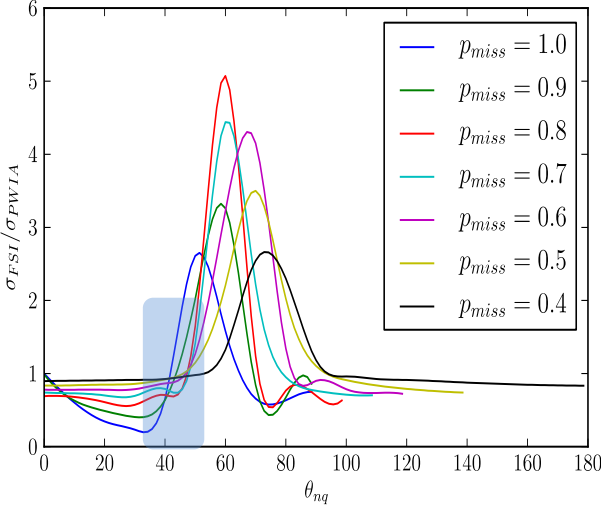

data are essential to constrain further theory developments. Overall the experiment was viewed very highly; the lower rating simply reflects the likelihood that the data will not reveal any particular surprise and that their impact may thus be limited to experts in the field.

Probing NN interaction at very short distances

Considering reaction: $e + d \rightarrow e' + p_f + n$

$$|p_i| = |p_f - q| > 550 \text{ MeV}/c$$

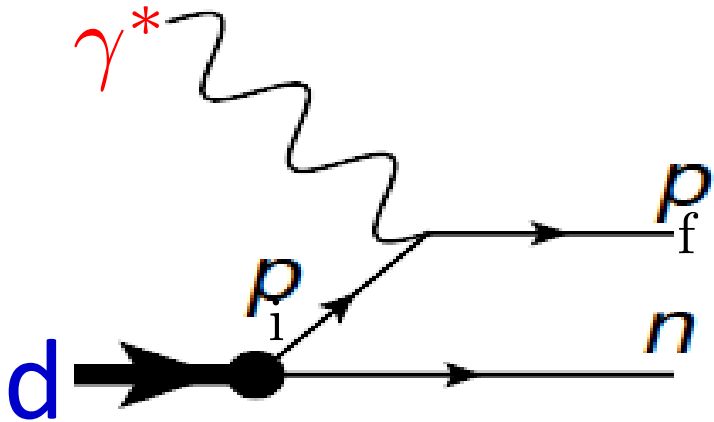

Some Paradigm Shift

Our current mindset about deuteron is fully non-relativistic, the observation that it has total spin, $J=1$ and parity, $P=+$, together with the relation that for non-relativistic wave function, $P = (-1)^l$, one concludes that the deuteron consists of S- and D- partial waves for proton-neutron system.

Paradigm Shift: The above reaction at high Q^2 , measures the probability of observing proton and neutron in the deuteron at very large relative momenta. In such a formulation the deuteron is not a composite system consisting of proton and neutron but it is a composite pseudo - vector ($J=1, P=+$) "particle" from which one extracts proton and neutron.

How such a proton and neutron produced at such extremal conditions is related to the dynamical structure of Light-Front deuteron wave function, which may include internal elastic $pn \rightarrow pn$ as well as inelastic $\Delta\Delta \rightarrow pn, N^*N \rightarrow pn$ or $N_C N_C \rightarrow pn$ transitions.

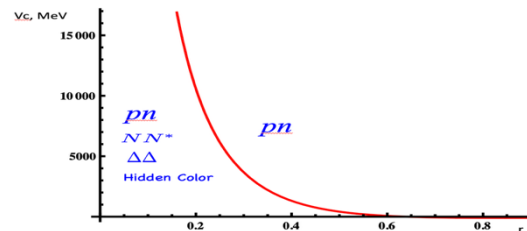

New Structure in the Deuteron and possible non-nucleonic components

M.S & Frank Vera PRL 2023

Paradigm shift:

- consider a deuteron not a nucleus that consist of proton and neutron
- but **pseudovector composite particle** from which we **extract** proton and neutron

- Light-Front Deuteron wave function

$$\psi_d^{\lambda_d}(\alpha_i, p_{\perp}, \lambda_1 \lambda_2) = - \frac{\bar{u}(p_2, \lambda_2) \bar{u}(p_1, \lambda_1) \Gamma_d \chi^{\lambda_d}}{\frac{1}{2} (m_d^2 - 4 \frac{m_N^2 + p_{\perp}^2}{\alpha_i (2 - \alpha_i)}) \sqrt{2} (2\pi)^3}$$

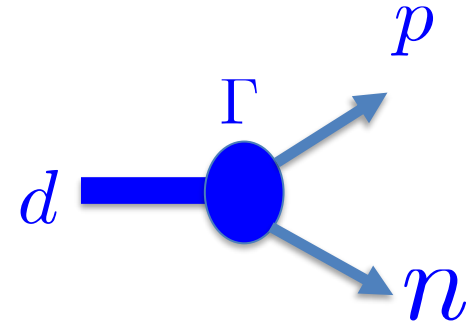

- Absorbing the energy denominator into the vertex function and using crossing symmetry

$$\psi_d^{\mu}(\alpha_i, p_{\perp}, \lambda_1, \lambda_2) = -\bar{u}(p_2, \lambda_2) \Gamma_d^{\mu}(k) \frac{(i\gamma_2 \gamma_0)}{\sqrt{2}} \bar{u}(p_1, \lambda_1)^T = - \sum_{\lambda'_1} \bar{u}(p_1, \lambda_1) \Gamma_d^{\mu} \gamma_5 \frac{\epsilon_{\lambda_1, \lambda'_1}}{\sqrt{2}} u(p_1, \lambda'_1)$$

$$\psi_d^\mu(\alpha_i, p_\perp, \lambda_1, \lambda_2) = -\bar{u}(p_2, \lambda_2) \Gamma_d^\mu(k) \frac{(i\gamma_2 \gamma_0)}{\sqrt{2}} \bar{u}(p_1, \lambda_1)^T = -\sum_{\lambda'_1} \bar{u}(p_1, \lambda_1) \Gamma_d^\mu \gamma_5 \frac{\epsilon_{\lambda_1, \lambda'_1}}{\sqrt{2}} u(p_1, \lambda'_1)$$

- Γ_d^μ - is a four-vector, which can be constructed in a most general form satisfying time reversal, parity and charge conjugate symmetries

- Because the deuteron is a bound system, in addition to on-shell p_1 and p_2 four momenta one introduces

$$\Delta^\mu \equiv p_1^\mu + p_2^\mu - p_d^\mu \equiv (\Delta^-, \Delta^+, \Delta_\perp) = (\Delta^-, 0, 0)$$

$$\Delta^- = p_1^- + p_2^- - p_d^- = \frac{m_N^2 + k_\perp^2}{p_1^+} + \frac{m_N^2 + k_\perp^2}{p_2^+} - \frac{M_d^2}{p_d^+} = \frac{1}{p_d^+} \left[\frac{4(m_N^2 + k_\perp^2)}{\alpha_1(2 - \alpha_1)} - M_d^2 \right] = \frac{4}{p_d^+} \left[m_N^2 - \frac{M_d^2}{4} + k^2 \right]$$

- Constructed vertex:

$$\Gamma_d^\mu = \Gamma_1 \gamma^\mu + \Gamma_2 \frac{(p_1 - p_2)^\mu}{2m_N} + \Gamma_3 \frac{\Delta^\mu}{2m_N} + \Gamma_4 \frac{(p_1 - p_2)^\mu \not{\Delta}}{4m_N^2} + i\Gamma_5 \frac{1}{4m_N^3} \gamma_5 \epsilon^{\mu\nu\rho\gamma} (p_d)_\nu (p_1 - p_2)_\rho (\Delta)_\gamma + \Gamma_6 \frac{\Delta^\mu \not{\Delta}}{4m_N^2}$$

High Momentum Transfer Kinematics

For large Q^2 limit, Light-Front momenta for the reaction are chosen as follows:

$$p_d^\mu \equiv (p_d^-, p_d^+, p_{d\perp}) = \left(\frac{Q^2}{x\sqrt{s}} \left[1 + \frac{x}{\tau} - \sqrt{1 + \frac{x^2}{\tau}} \right], \frac{Q^2}{x\sqrt{s}} \left[1 + \frac{x}{\tau} + \sqrt{1 + \frac{x^2}{\tau}} \right], 0_\perp \right)$$
$$q^\mu \equiv (q^-, q^+, q_\perp) = \left(\frac{Q^2}{x\sqrt{s}} \left[1 - x + \sqrt{1 + \frac{x^2}{\tau}} \right], \frac{Q^2}{x\sqrt{s}} \left[1 - x - \sqrt{1 + \frac{x^2}{\tau}} \right], 0_\perp \right)$$

where $s = (q + p_d)^2$, $\tau = \frac{Q^2}{M_d^2}$ and $x = \frac{Q^2}{M_d q_0}$, with q_0 being virtual photon energy in the deuteron rest frame.

- One observes that for fixed x , $p_d^+ \sim \sqrt{Q^2} \gg m_N$

$$\Delta^\mu \equiv p_1^\mu + p_2^\mu - p_d^\mu \equiv (\Delta^-, \Delta^+, \Delta_\perp) = (\Delta^-, 0, 0),$$

where

$$\begin{aligned} \Delta^- &= p_1^- + p_2^- - p_d^- = \frac{m_N^2 + k_\perp^2}{p_1^+} + \frac{m_N^2 + k_\perp^2}{p_2^+} - \frac{M_d^2}{p_d^+} \\ &= \frac{1}{p_d^+} \left[\frac{4(m_N^2 + k_\perp^2)}{\alpha_1(2 - \alpha_1)} - M_d^2 \right] = \frac{4}{p_d^+} \left[m_N^2 - \frac{M_d^2}{4} + k^2 \right]. \end{aligned}$$

In high Q^2 limit $\frac{\Delta^-}{2m_N} \ll 1$ - Small Parameter

$$\begin{aligned} \Gamma_d^\mu &= \Gamma_1 \gamma^\mu + \Gamma_2 \frac{(p_1 - p_2)^\mu}{2m_N} + \Gamma_3 \frac{\cancel{\Delta^\mu}}{2m_N} + \Gamma_4 \frac{(p_1 - p_2)^\mu \cancel{\Delta}}{4m_N^2} \\ &+ i\Gamma_5 \frac{1}{4m_N^3} \gamma_5 \epsilon^{\mu\nu\rho\gamma} (p_d)_\nu (p_1 - p_2)_\rho (\Delta)_\gamma + \Gamma_6 \frac{\cancel{\Delta^\mu \Delta}}{4m_N^2} \end{aligned}$$

Consider: $\epsilon^{\mu,+,\perp,-} p_{d,-} k_{\perp} \Delta_{+}$

Since: $p_{d,-} = \frac{1}{2} p_d^{+}$ and $\Delta_{+} = \frac{1}{2} \Delta^{-}$ then $p_d^{+} \Delta^{-} = p_d^{+} \frac{1}{p_d^{+}} \left[\frac{4(m_N^2 + k_{\perp}^2)}{\alpha_1(2-\alpha_1)} - M_d^2 \right] = \left[\frac{4(m_N^2 + k_{\perp}^2)}{\alpha_1(2-\alpha_1)} - M_d^2 \right]$

$\epsilon^{\mu,+,\perp,-} p_{d,-} k_{\perp} \Delta_{+} = \frac{1}{4} \epsilon^{\mu,+,\perp,-} p_d^{+} k_{\perp} \Delta^{-}$ **Leading Order!**

$$\Gamma_d^{\mu} = \Gamma_1 \gamma^{\mu} + \Gamma_2 \frac{(p_1 - p_2)^{\mu}}{2m_N} + \cancel{\Gamma_3 \frac{\Delta^{\mu}}{2m_N}} + \Gamma_4 \frac{(p_1 - p_2)^{\mu} \cancel{\Delta}}{4m_N^2} + i\Gamma_5 \frac{1}{4m_N^3} \gamma_5 \epsilon^{\mu\nu\rho\gamma} (p_d)_{\nu} (p_1 - p_2)_{\rho} (\Delta)_{\gamma} + \Gamma_6 \frac{\cancel{\Delta^{\mu} \Delta}}{4m_N^2}$$

$$\psi_d^{\lambda_d}(\alpha_i, k_{\perp}) = - \sum_{\lambda_2, \lambda_1, \lambda_1'} \bar{u}(-k, \lambda_2) \left\{ \Gamma_1 \gamma^{\mu} + \Gamma_2 \frac{\tilde{k}^{\mu}}{m_N} + \sum_{i=1}^2 i\Gamma_5 \frac{1}{8m_N^3} \epsilon^{\mu+i-} p_d'^{+} k_i \Delta'^{-} \right\} \gamma_5 \frac{\epsilon_{\lambda_1, \lambda_1'}}{\sqrt{2}} u(k, \lambda_1') s_{\mu}^{\lambda_d}$$

where $\tilde{k}^{\mu} = (0, k_z, k_{\perp})$

$$\psi_d^{\lambda_d}(\alpha_i, k_\perp) = - \sum_{\lambda_2, \lambda_1, \lambda'_1} \bar{u}(-k, \lambda_2) \left\{ \Gamma_1 \gamma^\mu + \Gamma_2 \frac{\tilde{k}^\mu}{m_N} + \sum_{i=1}^2 i \Gamma_5 \frac{1}{8m_N^3} \epsilon^{\mu+i-} p_d'^+ k_i \Delta'^- \right\} \gamma_5 \frac{\epsilon_{\lambda_1, \lambda'_1}}{\sqrt{2}} u(k, \lambda'_1) s_\mu^{\lambda_d}$$

$$\begin{aligned} \psi_d^{\lambda_d}(\alpha_1, k_t, \lambda_1, \lambda_2) = & \sum_{\lambda'_1} \phi_{\lambda_2}^\dagger \sqrt{E_k} \left[\frac{U(k)}{\sqrt{4\pi}} \sigma s_d^{\lambda_d} - \frac{W(k)}{\sqrt{4\pi}\sqrt{2}} \left(\frac{3(\sigma \mathbf{k})(\mathbf{k} s_d^\lambda)}{k^2} - \sigma s_d^\lambda \right) + \right. \\ & \left. (-1)^{\frac{1+\lambda_d}{2}} P(k) Y_1^{\lambda_d}(\theta, \phi) \delta^{1, |\lambda_d|} \right] \frac{\epsilon_{\lambda_1, \lambda'_1}}{\sqrt{2}} \phi_{\lambda'_1} \end{aligned}$$

$$U(k) = \frac{2\sqrt{4\pi}\sqrt{E_k}}{3} \left[\Gamma_1 \left(2 + \frac{m_N}{E_k} \right) + \Gamma_2 \frac{k^2}{m_N E_k} \right]$$

$$W(k) = \frac{2\sqrt{4\pi}\sqrt{2E_k}}{3} \left[\Gamma_1 \left(1 - \frac{m_N}{E_k} \right) - \Gamma_2 \frac{k^2}{m_N E_k} \right]$$

Where: $Y_1^\pm(\theta, \phi) = \mp i \sqrt{\frac{3}{4\pi}} \sum_{i=1}^2 \frac{(k \times s_d^{\pm 1})_z}{k}$

$$P(k) = \sqrt{4\pi} \frac{\Gamma_5(k) \sqrt{E_k}}{\sqrt{3}} \frac{k^3}{m_N^3}$$

fully relativistic: in addition to $\frac{k^{l=1}}{m_N}$ term
has additional $\frac{k^2}{m_N^2}$ term

Light Front Density Matrix and Momentum Distribution

$$\psi_d^{\lambda_d}(\alpha_1, k_t, \lambda_1, \lambda_2) = \sum_{\lambda'_1} \phi_{\lambda'_1}^\dagger \sqrt{E_k} \left[\frac{U(k)}{\sqrt{4\pi}} \sigma_{\mathbf{s}_d}^{\lambda_d} - \frac{W(k)}{\sqrt{4\pi}\sqrt{2}} \left(\frac{3(\sigma \mathbf{k})(\mathbf{k} \mathbf{s}_d^{\lambda_d})}{k^2} - \sigma_{\mathbf{s}_d}^{\lambda_d} \right) + (-1)^{\frac{1+\lambda_d}{2}} P(k) Y_1^{\lambda_d}(\theta, \phi) \delta^{1,|\lambda_d|} \right] \frac{\epsilon_{\lambda_1, \lambda'_1}}{\sqrt{2}} \phi_{\lambda'_1}$$

$$\rho_d(\alpha, k_\perp) = \frac{n_d(k, k_\perp)}{2-\alpha}$$

$$n_d(k, k_\perp) = \frac{1}{3} \sum_{\lambda_d=-1}^1 | \psi_d^{\lambda_d}(\alpha, k_\perp) |^2 = \frac{1}{4\pi} \left(U(k)^2 + W(k)^2 + \frac{k_\perp^2}{k^2} P^2(k) \right)$$

Baryonic and Momentum Sum Rules $\int \rho_d(\alpha, k_\perp) \frac{d\alpha}{\alpha} = 1$ and $\int \alpha \rho_d(\alpha, k_\perp) \frac{d\alpha}{\alpha} = 1$

$$\int (U(k)^2 + W(k)^2 + \frac{2}{3} P^2(k)) k^2 dk = 1.$$

Non-Nucleonic Components and the New Structure

$$n_d(k, k_{\perp}) = \frac{1}{3} \sum_{\lambda_d=-1}^1 |\psi_d^{\lambda_d}(\alpha, k_{\perp})|^2 = \frac{1}{4\pi} \left(U(k)^2 + W(k)^2 + \frac{k_{\perp}^2}{k^2} P^2(k) \right)$$

- Momentum distribution depends on k_{\perp} separately
- *This is impossible for non-relativistic quantum mechanics of the deuteron since in this case the potential of the interaction is real (no inelasticities) and the solution of Lippmann-Schwinger (or Schroedinger) equation for partial S- and D-waves satisfies "angular condition", according to which the momentum distribution in unpolarized deuteron depends on the magnitude of relative momentum only.*
- On the other hand, in the relativistic domain the definition of the interaction potential is not straightforward to allow to use quantum-mechanical arguments in claiming that momentum distribution should satisfy the angular condition (i.e. depends on magnitude of k only).

- However, for the Light-Front, there is a remarkable theorem by Frankfurt and Strikman which states that if **one considers only pn component in the deuteron**, then for most acceptable forms of NN potential – constructed from elastic pn → pn scattering, the angular condition should be satisfied also for LF momentum distribution.

$$T_{NN}(\alpha_i, k_{i\perp}, \alpha_f, k_{f,\perp}) \equiv T_{NN}(k_{i,z}, k_{i\perp}, k_{f,z}, k_{f,\perp}) = V(k_{i,z}, k_{i\perp}, k_{f,z}, k_{f,\perp}) + \int V(k_{i,z}, k_{i\perp}, k_{m,z}, k_{m,\perp}) \times \frac{d^3 k_m}{(2\pi)^3 \sqrt{m^2 + k_m^2}} \frac{T_{NN}(k_{m,z}, k_{m,\perp}, k_{f,z}, k_{f,\perp})}{4(k_m^2 - k_f^2)}$$

- The realization of the angular condition for relativistic case will require that light-front potential to satisfy a condition

$$V(k_{i,z}, k_{i\perp}, k_{m,z}, k_{m,\perp}) = V(\vec{k}_i^2, (\vec{k}_m - \vec{k}_i)^2)$$

- Lorentz invariance for on-shell NN amplitude requires

$$T_{NN}^{on\ shell}(k_{i,z}, k_{i\perp}, k_{m,z}, k_{m,\perp}) = T_{NN}^{on\ shell}(\vec{k}_i^2, (\vec{k}_m - \vec{k}_i)^2)$$

- Existence of the Born term indicates that

$$T_{NN}^{on\ shell}(\vec{k}_i^2, (\vec{k}_m - \vec{k}_i)^2) = V_{NN}^{on\ shell}(\vec{k}_i^2, (\vec{k}_m - \vec{k}_i)^2) + \int V_{NN}(k_{i,z}, k_{i\perp}, k_{m,z}, k_{m,\perp}) \times \frac{d^3 k_m}{(2\pi)^3 \sqrt{m^2 + k_m^2}} \frac{T_{NN}(k_{m,z}, k_{m\perp}, k_{f,z}, k_{f,\perp})}{4(k_m^2 - k_f^2)}$$

- Iterating the equation around the on-shell kinematic point.

$$T_{NN}(\alpha_i, k_{i\perp}, \alpha_f, k_{f,\perp}) \equiv T_{NN}(k_{i,z}, k_{i\perp}, k_{f,z}, k_{f,\perp}) = V(k_{i,z}, k_{i\perp}, k_{f,z}, k_{f,\perp}) + \int V(k_{i,z}, k_{i\perp}, k_{m,z}, k_{m,\perp}) \times \frac{d^3 k_m}{(2\pi)^3 \sqrt{m^2 + k_m^2}} \frac{T_{NN}(k_{m,z}, k_{m\perp}, k_{f,z}, k_{f,\perp})}{4(k_m^2 - k_f^2)}$$

- will result in:

$$T_{NN}(k_{i,z}, k_{i\perp}, k_{m,z}, k_{m,\perp}) = T_{NN}(\vec{k}_i^2, (\vec{k}_m - \vec{k}_i)^2)$$

$$V_{NN}(k_{i,z}, k_{i\perp}, k_{m,z}, k_{m,\perp}) = V_{NN}(\vec{k}_i^2, (\vec{k}_m - \vec{k}_i)^2) \quad \text{for the general case}$$

- V_{NN} – analytic function of angular momentum and it does not diverge exponentially in the complex-angular momentum space it was shown that also for the off-shell case

- For Non-nucleonic components no such iteration can be done

$$T_{NN}(k_{i,z}, k_{i,\perp}, k_{f,z}, k_{f,\perp}) = \int V_{NN^*}(k_{i,z}, k_{i,\perp}, k_{m,z}, k_{m,\perp}) \frac{d^3 k_m}{(2\pi)^3 \sqrt{m_m^2 + k_m^2}} \frac{T_{N^*N}(k_{m,z}, k_{m,\perp}, k_{f,z}, k_{f,\perp})}{4(k_m^2 - k_f^2 + m_m^2 - m_N^2)}$$

- transition amplitudes such as $T_{\Delta\Delta\rightarrow NN}$, $T_{N^*,N\rightarrow NN}$ or $T_{N^c,N^c\rightarrow NN}$ where N^cN^c represents a hidden color component in the deuteron could not be described with any combination of interaction potentials that satisfies angular condition

- if Γ_5 term is not zero then it should originate from non-nucleonic component in the deuteron.

- Our prediction is that the observation of LF momentum distribution depending on the center of mass k and k_\perp separately will indicate the presence of non-nucleonic component in the deuteron

Estimate of the effect

$$n_d(k, k_{\perp}) = \frac{1}{3} \sum_{\lambda_d=-1}^1 |\psi_d^{\lambda_d}(\alpha, k_{\perp})|^2 = \frac{1}{4\pi} \left(U(k)^2 + W(k)^2 + \frac{k_{\perp}^2}{k^2} P^2(k) \right)$$

$$P(k) = \sqrt{4\pi} \frac{\Gamma_5(k) \sqrt{E_k}}{\sqrt{3}} \frac{k^3}{m_N^3}$$

Hidden Color Component

$$\Gamma_5(k) = \frac{A}{(1 + \frac{k^2}{0.71})^2}$$

A is estimated by assuming 1% contribution to the total normalization.

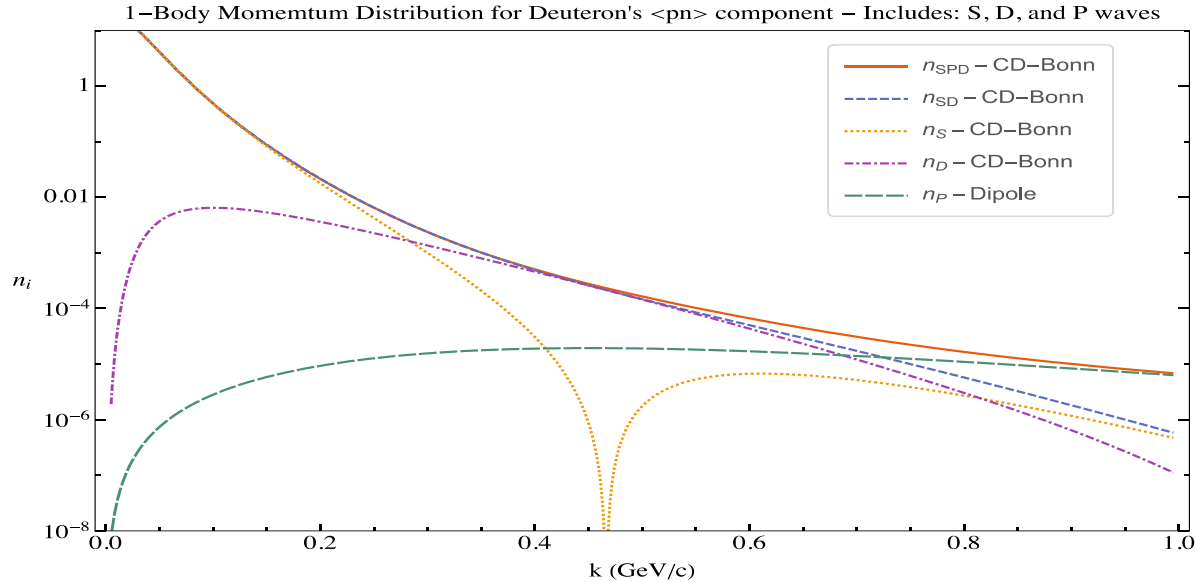

Estimate of the effect

$$n_d(k, k_\perp) = \frac{1}{3} \sum_{\lambda_d=-1}^1 |\psi_d^{\lambda_d}(\alpha, k_\perp)|^2 = \frac{1}{4\pi} \left(U(k)^2 + W(k)^2 + \frac{k_\perp^2}{k^2} P^2(k) \right)$$

$$P(k) = \sqrt{4\pi} \frac{\Gamma_5(k) \sqrt{E_k}}{\sqrt{3}} \frac{k^3}{m_N^3}$$

$$\Gamma_5(k) = \frac{A}{(1 + \frac{k^2}{0.71})^2}$$

A is estimated by assuming 1% contribution to the total normalization.

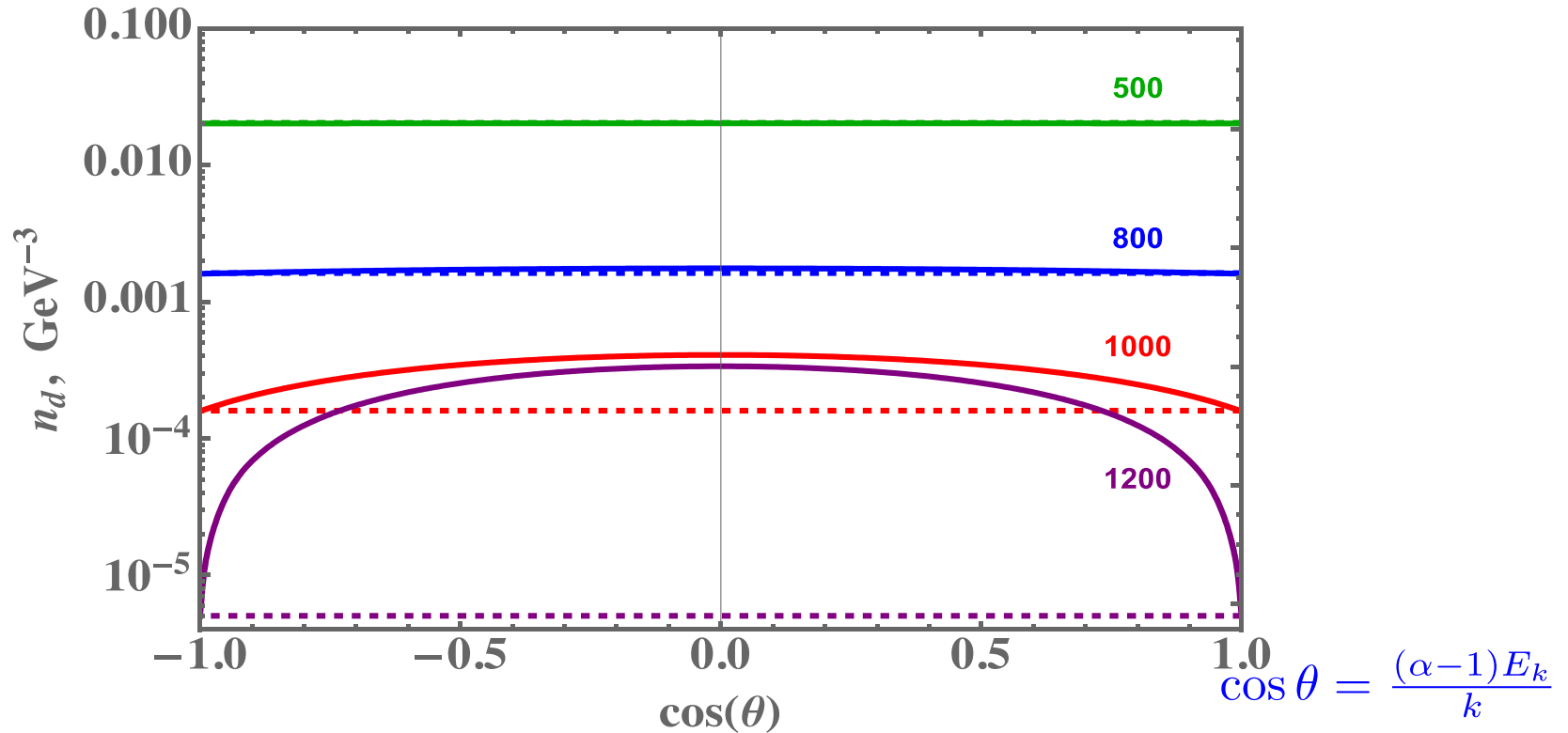

Estimate of the effect

$$A_T = \frac{n_d^{\lambda_d=1}(k, k_\perp) + n_d^{\lambda_d=-1}(k, k_\perp) - 2n_d^{\lambda_d=0}(k, k_\perp)}{n_d(k, k_\perp)}$$

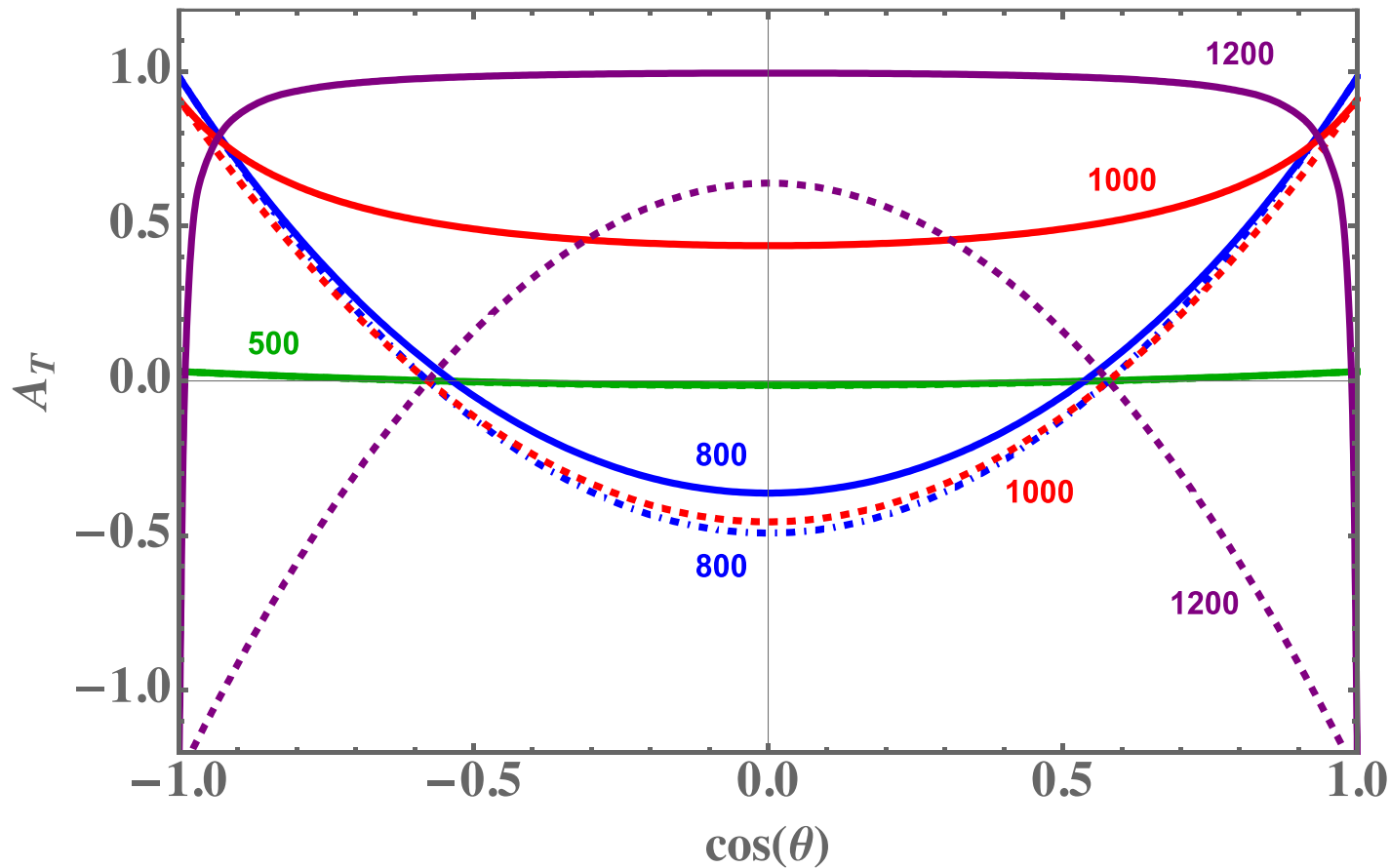

$$\cos \theta = \frac{(\alpha-1)E_k}{k}$$

Possibility of Experimental Verification

Considering reaction: $e + d \rightarrow e' + p_f + n$

$$|p_i| = |p_f - q| \gtrsim 800 \text{ MeV}/c$$

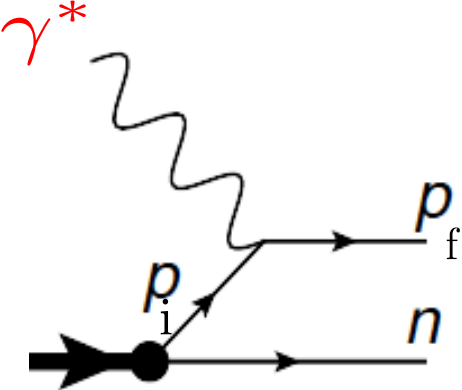

PAC-36, 2010 (experimental proposal, W. Boeglin, PI)

- E12-10-003 ($p_m \square 300 \text{ MeV}$): “Deuteron Electro-Disintegration at Very High Missing Momentum”

Rating: B+

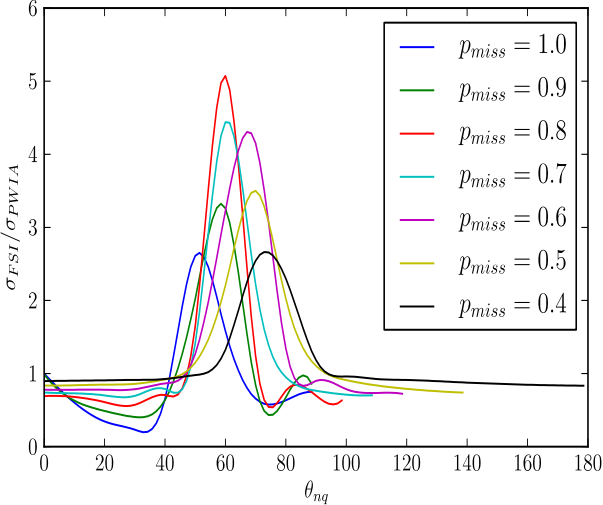

data are essential to constrain further theory developments. Overall the experiment was viewed very highly; the lower rating simply reflects the likelihood that the data will not reveal any particular surprise and that their impact may thus be limited to experts in the field.

Possibility of Experimental Verification

Considering reaction: $e + d \rightarrow e' + p_f + n$

$$|p_i| = |p_f - q| \gtrsim 800 \text{ MeV}/c$$

3-days of commissioning measurement,

JLab experiment $Q^2 = 4 \text{ GeV}^2$

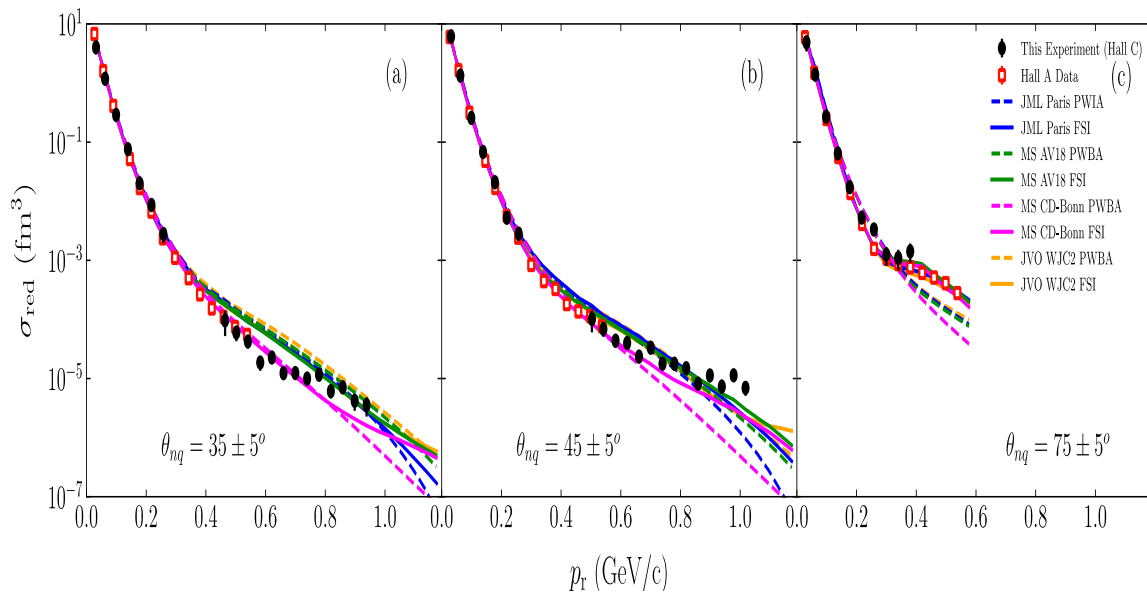
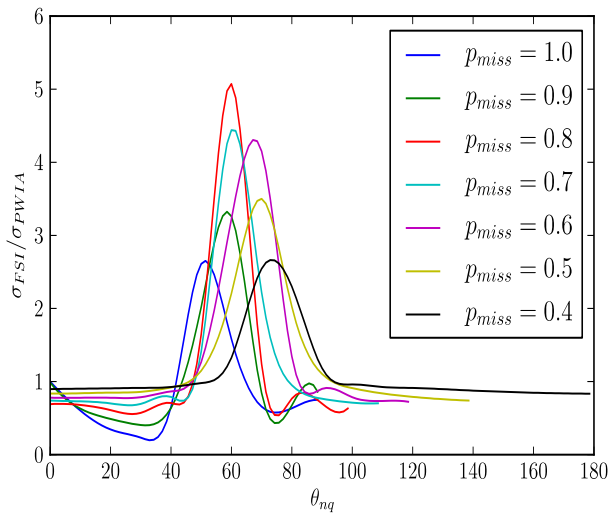
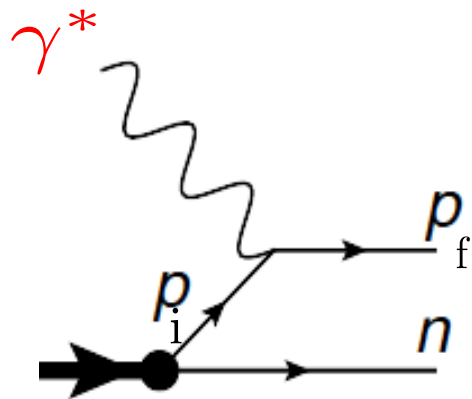

1-Body Momentum Distribution for Deuteron's $\langle pn \rangle$ component – Includes: S, D, and P waves

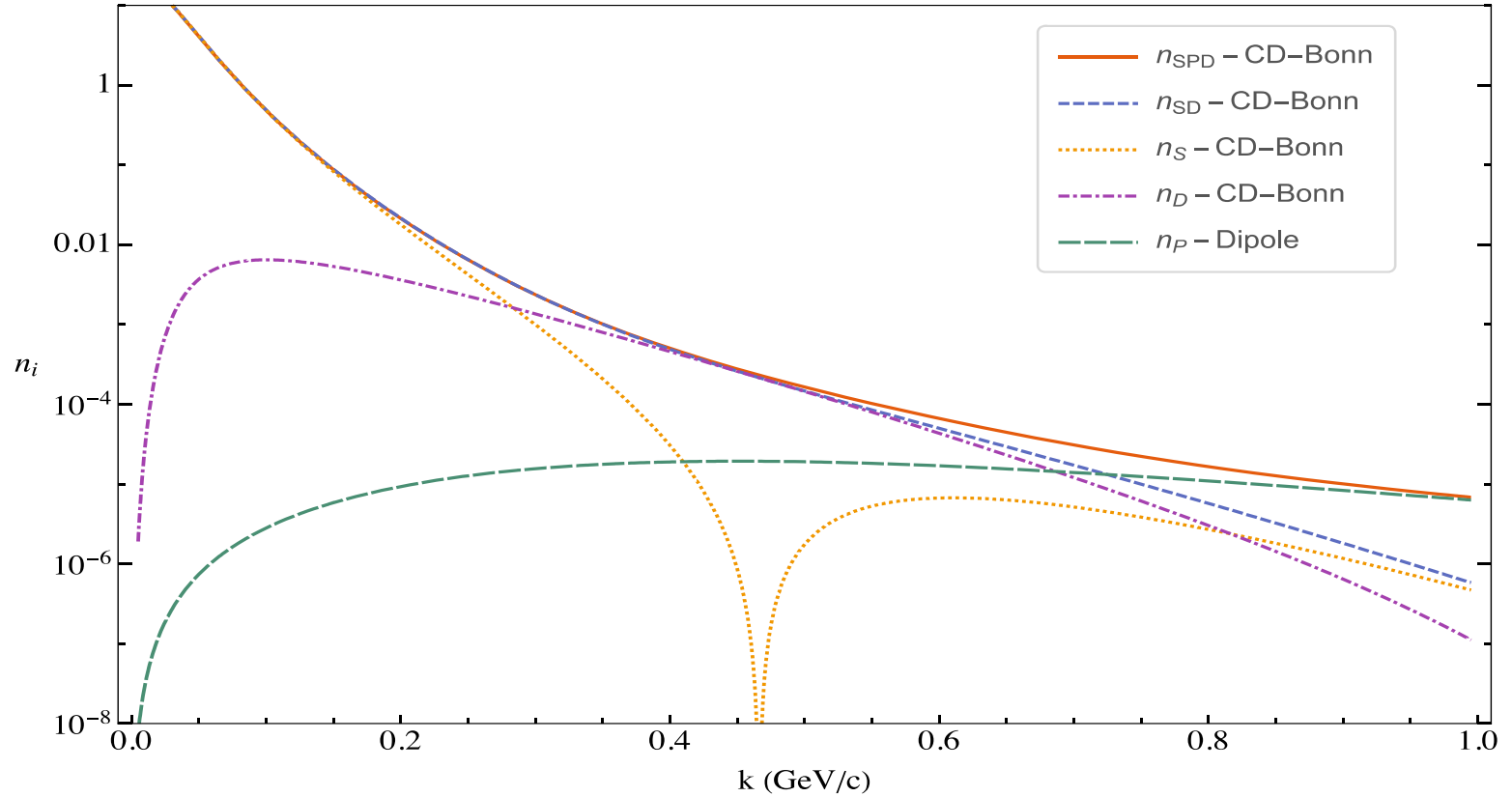

Possibility of Experimental Verification

Considering reaction: $e + d \rightarrow e' + p_f + n$

$$|p_i| = |p_f - q| \gtrsim 800 \text{ MeV}/c$$

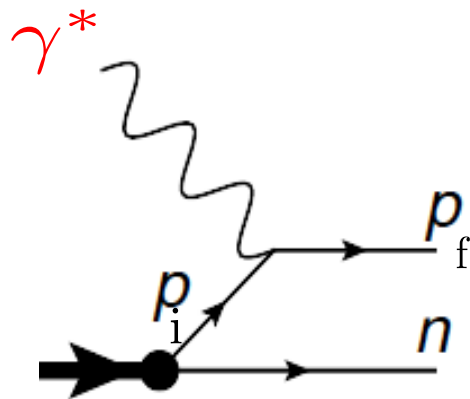

PAC-49, 2021

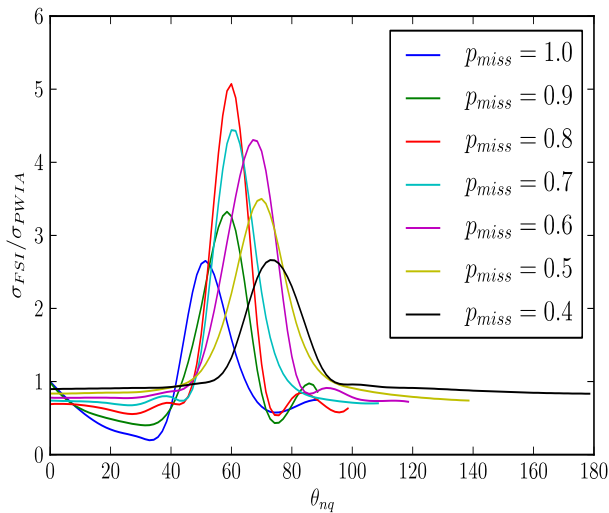

PAC 49 SUMMARY OF JEOPARDY RECOMMENDATIONS

Number	Contact Person	Title	Hall	Previously Approved Days	Days Already Rec'd	Days Awarded	PAC Decision
E12-09-011	Tanja Horn	Studies of the L-T Separated Kaon Electroproduction Cross Section from 5-11 GeV	C	40	32	8	Remain active
E12-10-003	W. Boeglin	Deuteron Electro-Disintegration at Very High Missing Momentum	C	21	3	18	Upgrade Rating to A-

1) Is there any new information that would affect the scientific importance or impact of the Experiment since it was originally proposed?

PAC 36 graded the proposal with B+ because, even though the physics motivation was viewed highly, the foreseen impact of the result was judged to be limited. The results of the three days commissioning in April 2018, published in Physical Review Letters 125, 262501 (2020), exhibit an unexpected behavior when compared with theoretical calculations. Therefore, the expected impact of future data has increased.

Outlook on Experimental Verification of the Effect

- We know where to look for short range phenomena in the deuteron suppressing Long Range Effects
- If angular dependence is found it will motivate new area of research
 - a: modeling non-nucleonic components in the deuteron,
 - b: understanding their origin and nature
 - c: evaluating parameters that can be used for Equation of State of high density Nuclear Matter
- If no angular dependence is found but high momentum probability is large,
 - a: nucleonic degrees persist at very high density fluctuations
 - b: vacuum fluctuations enhance the high momentum component in the deuteron

Probing the “Size” of the NN-Core

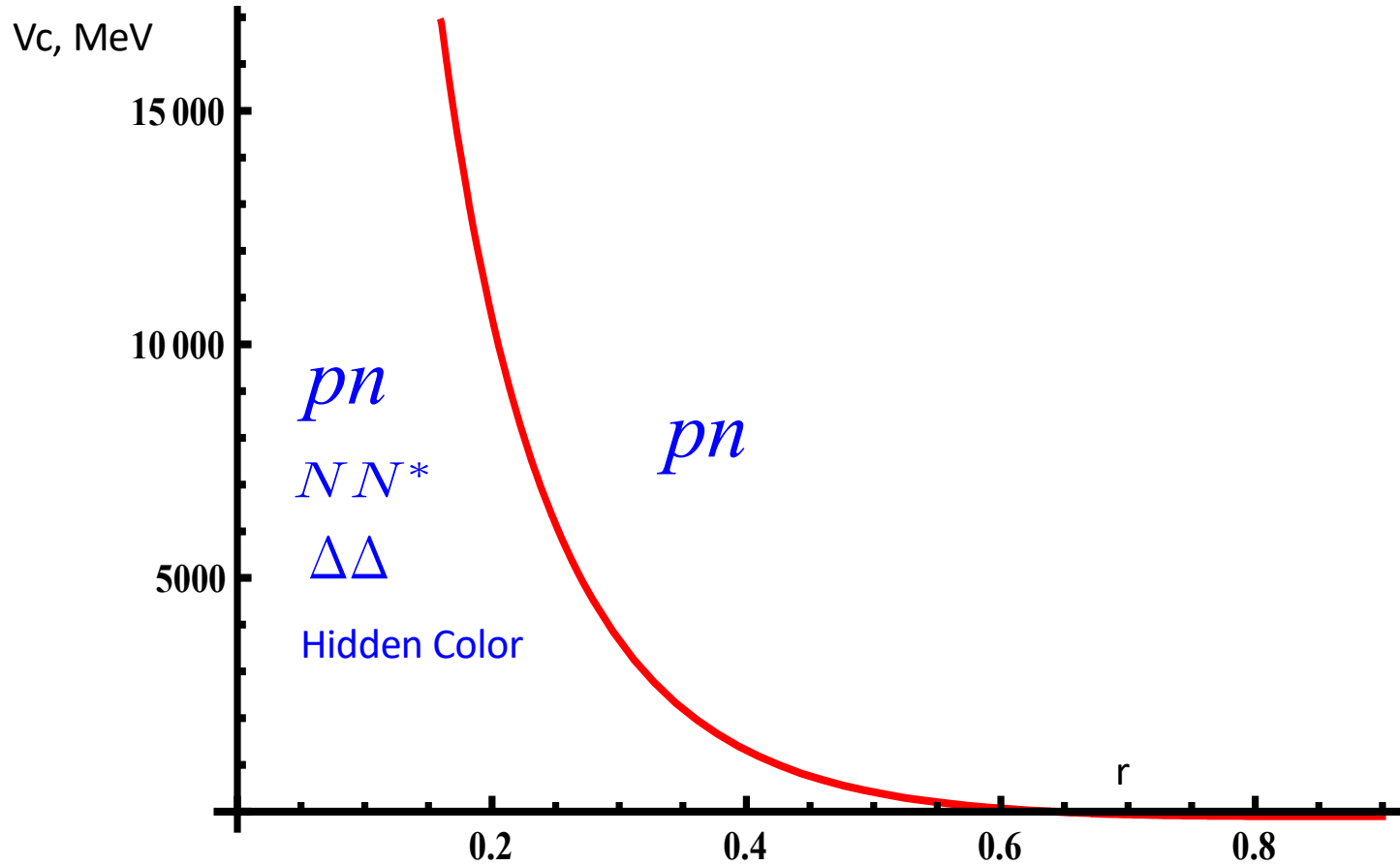

Probing the “Size” of the NN-Core

Quantum Mechanics of the Repulsive Core

Consider the S-state

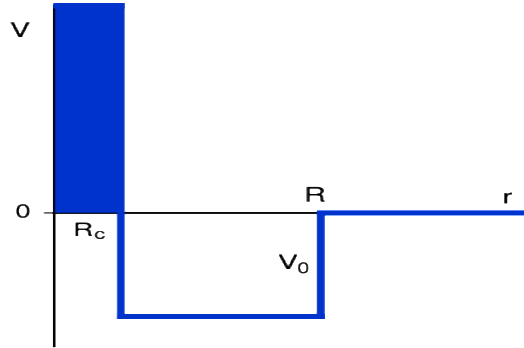

$$R_S(r) = A \sin(k_0(R - R_C)) \text{ for } R_c \leq r \leq R, \text{ where } k_0 = \sqrt{M(|E_b| + V_0)}$$

$$R_S(r) = B e^{-\kappa r}, \text{ for } r > R, \text{ where } \kappa = \sqrt{M|E_b|}$$

$$n(p) = |u(p)|^2, \text{ where } u(p) = \frac{2}{\sqrt{2\pi}} \int j_0(pr) R_s(r) r dr.$$

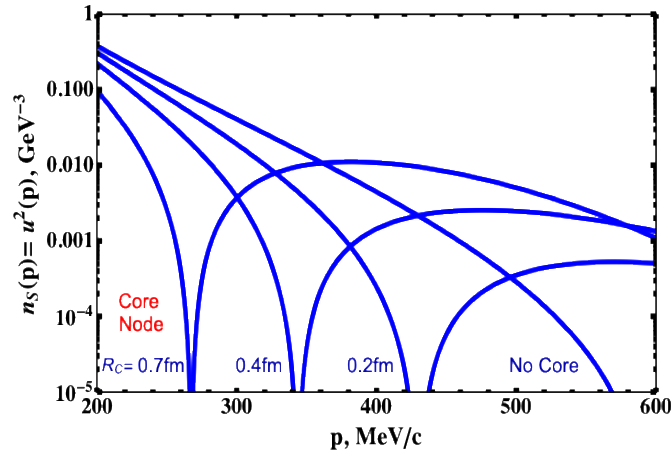
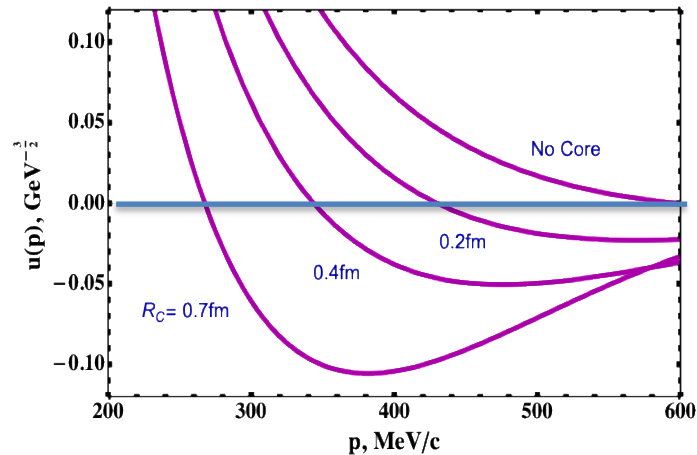

Probing the 3S_1 – state in the deuteron

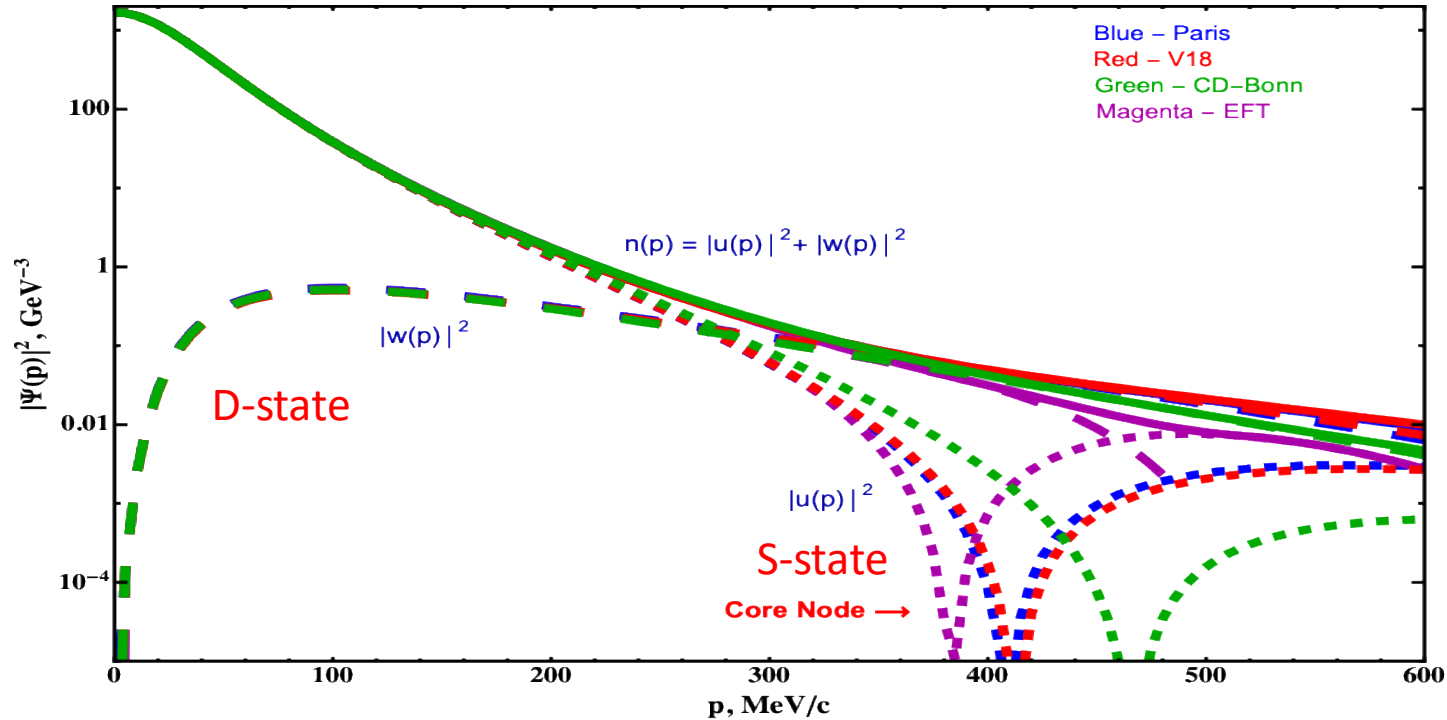

The Nature choose to hide the node

How to suppress D-wave contribution ?

Probing the 3S_1 – state in the deuteron

Considering reaction: $e + d \rightarrow e' + p_f + n$ *For tensor polarized deuteron*

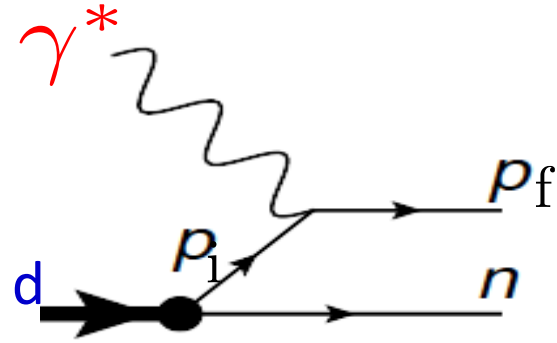

$$\rho_{unp}(p) = n(p) = |u(p)|^2 + |w(p)|^2.$$

$$\rho_{20}(p, \theta_N) \equiv \frac{|\psi_d^1|^2 + |\psi_d^{-1}|^2 - 2|\psi_d^0|^2}{3} = \frac{3 \cos^2(\theta_N) - 1}{2} [2\sqrt{2}u(p)w(p) - w^2(p)]$$

$$\rho_{node}(p) = \rho_{unp}(p) + \frac{2\rho_{20}}{3 \cos^2(\theta_N) - 1} = u^2(p) + 2\sqrt{2}u(p)w(p),$$

$$A_{node}(p) \equiv \frac{\rho_{node}(p)}{\rho_{unp}(p)} = 1 + \frac{2A_{zz}(p, \theta_N)}{3 \cos^2(\theta_N) - 1} = \frac{u^2(p) + 2\sqrt{2}u(p)w(p)}{u(p)^2 + w(p)^2},$$

Probing the 3S_1 – state in the deuteron

Considering reaction: $e + d \rightarrow e' + p_f + n$

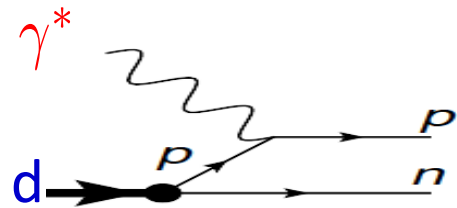

$$A_{node}(p) = \frac{u^2(p) + 2\sqrt{2}u(p)w(p)}{u(p)^2 + w(p)^2}$$

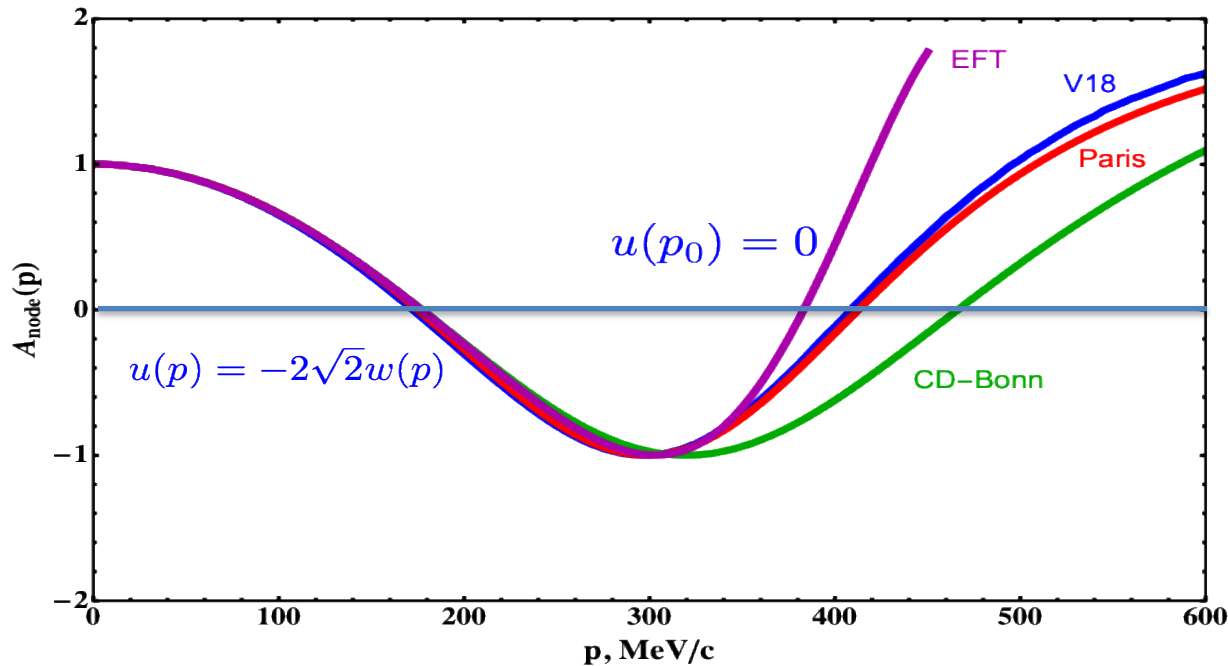

Probing the 3S_1 – state in the deuteron

Considering reaction: $e + d \rightarrow e' + p_f + n$

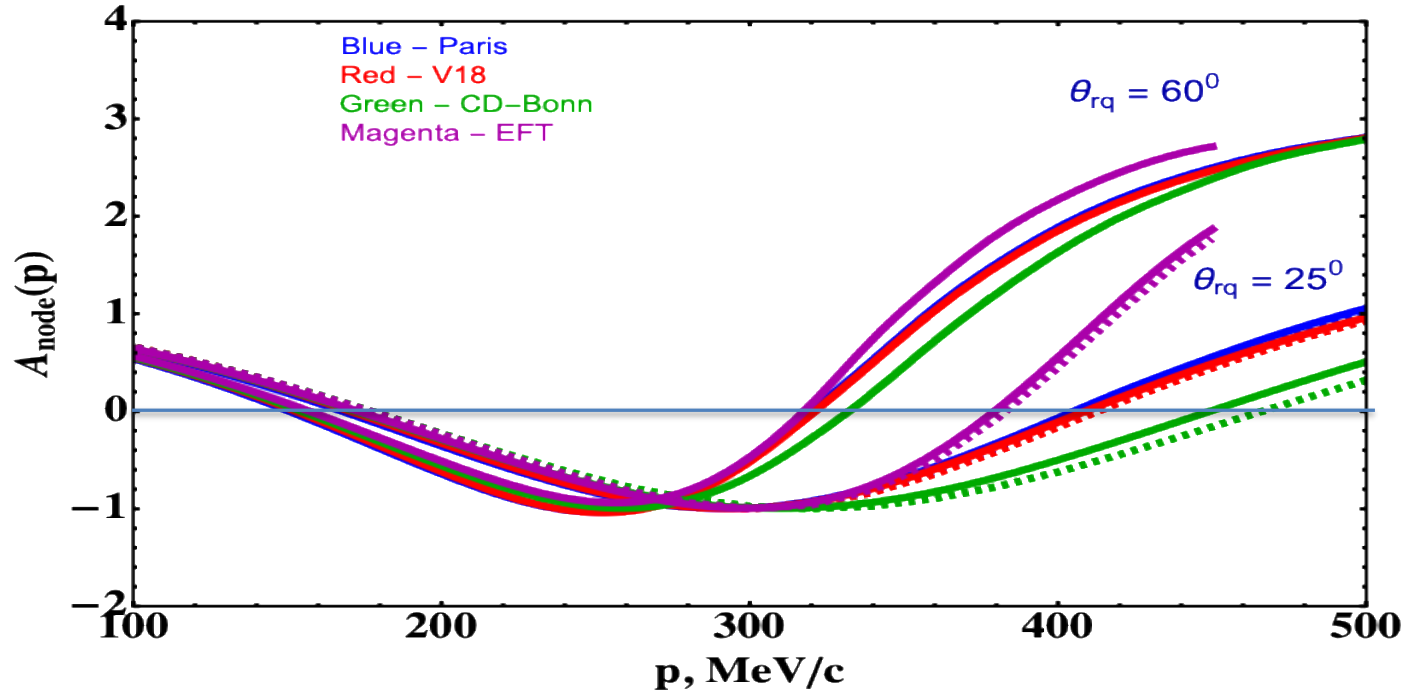
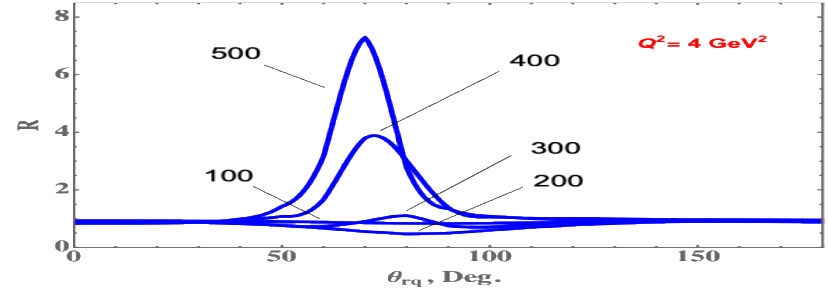
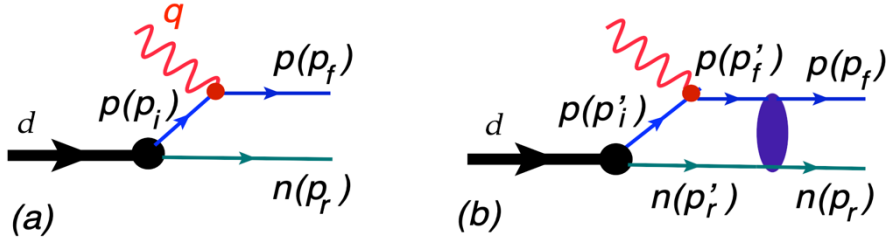

New Sum Rules for NN-Potentials

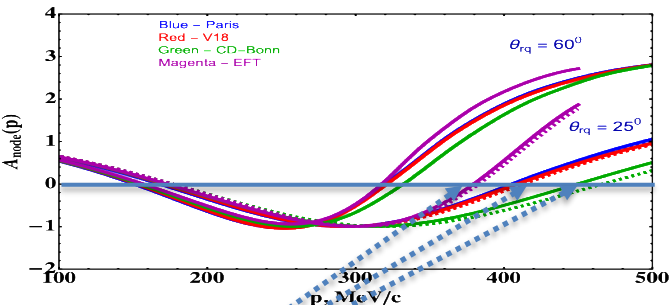

p_0

What if the p_0 value is measured?

$$\left[-\frac{\nabla^2}{m} + V(r) \right] \psi(r) = E_b \psi(r)$$

$$V(r) = V_c(r) + S_{12}V_T(r) \quad \hat{S}_{12} = 3(\vec{\sigma}_p \hat{r})(\vec{\sigma}_n \hat{r}) - \vec{\sigma}_p \vec{\sigma}_n$$

$$\Phi_l^{1,m_d}(\theta, \phi) = \sum_{m_l=-l}^l C_{l,m_l;1,m_s}^{1,m_d} Y_l^m(\theta, \phi) | S_{1,m_s} \rangle$$

$$\frac{d^2}{dr^2} u_l(r) + m \left(E_b - \frac{l(l+1)}{mr^2} - V_C(r) \right) u_l(r) - mV_T(r) \sum_{l'=0,2} S_{1,l,l'} u_{l'}(r) = 0$$

$$S_{1,l',l} = \int (\Phi_l^{1,m_d} \hat{S}_{12} \Phi_{l'}^{1,m_d}) d\Omega. \quad \text{Racha - Algebra}$$

$$\frac{d^2}{dr^2} u_0(r) + m (E_b - V_C(r)) u_0(r) - \sqrt{8}mV_T(r)u_2(r) = 0$$

Eisenberg & Greiner

Microscopic Theory of Nucleus, 1972

$$\frac{d^2}{dr^2} u_2(r) + m \left(E_b - \frac{6}{mr^2} - V_C(r) + 2V_T(r) \right) u_2(r) - \sqrt{8}mV_T(r)u_0(r) = 0.$$

New Sum Rules for NN-Potentials

$$(E_b - \frac{k^2}{m})u(k) = \int V_C(|\vec{k} - \vec{p}|)u(p) \frac{d^3 p}{(2\pi)^3} + \sqrt{8} \int V_T(|\vec{k} - \vec{p}|)w(p)P_2(\cos\theta_p) \frac{d^3 p}{(2\pi)^3}.$$

At $k = p_0$

Momentum Sum Rule

$$\int V_C(|\vec{p}_0 - \vec{p}|)u(p) \frac{d^3 p}{(2\pi)^3} + \sqrt{8} \int V_T(|\vec{p}_0 - \vec{p}|)w(p)P_2(\cos\theta_p) \frac{d^3 p}{(2\pi)^3} = 0$$

Sum Rule in Coordinate Space

$$\int [V_C(r)u(r) + \sqrt{8}V_T(r)w(r)] \sin(p_0 r) dr = 0$$

Summary

- Currently there is an unprecedented opportunity to conduct direct exploration of the structure and dynamics of the nuclear core
- These are delicate and time consuming experiments with the potential to make breakthroughs in several areas like: (i) Relativistic domain of nuclear physics, (ii) the role of the non-nucleonic components in nuclear forces, (iii) transition to QCD degrees of freedom, (iv) possibility of observation of hidden color degrees of freedom, etc
- I missed here the physics of superfast quarks that complements the nuclear core studies with direct application of QCD approaches in theoretical interpretation

“Unreasonable” Persistence of Nucleons

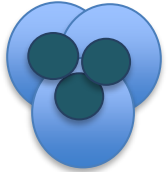
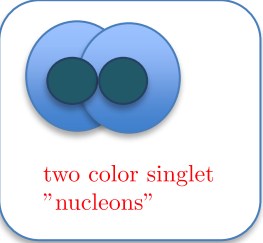
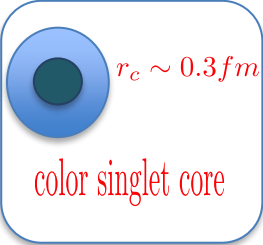
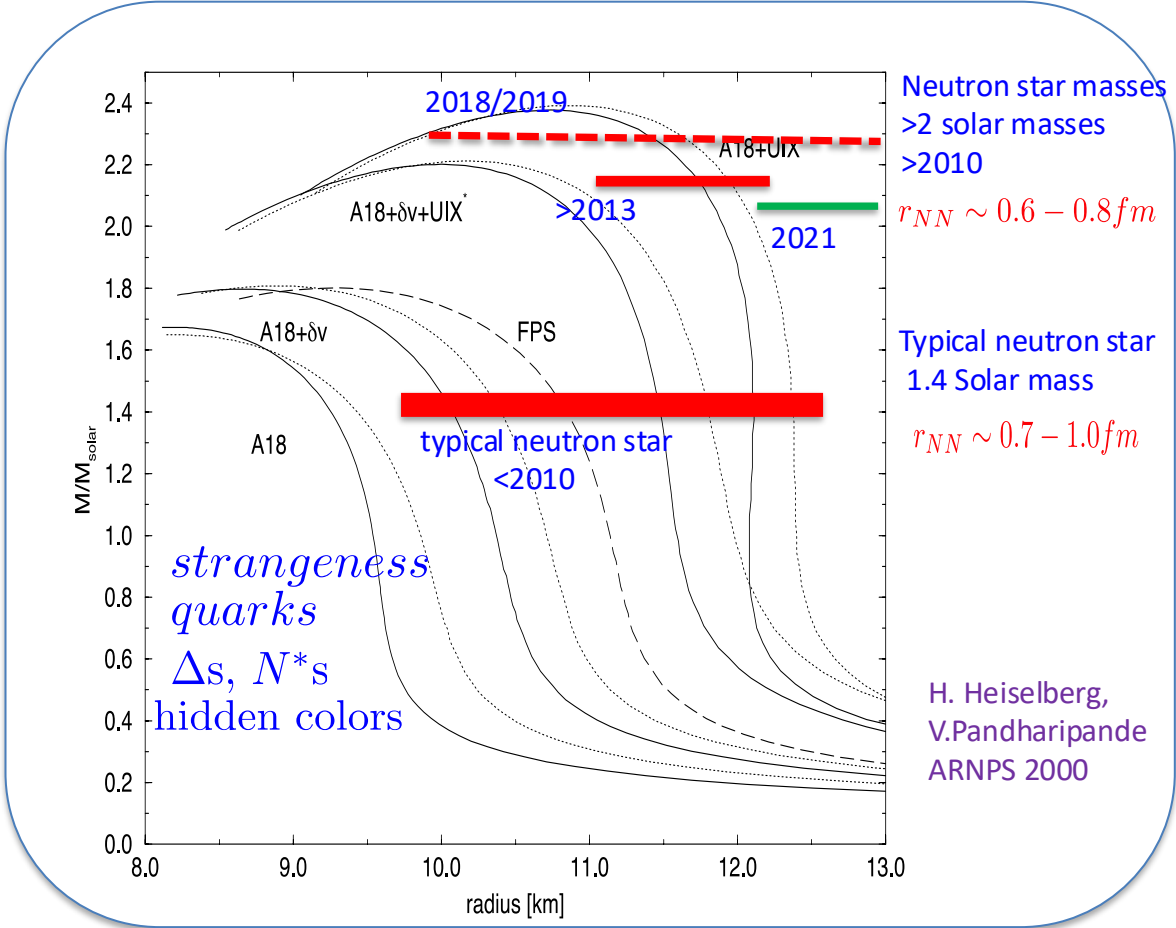

three color singlet

"baryons"