

The Nucleons Go Two By Two: Correlations in Nuclei

Lawrence Weinstein

Old Dominion University

- Independent Nucleons
- Correlated Nucleons (SRC)
- Scale Separation
- Short Range NN Interaction
- Summary

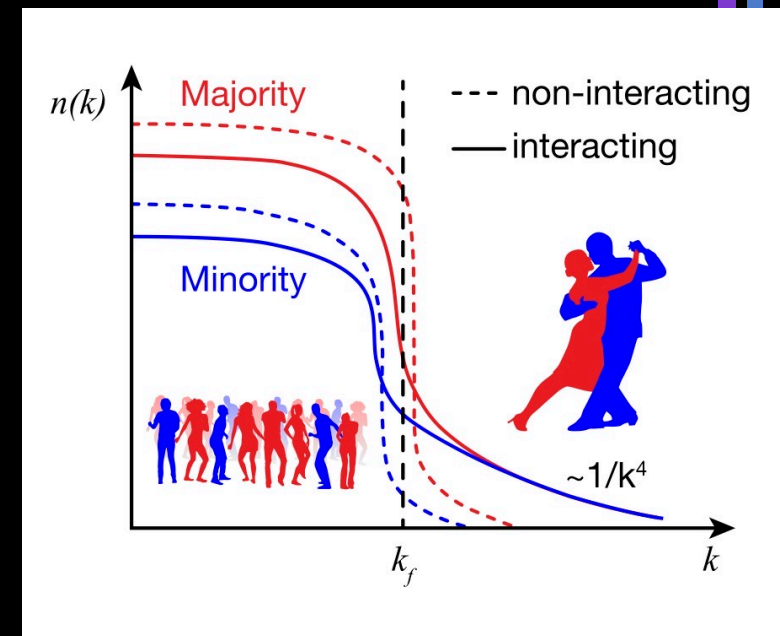

ODU, MIT, Tel Aviv, JLab, GWU ...

Mean Field measurement: (e,e'p)

Cross section (mostly) factorizes:

$$\frac{d\sigma}{dE_e d\Omega_e dT_p d\Omega_p} = K S(\vec{p}_{miss}, E_{miss}) \frac{d\sigma^{free}}{d\Omega}$$

$$E_{miss} = \nu - T_p - T_{A-1}$$

$$\vec{p}_{miss} = \vec{q} - \vec{p}_p$$

complicated by nucleon rescattering

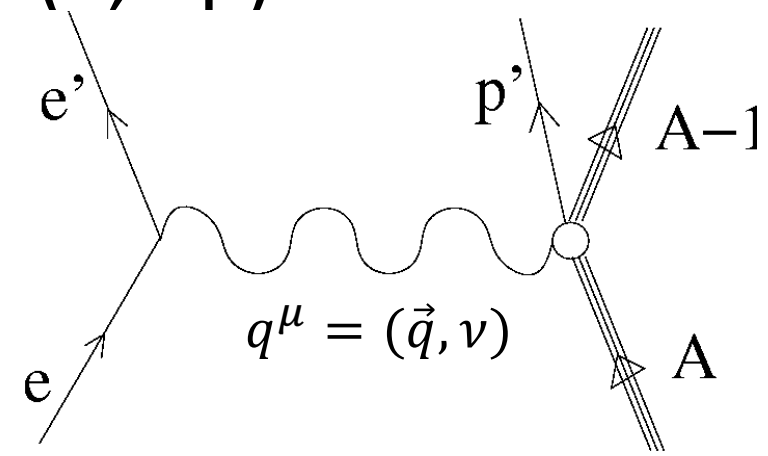

O(e,e'p)

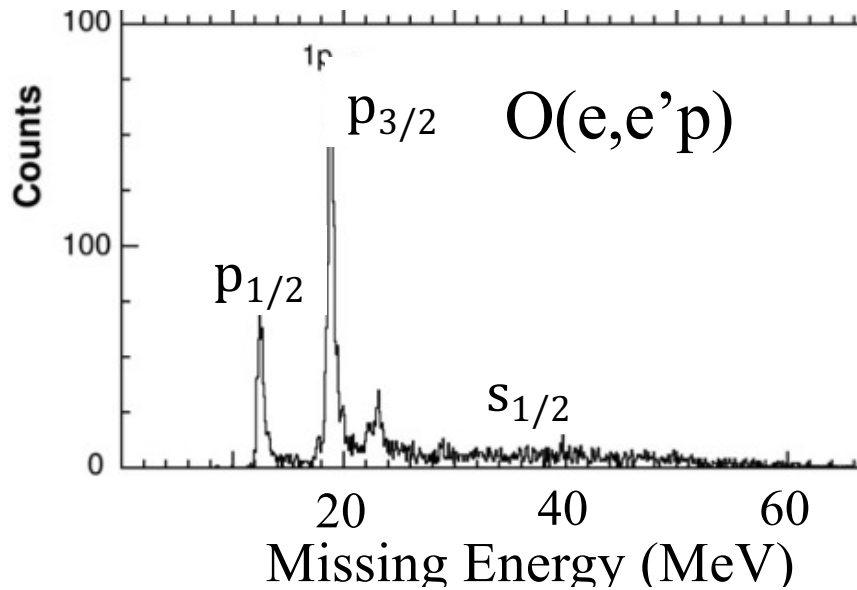

Fissum et al, PRC 70, 034606 (2003)

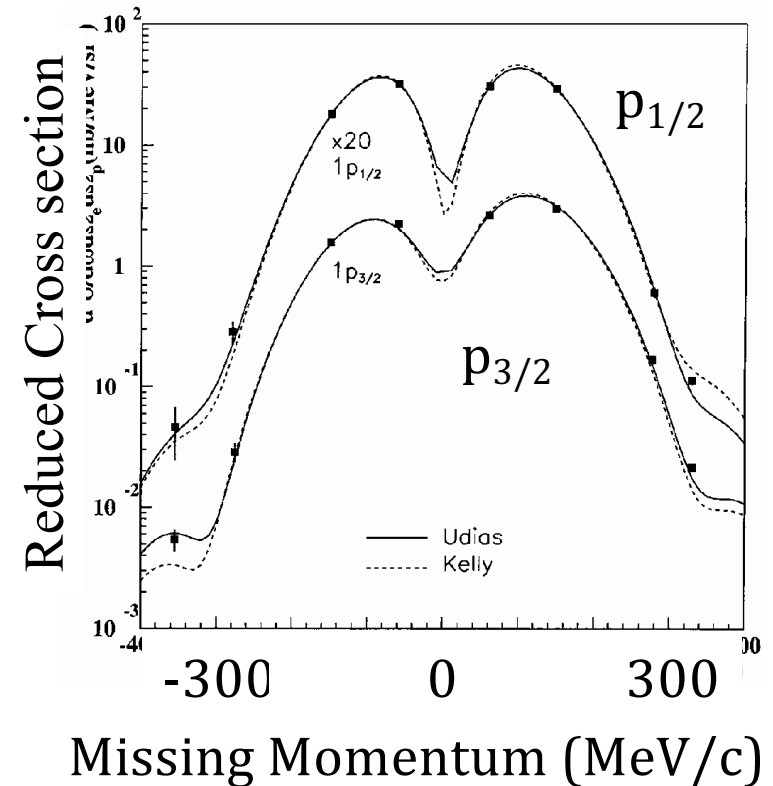

Mean field is not enough

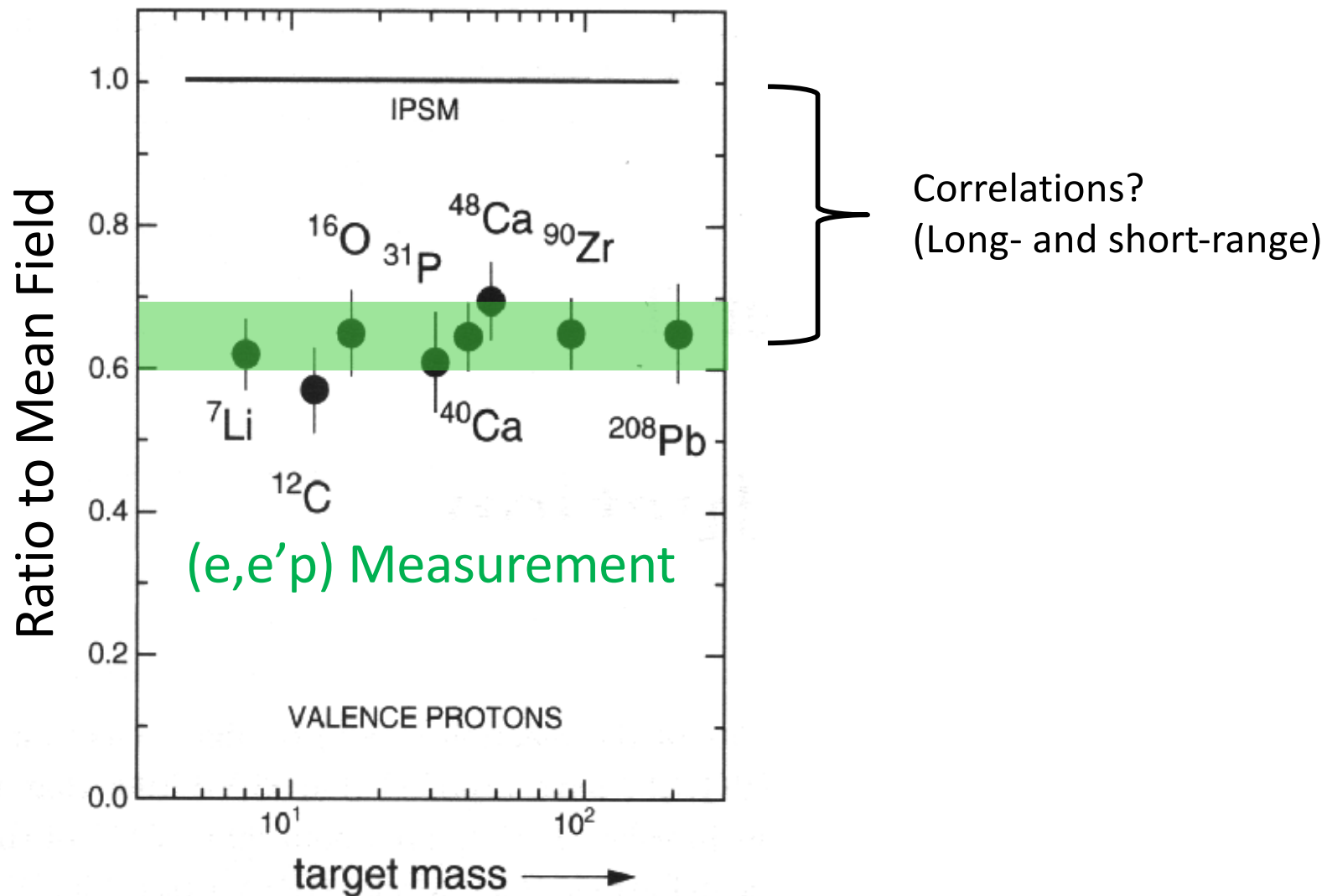

and it depends on nuclear asymmetry ...

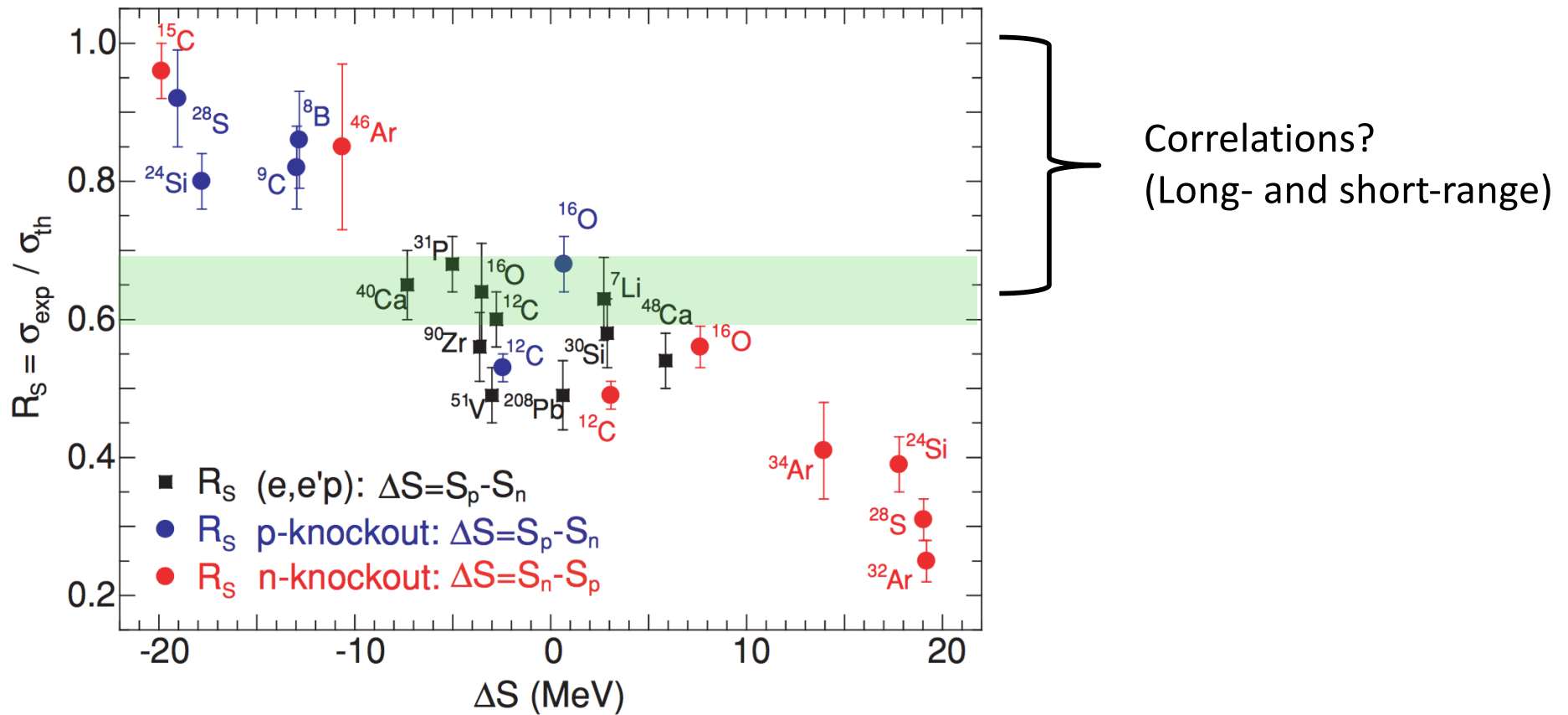

Minority nucleons have lower ratios to theory

A. Gade, PRC 77, 044306 (2008)

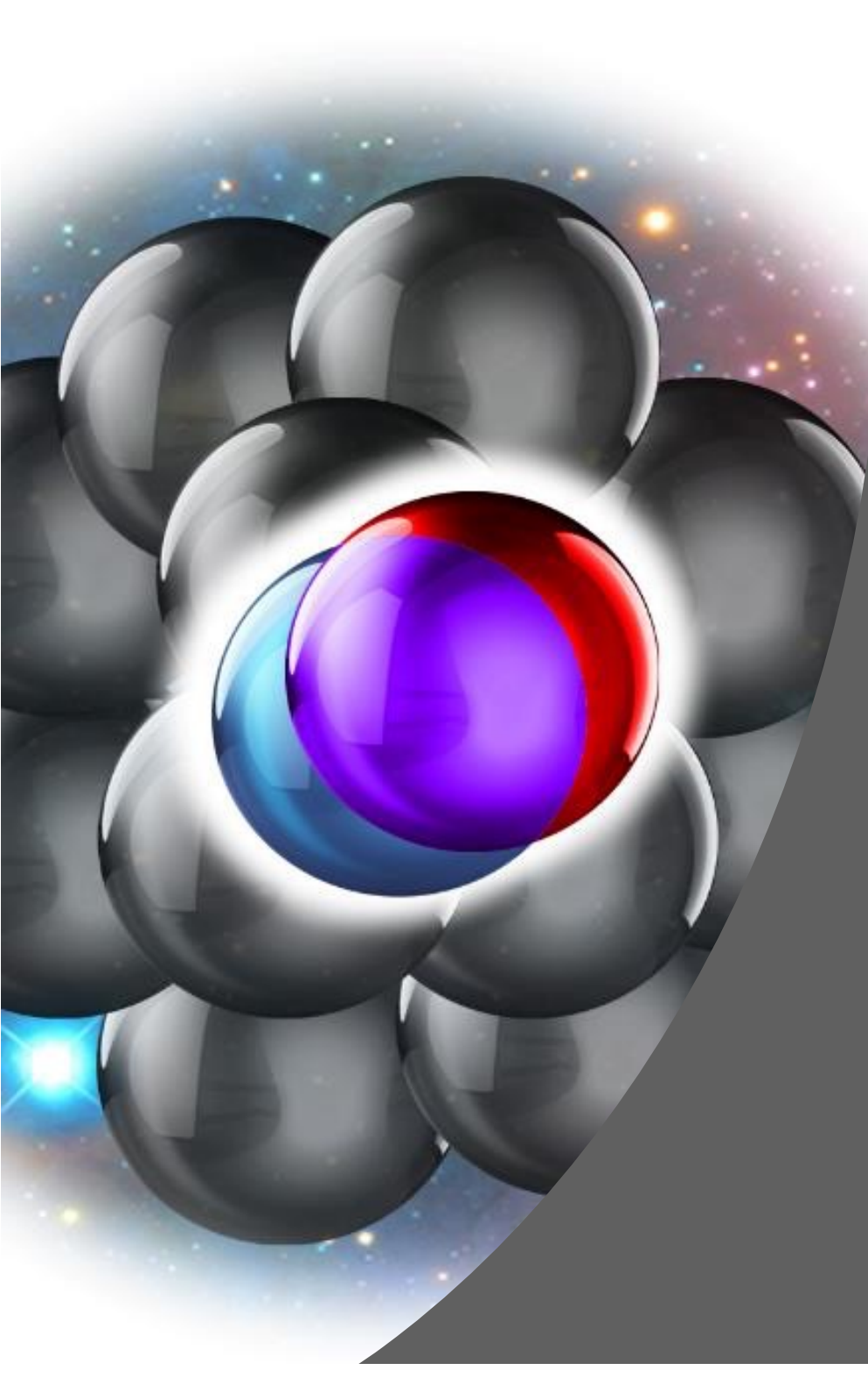

Short-Range Correlations (SRC)

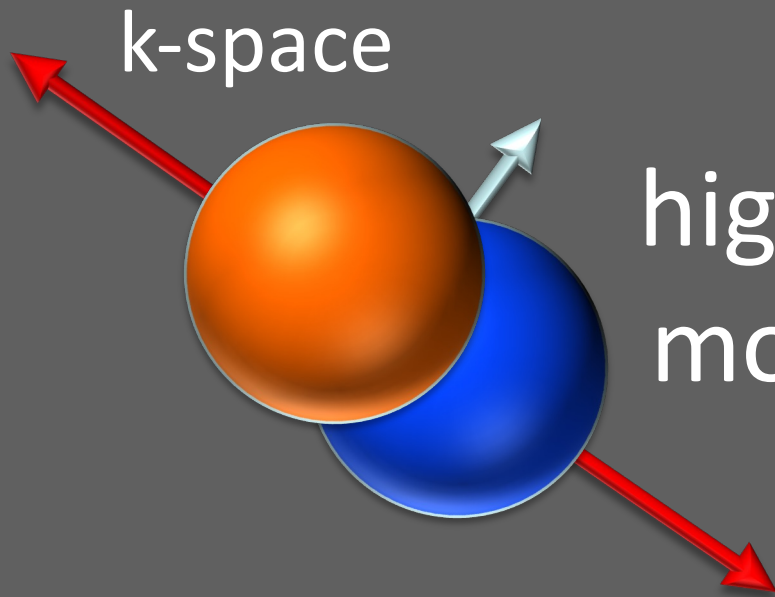

k-space

high *relative* and lower *c.m.*
momentum compared to k_F

Close together
nucleon pairs

r-space

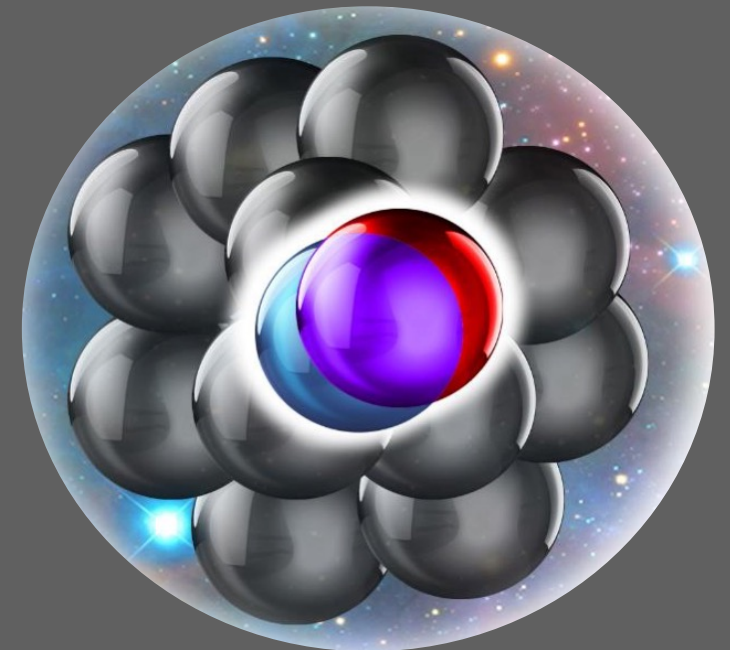

Looking For Correlations

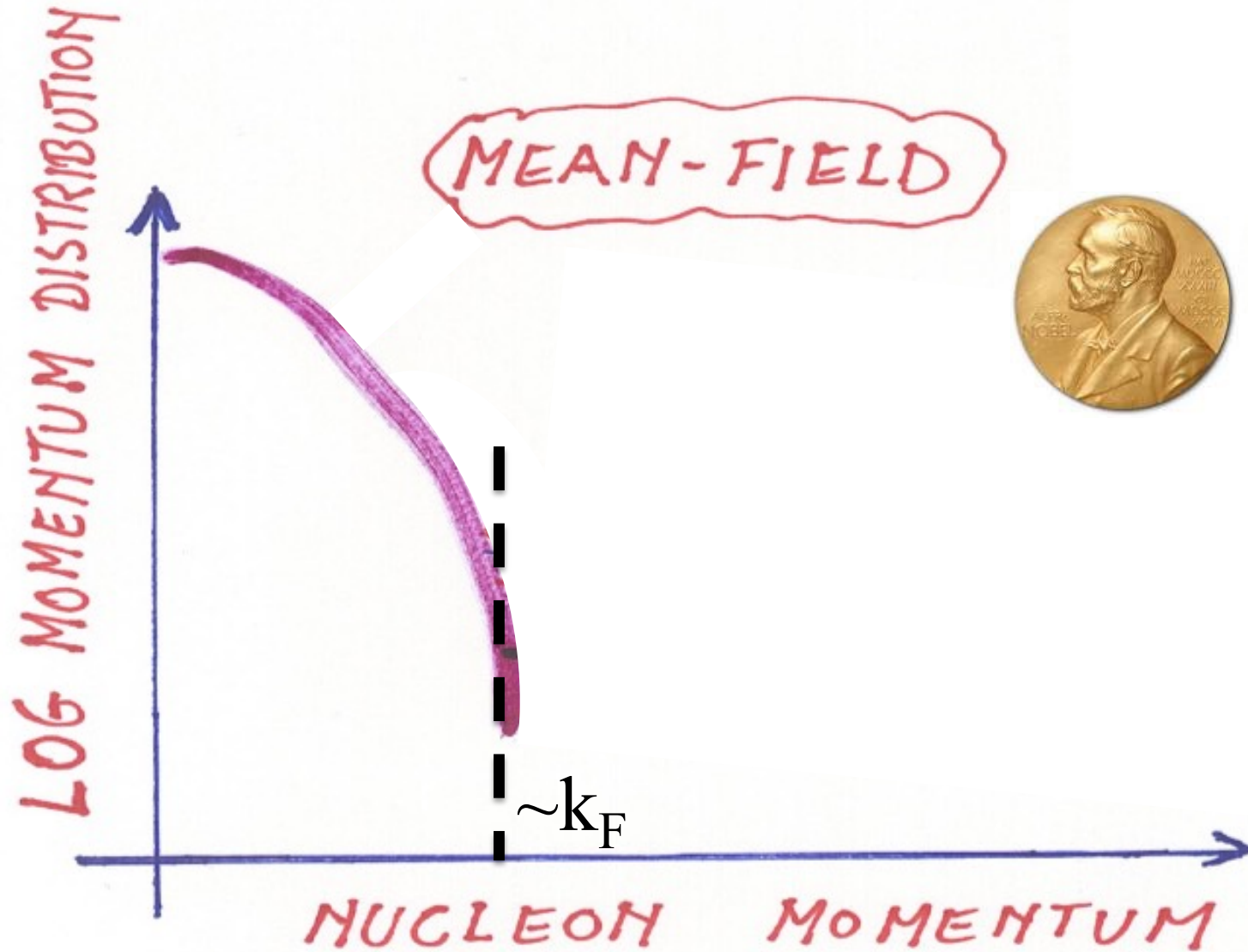

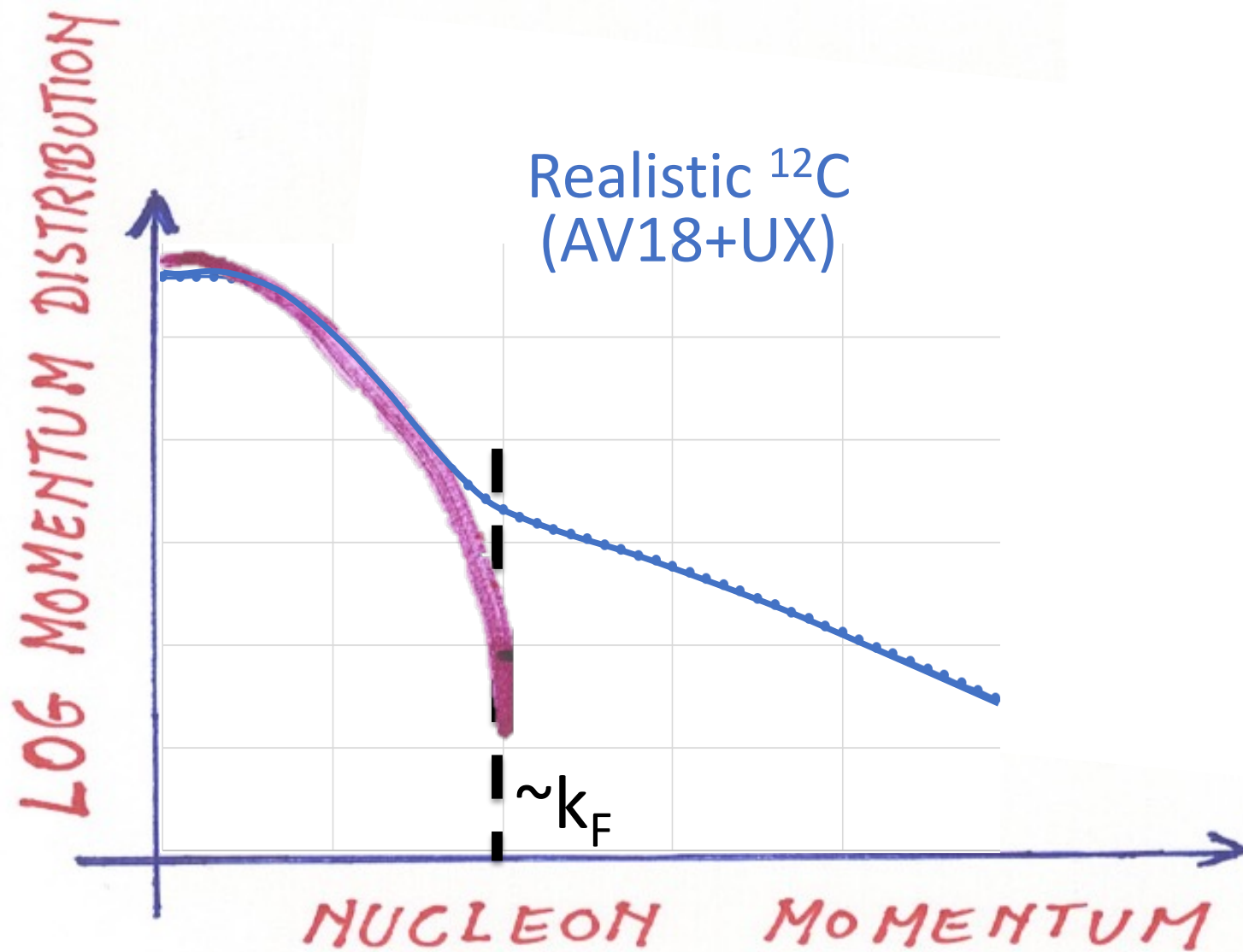

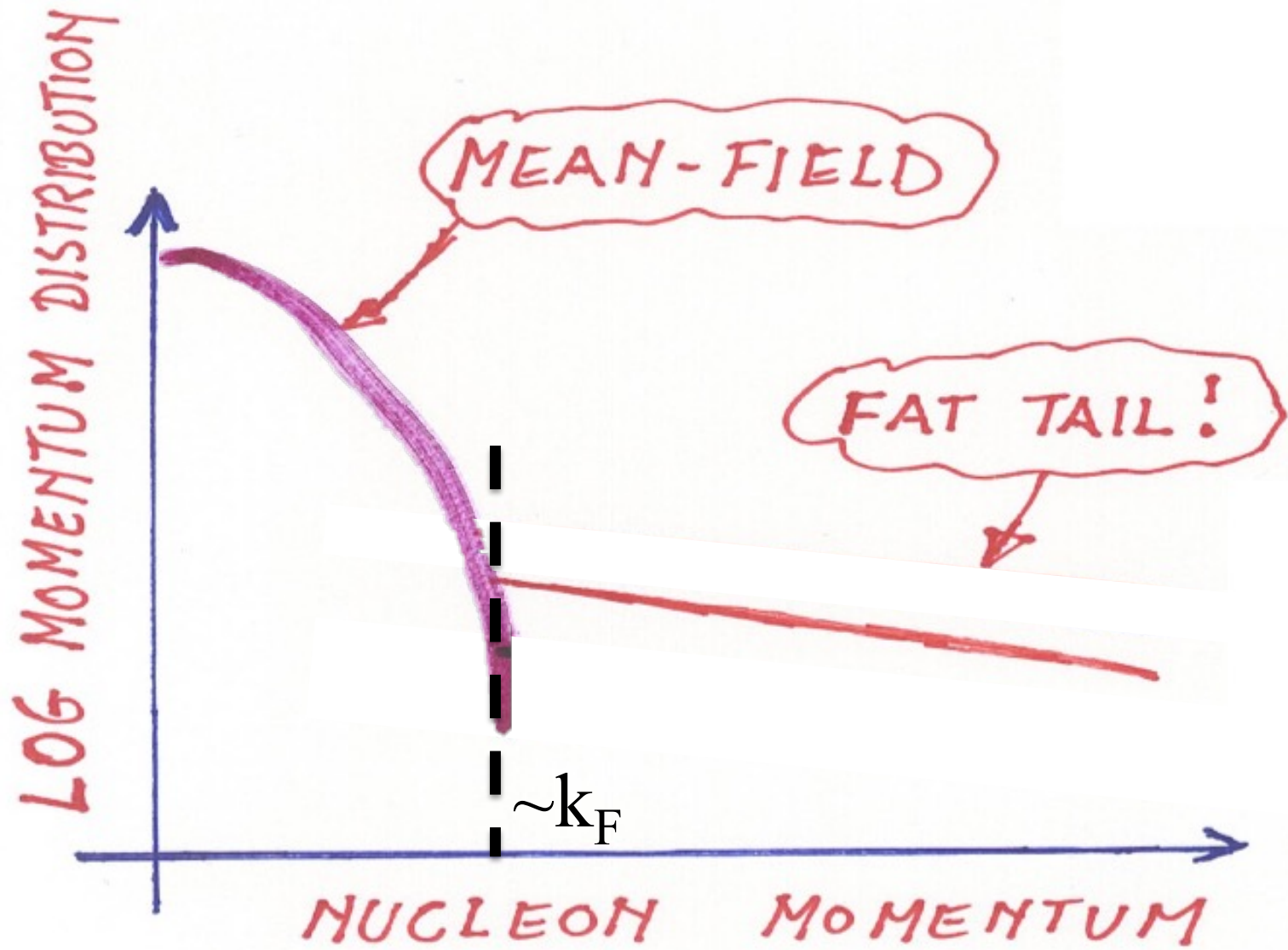

Correlations are Universal: $A(e,e') / d(e,e')$

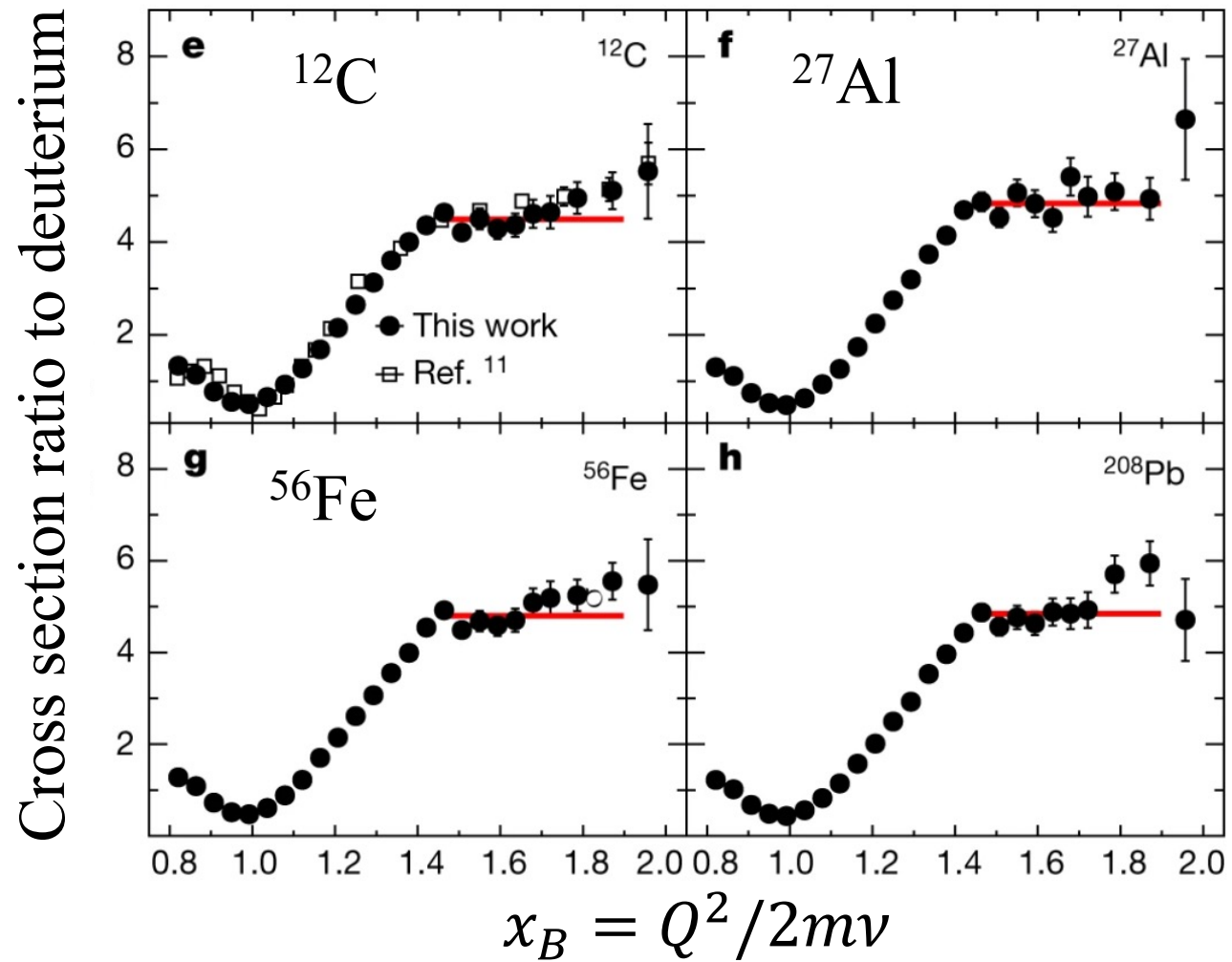
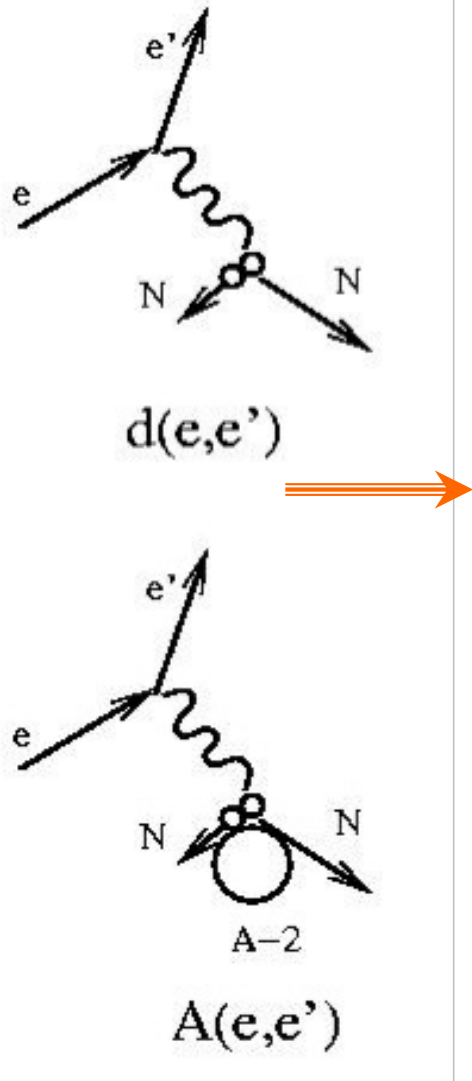

$\alpha_{2N} \approx 20\%$

Momentum range of plateau

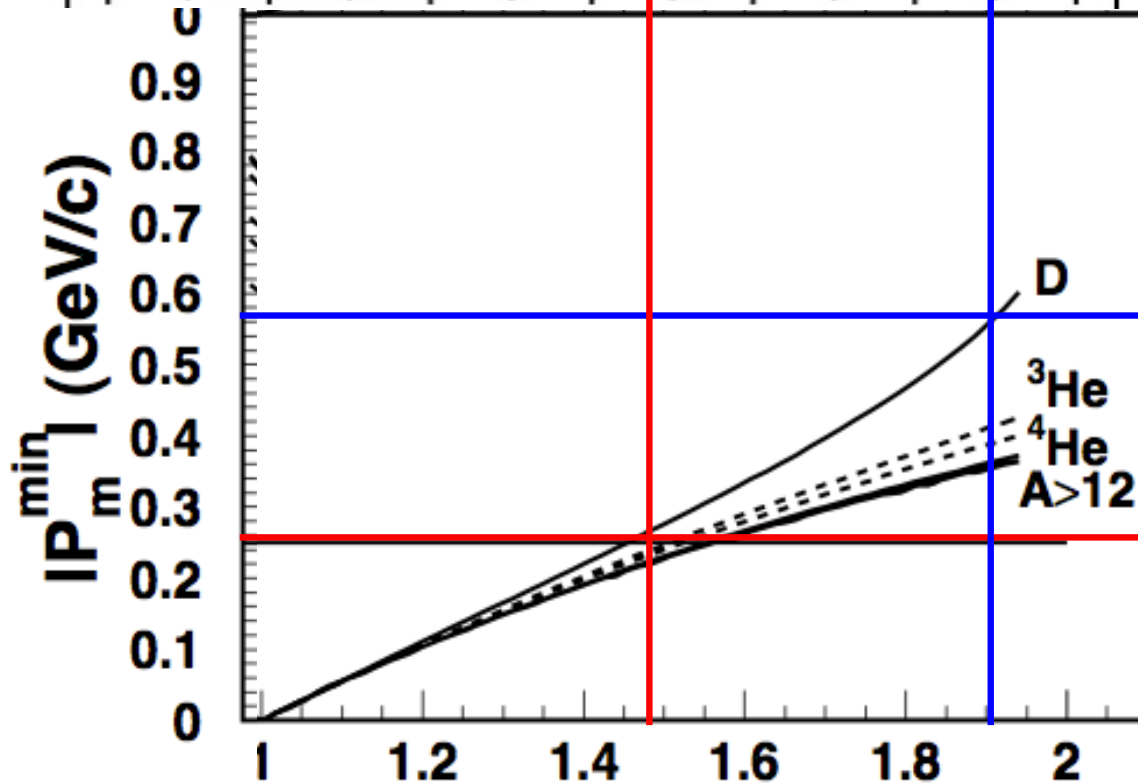
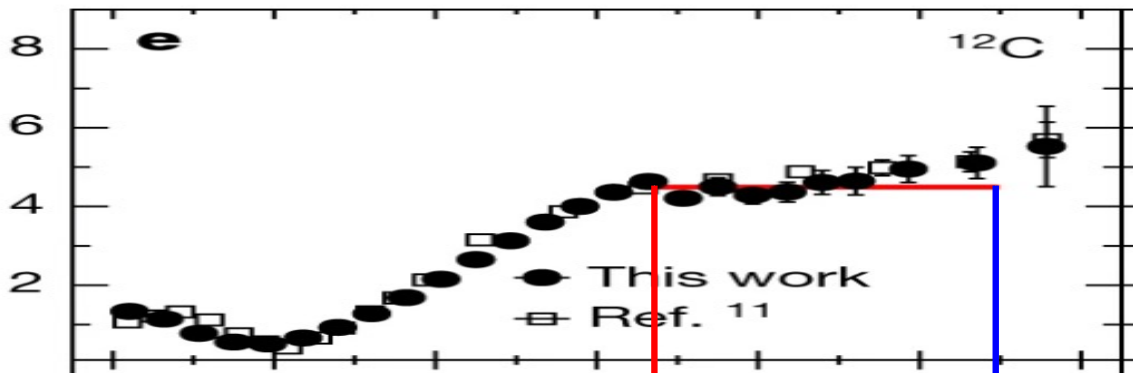

600 MeV/c

275 MeV/c

x_B

$$x_B = Q^2 / 2mv$$

Scale separation

Long range /
low momentum
region

Nucleus
dependent

“Mean Field”

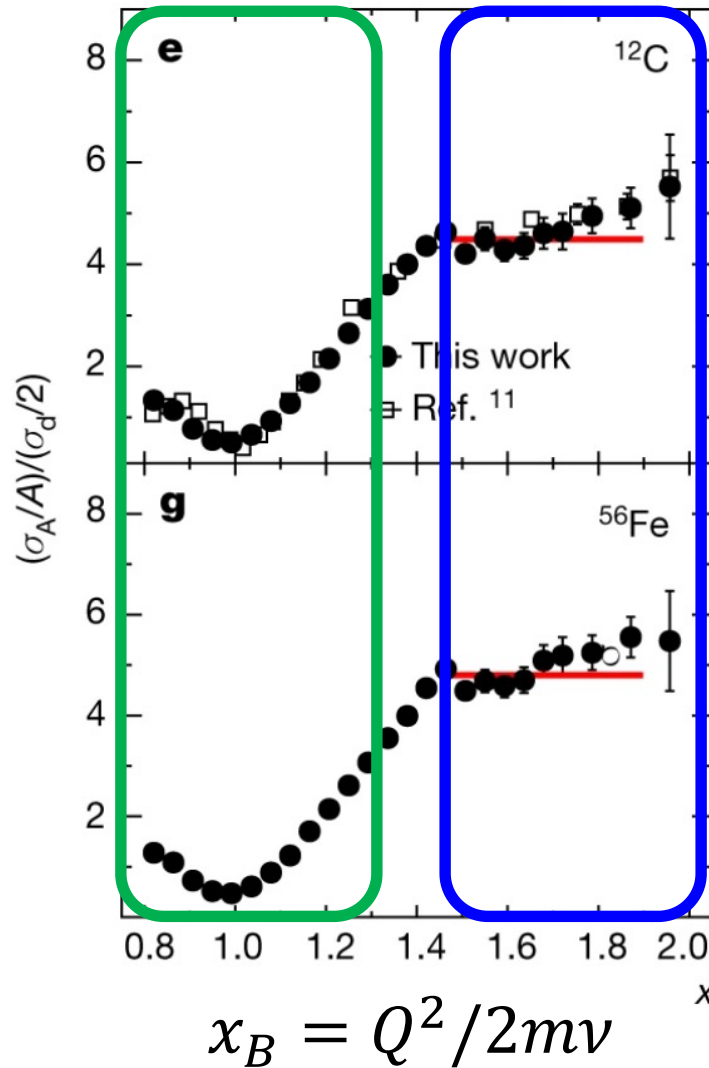

Short distance /
high momentum
region

Nucleus
independent

“Short Range
Correlations”

Many-Body Calculations

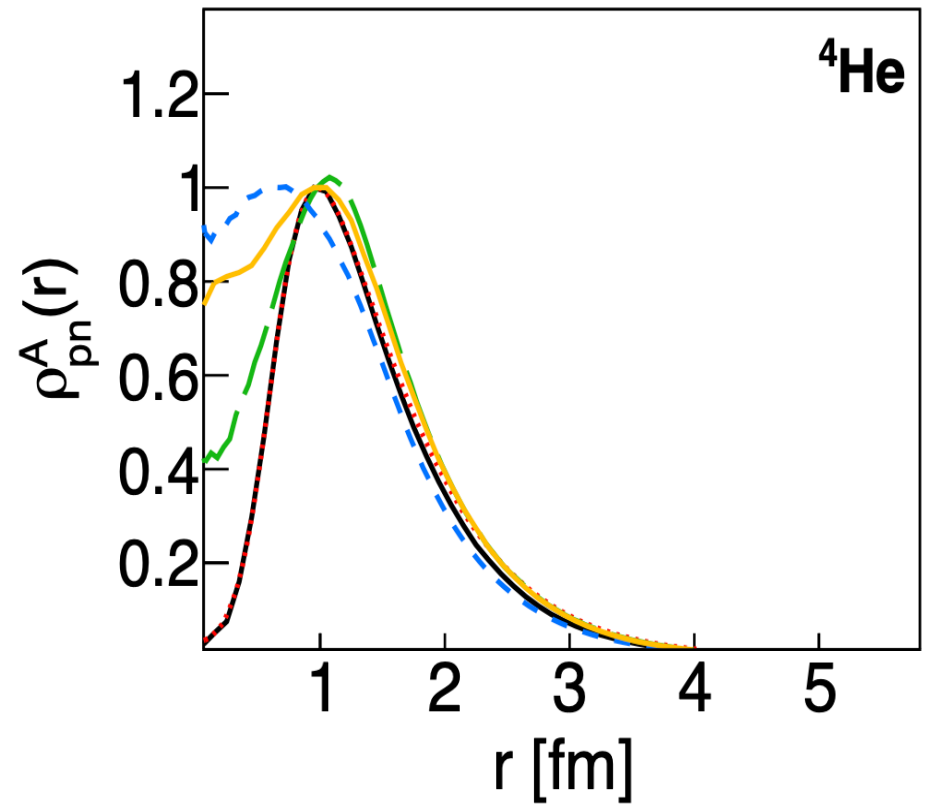
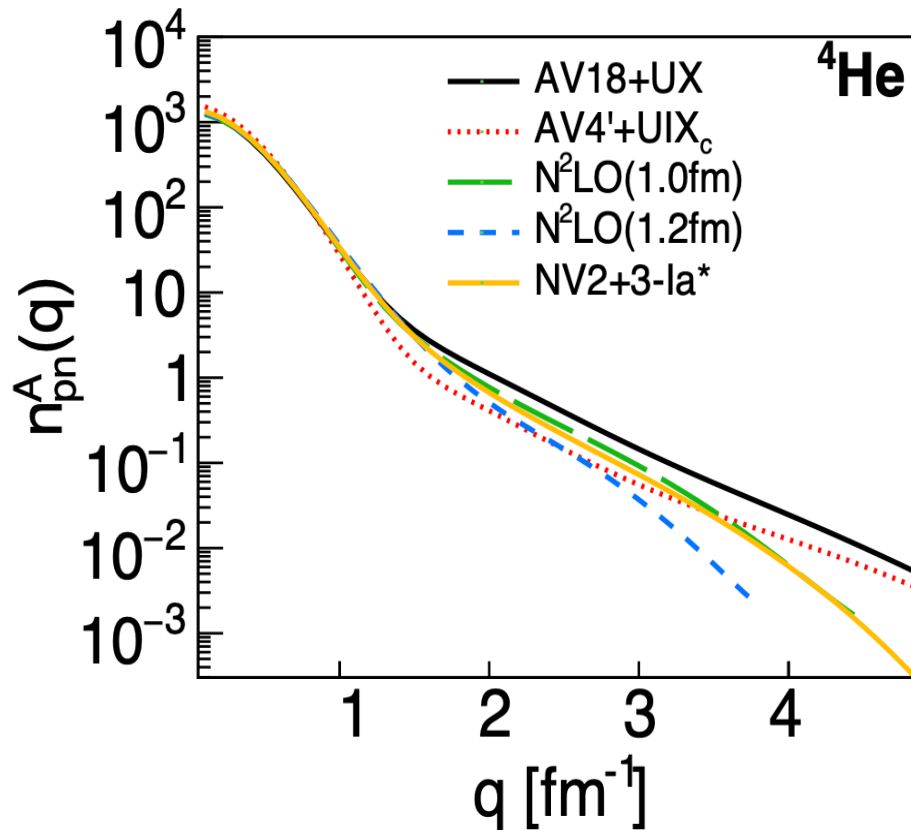

Model Dependence @ high-k / small r

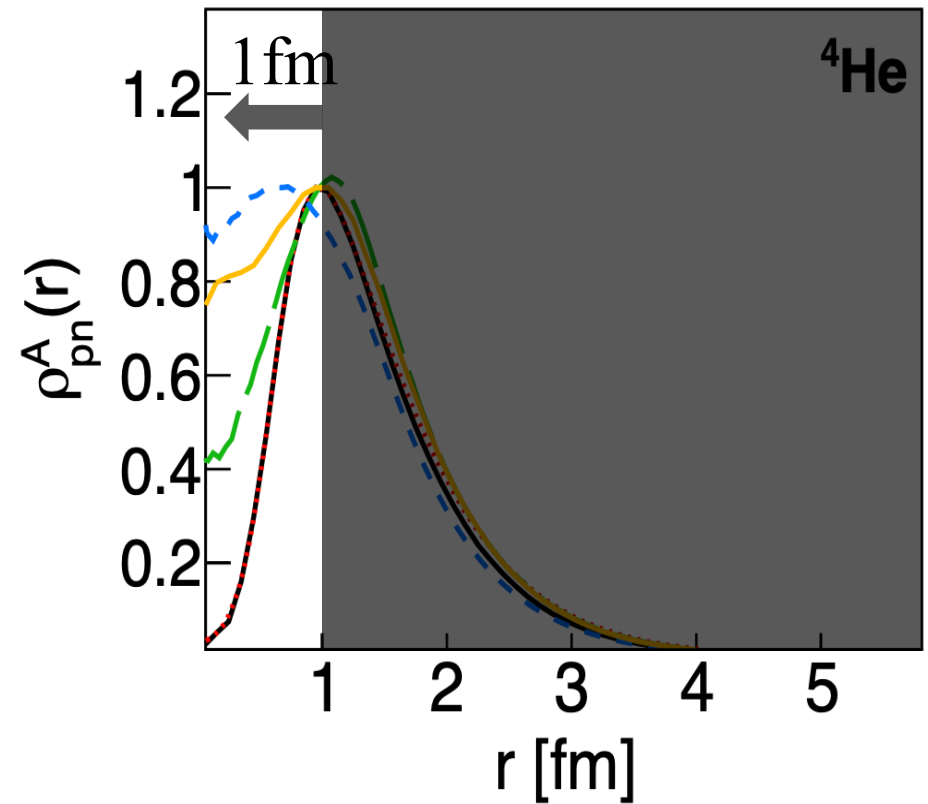
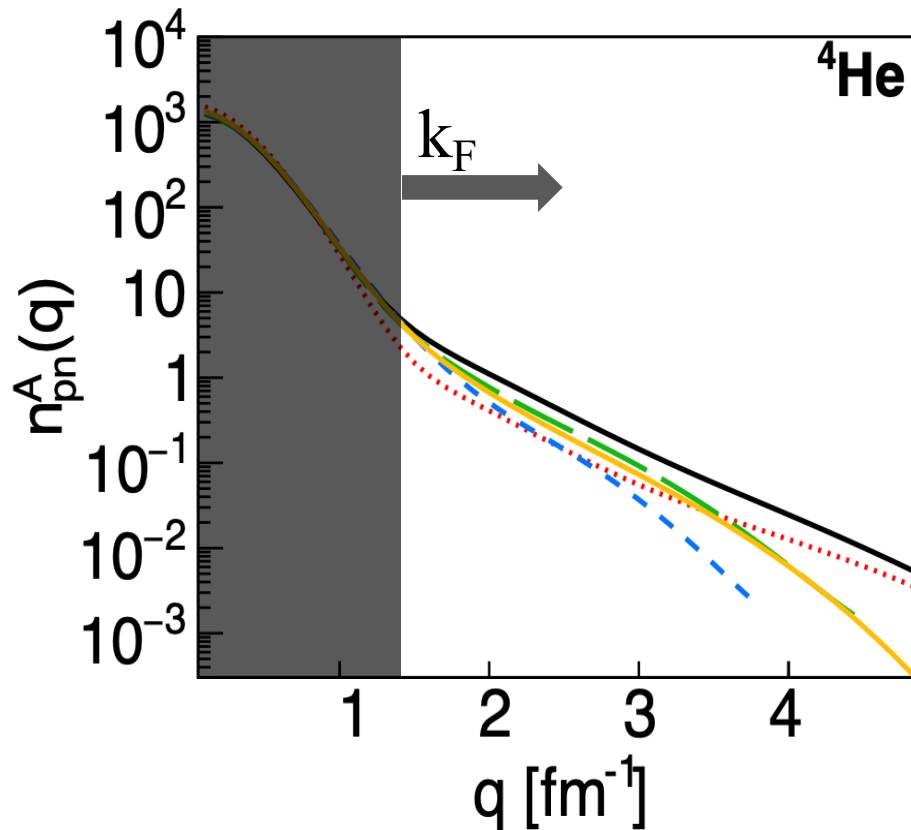

One nucleus, many models

Pairs \Leftrightarrow Scale Separation

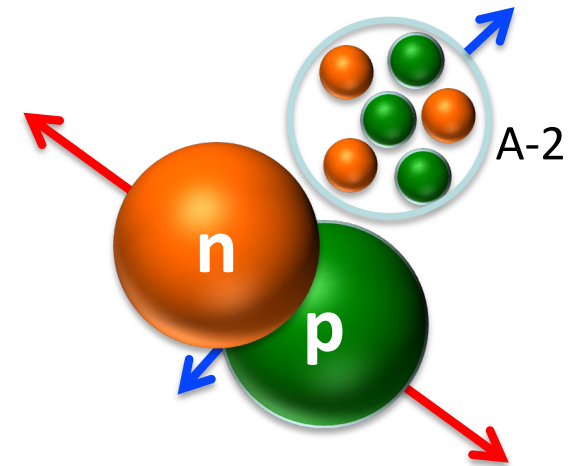
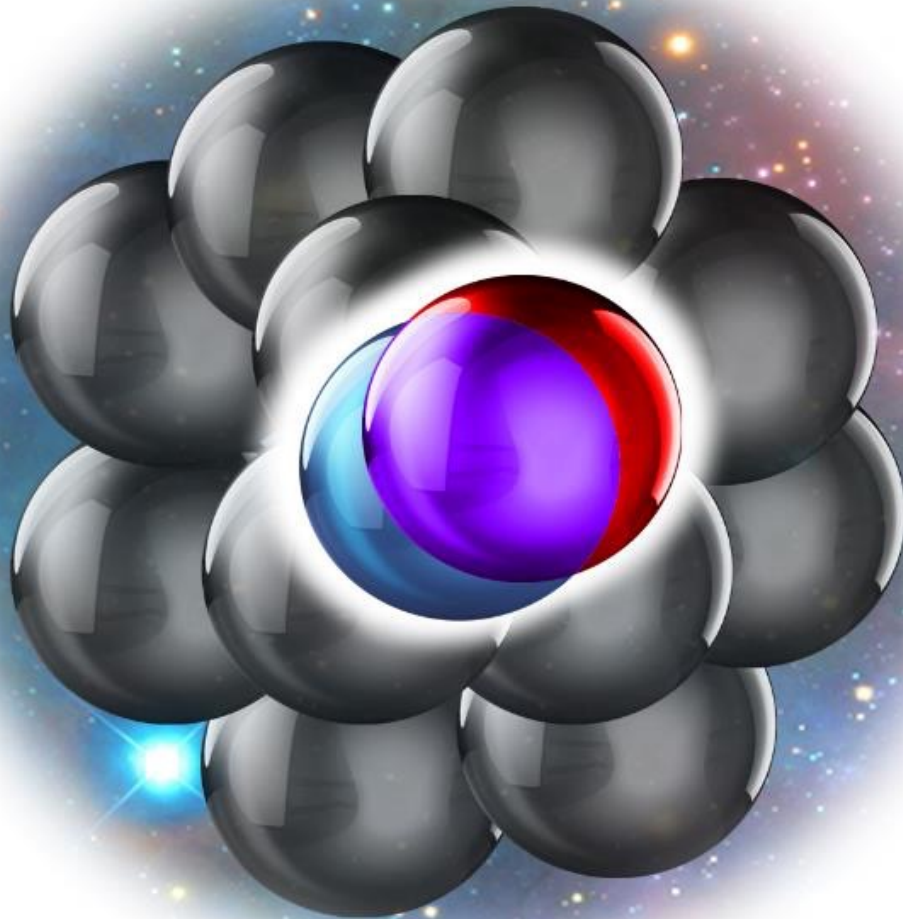

R. Cruz-Torres et al., Nature Physics (2020) J.-W. Chen, W. Detmold, J. E. Lynn, A. Schwenk, PRL 119 (2017)
R. Weiss et al., Phys. Lett. B 780 (2018) R. Weiss, B. Bazak, N. Barnea, Phys. Rev. C 92 (2015)

SRCs from Quantum Monte-Carlo (QMC): Pair Distance Distributions

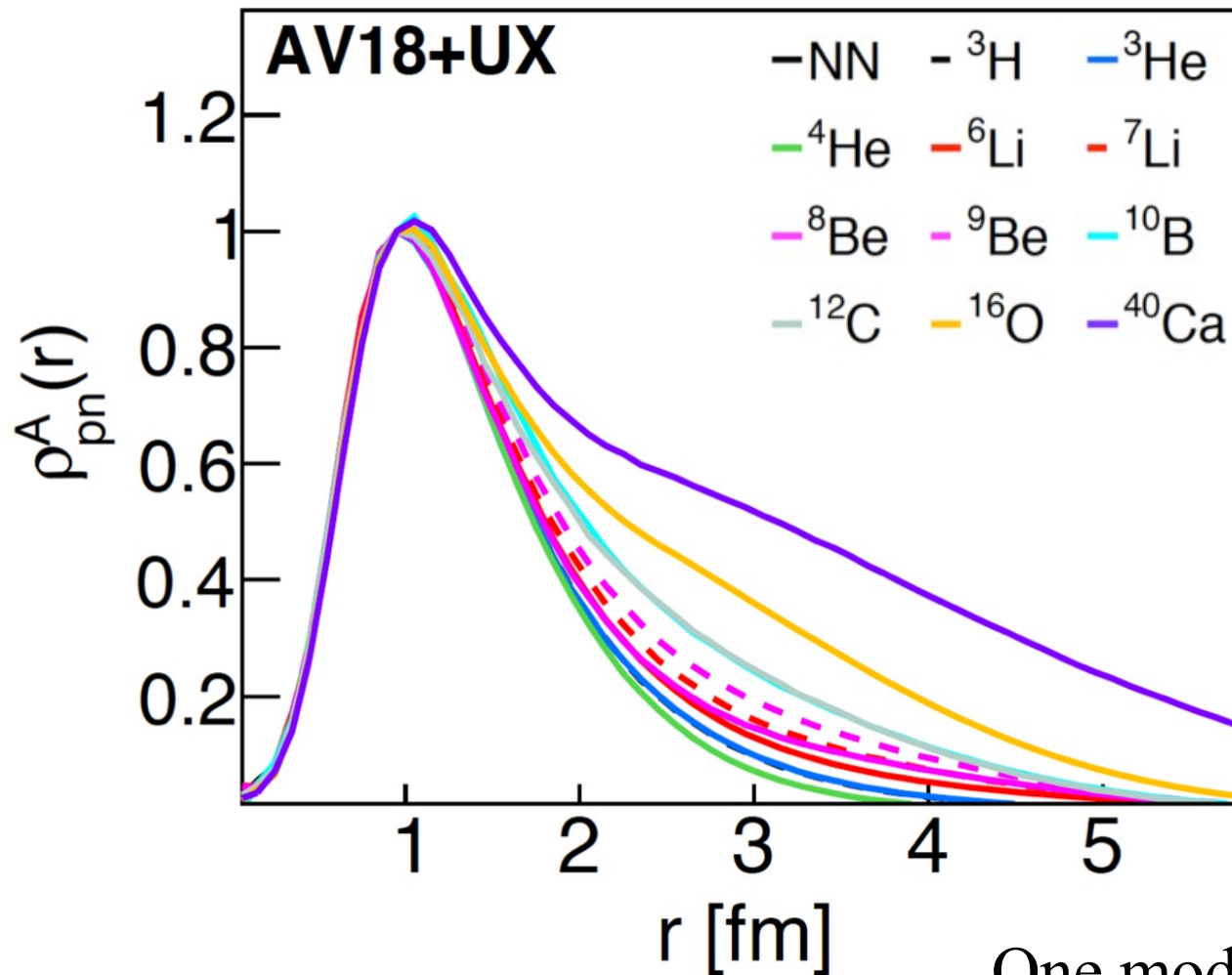

One model, many nuclei

Many Body = Constant x Two-Body

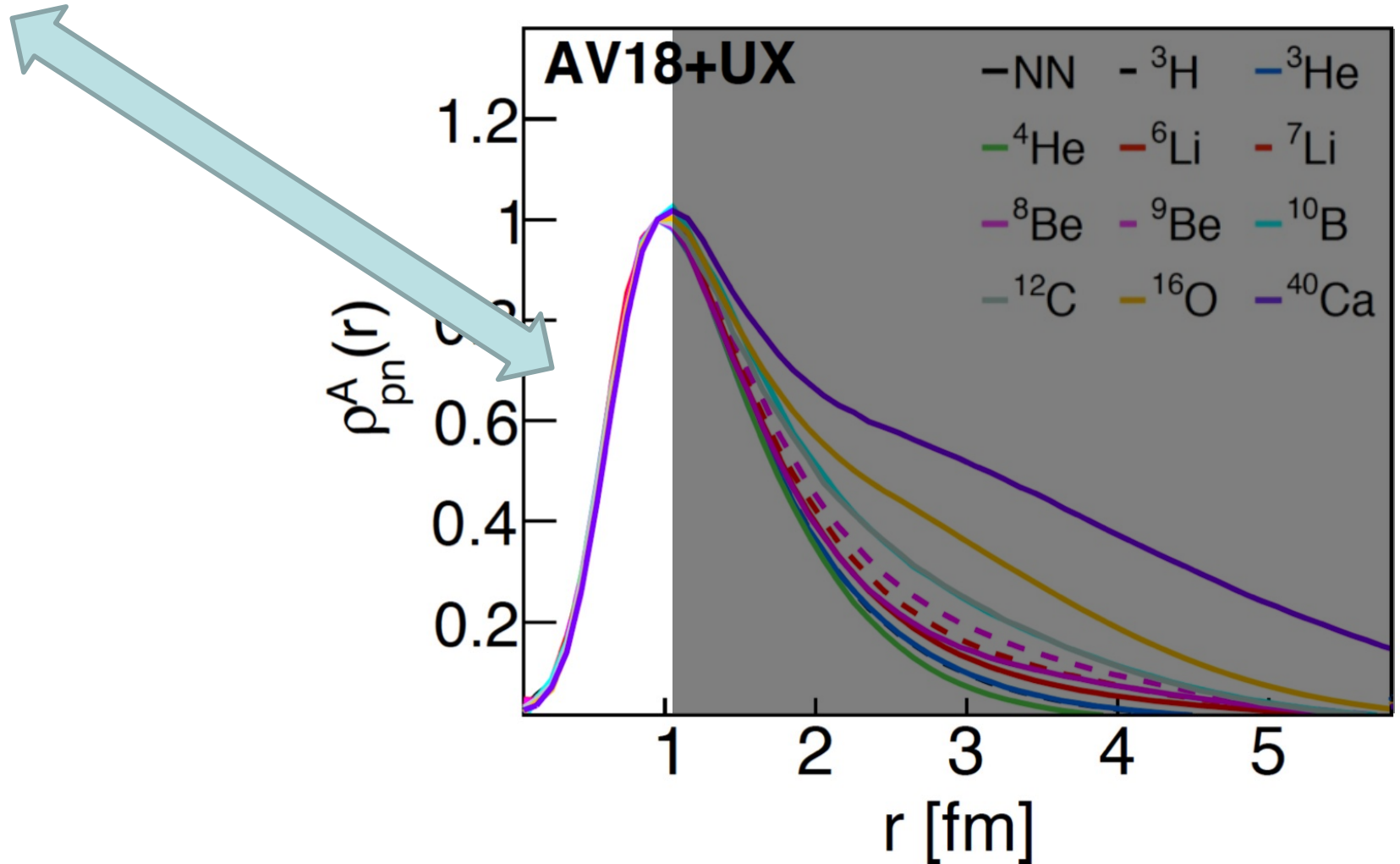

$$\rho_A^{NN,\alpha}(r) = C_A^{NN,\alpha} \times |\varphi_{NN}^\alpha(r)|^2$$



Many Body = Constant x Two-Body

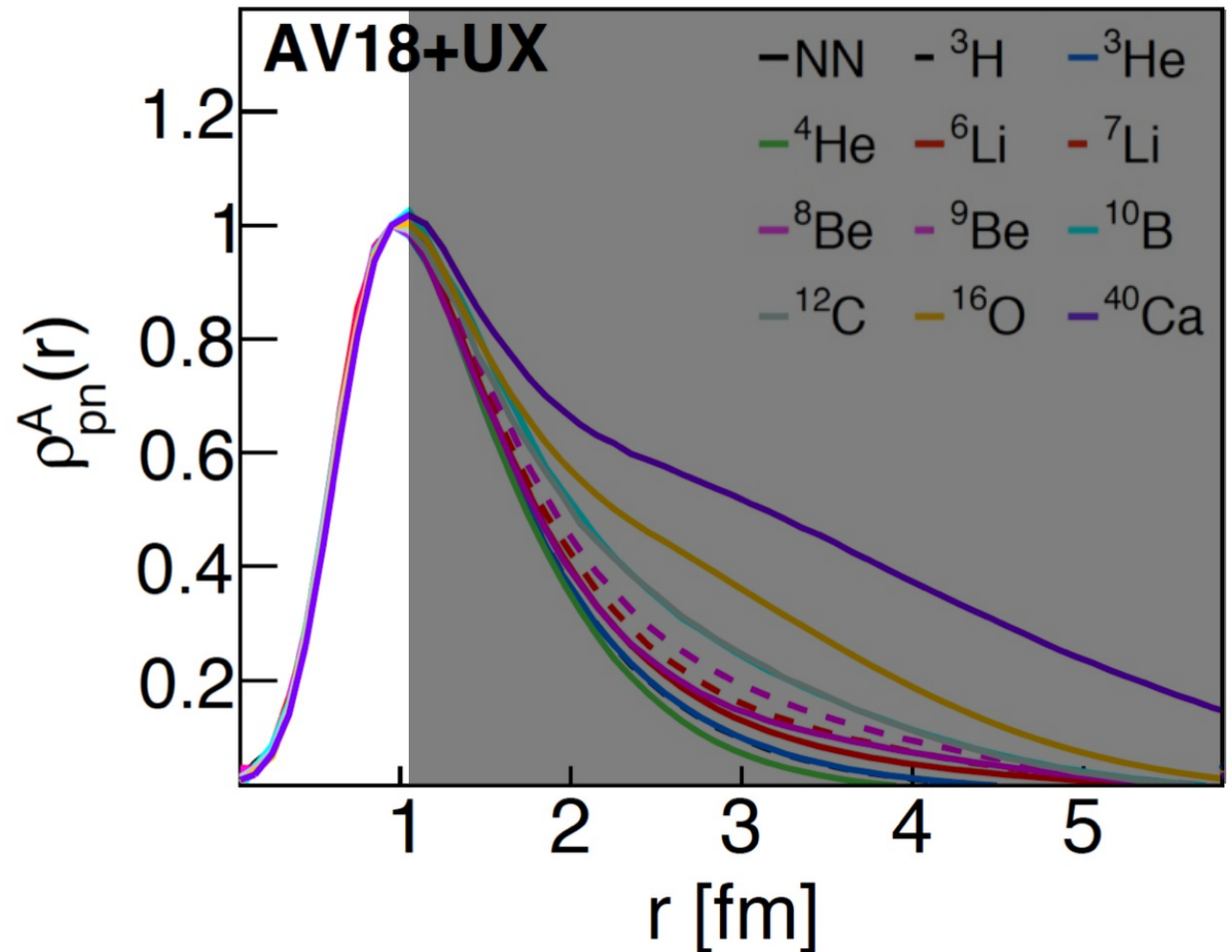

Factorization is *model* Independent

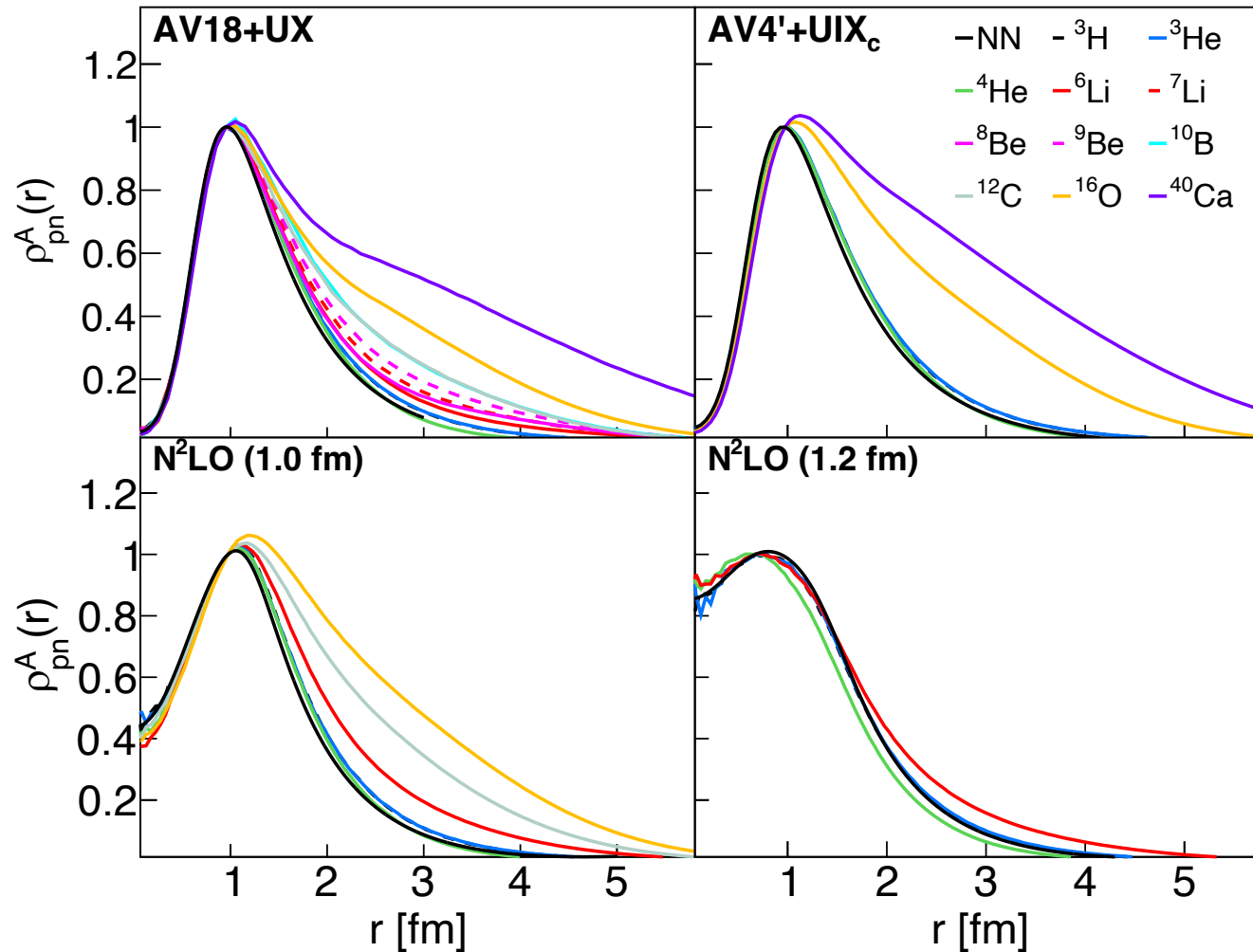

Many models, many nuclei

Scale Separation

$$\rho_A^{NN,\alpha}(r) = C_A^{NN,\alpha} \times |\varphi_{NN}^\alpha(r)|^2$$

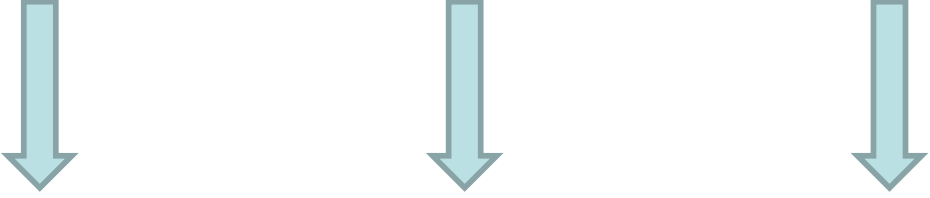

Total Dist. = Constant x Two-body
(Low-Energy) (High-Energy)

R. Cruz-Torres et al., Nature Physics (2020)

R. Weiss et al., Phys. Lett. B 780 (2018)

J.-W. Chen, W. Detmold, J. E. Lynn, A. Schwenk, PRL 119 (2017)

R. Weiss, B. Bazak, N. Barnea, Phys. Rev. C 92 (2015)

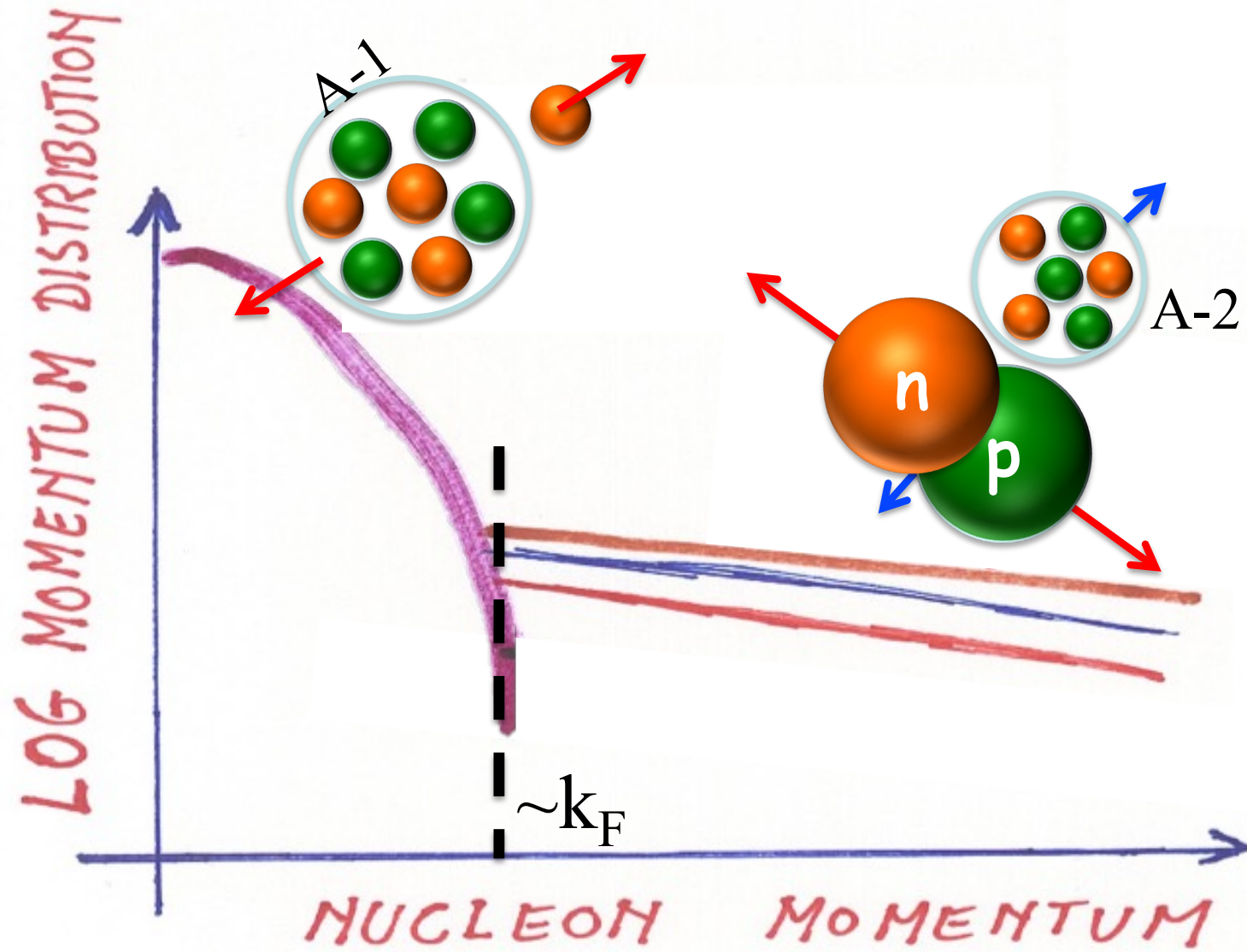

LOG MOMENTUM DISTRIBUTION

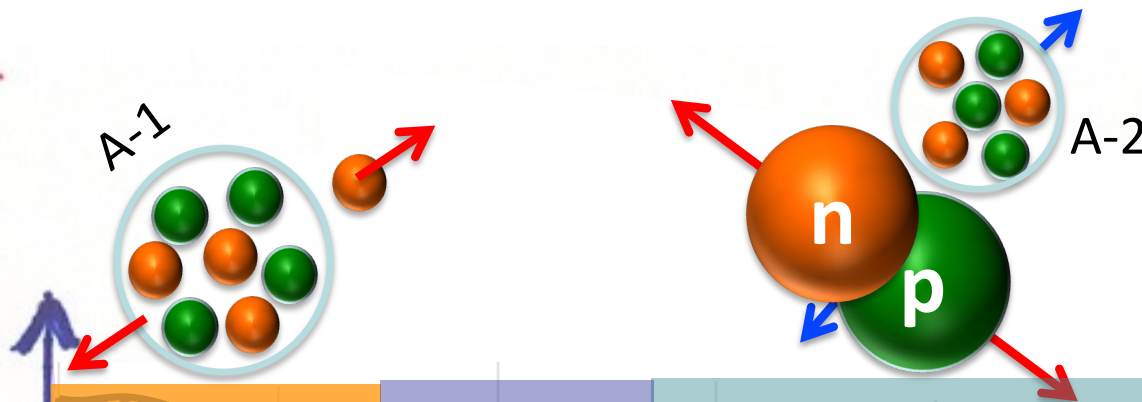

Mean
Field

?

Short-Range
Correlations

$\sim k_F$

NUCLEON MOMENTUM

Universality in Electron Scattering

Tag $A(e,e')$ with a high p_{miss} proton

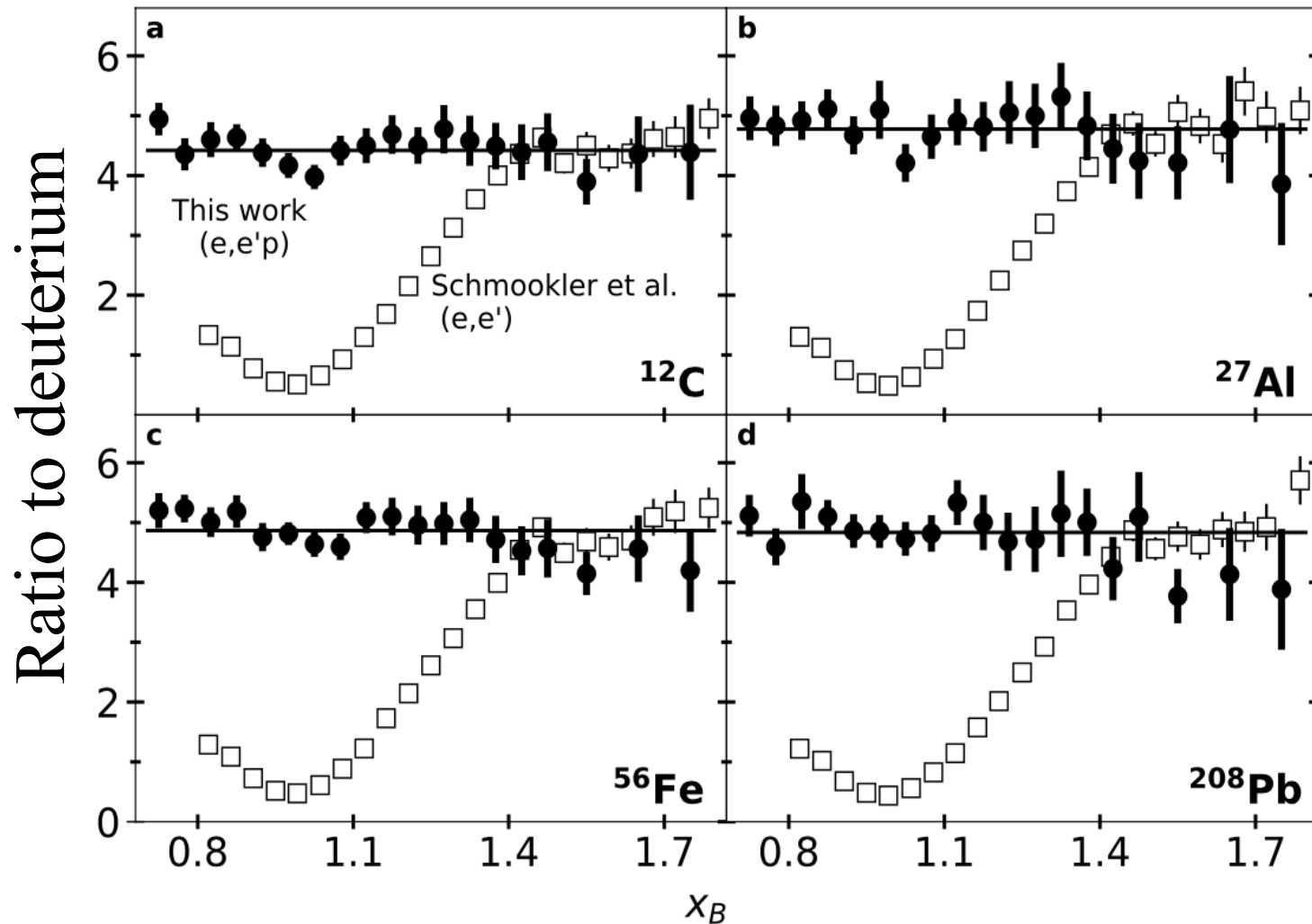

Scaling onset $\sim k_F$

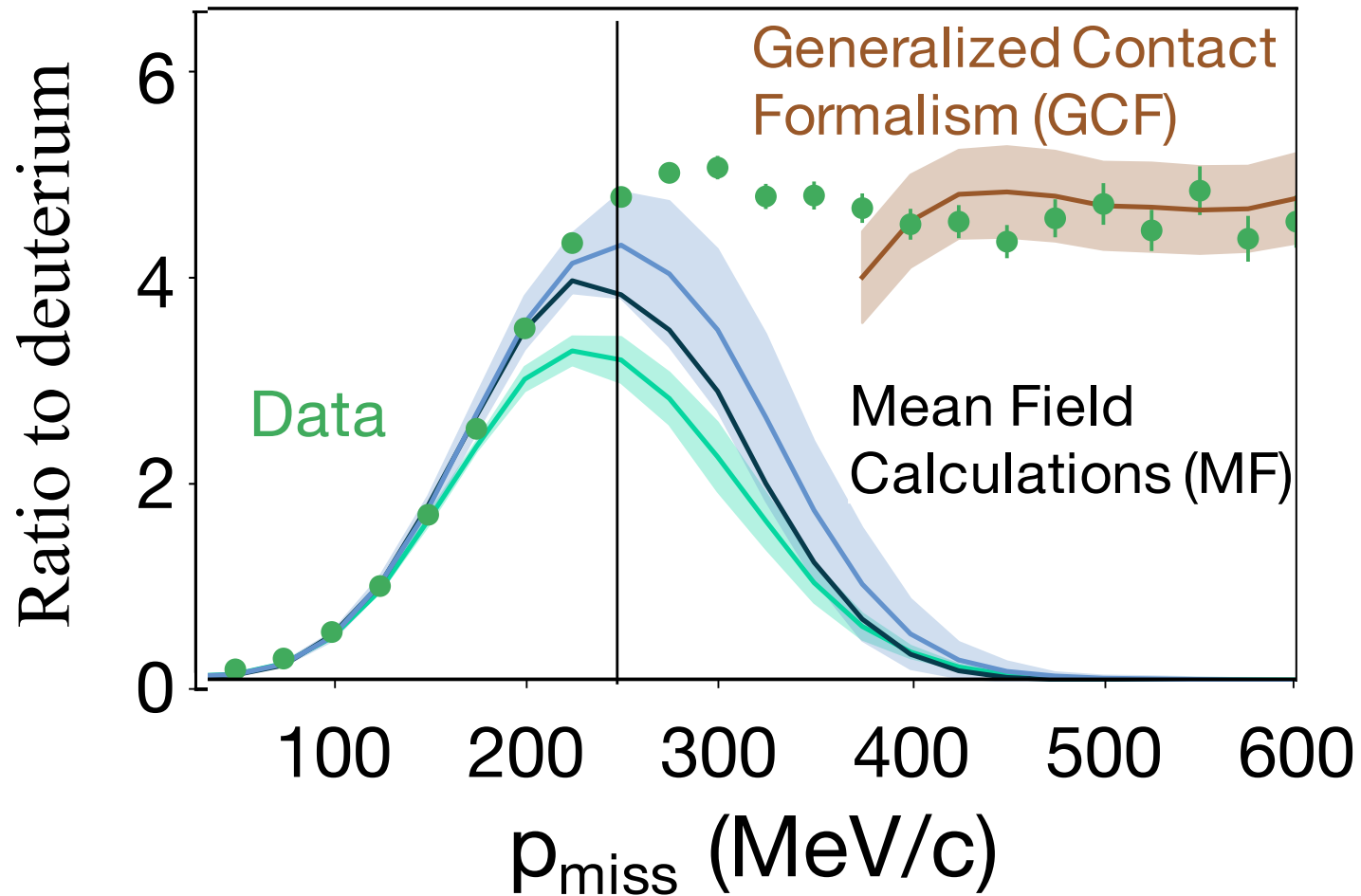

Scaling onset $\sim k_F$

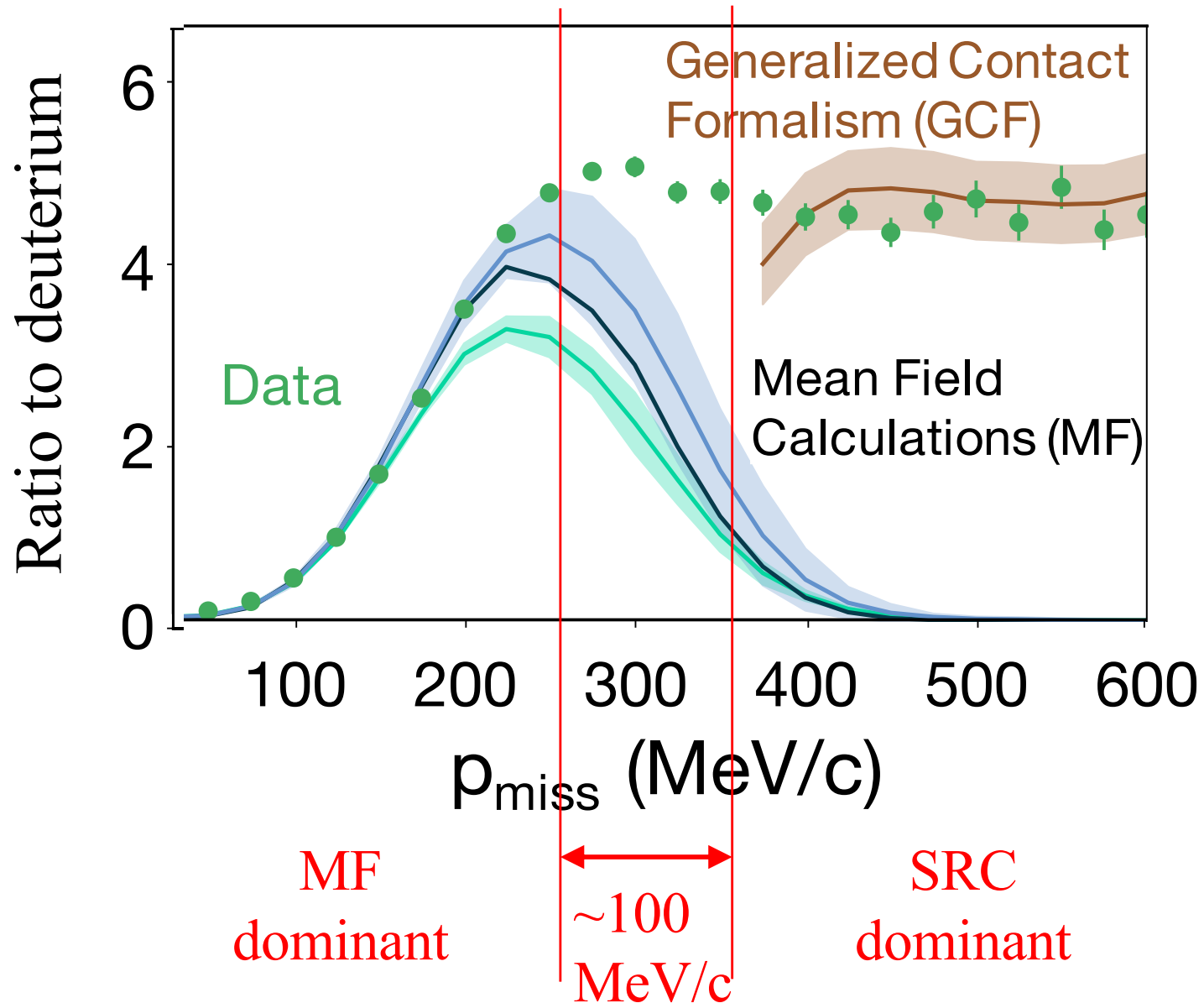

What are correlations?

Average Two-Nucleon Properties in the Nuclear Ground State

Two-body currents are **not** Correlations
(but add coherently)

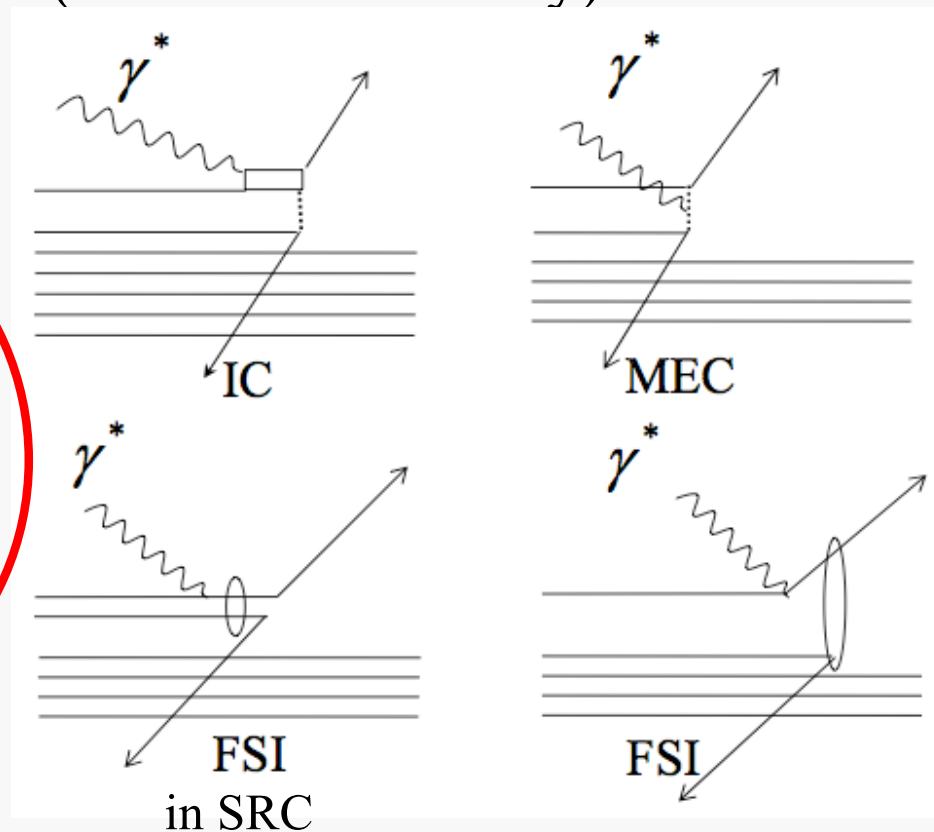
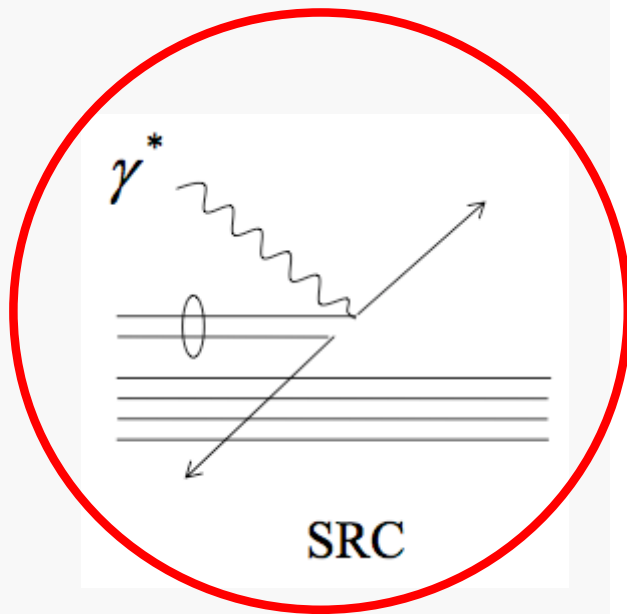

Choose kinematics to minimize these

Signatures for Correlations

An Experimentalist's Definition:

- A high momentum nucleon whose momentum is balanced by **one** other nucleon
 - *NN* Pair with
 - Large Relative Momentum
 - Small Total Momentum

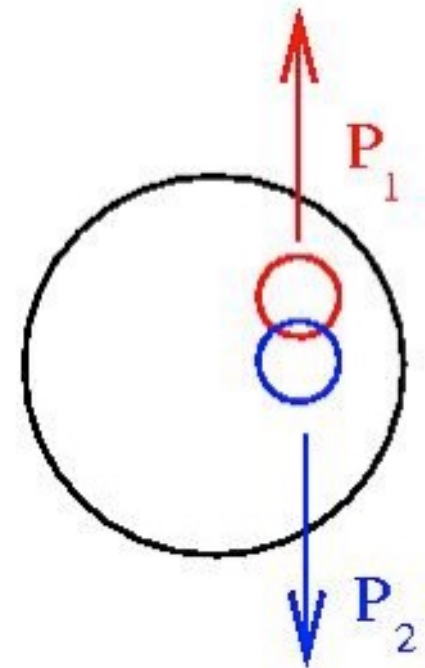

Breakup the pair =>
Detect **both** nucleons =>
Reconstruct 'initial' state

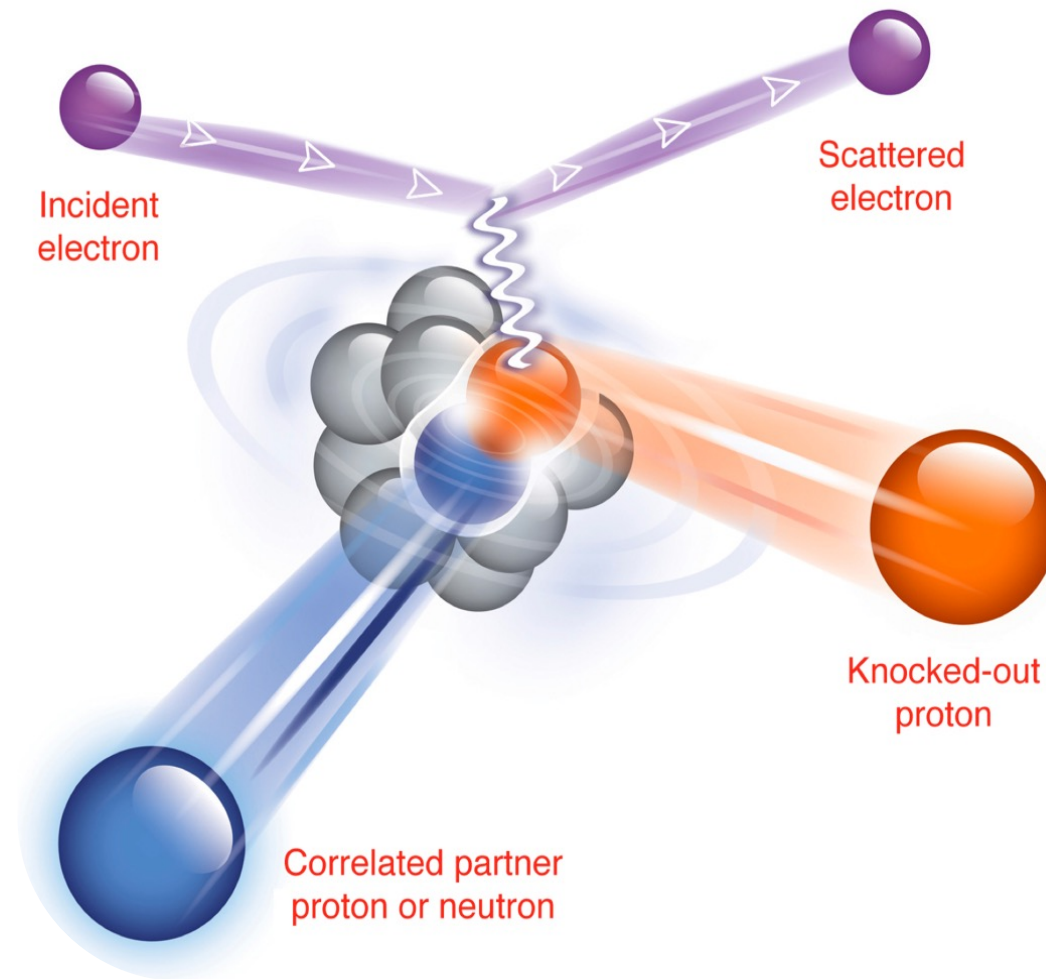

Jefferson Lab Site

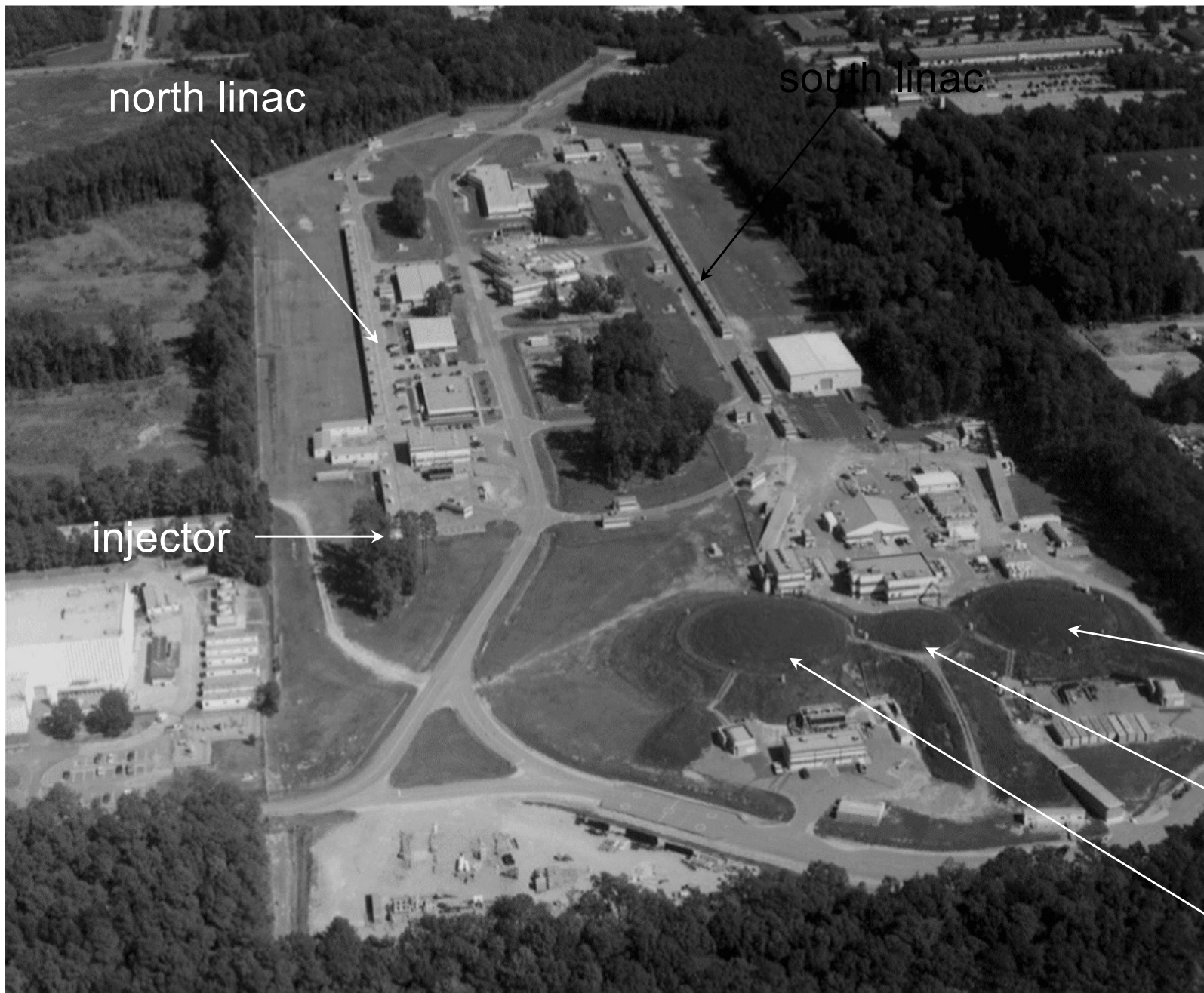

north linac

south linac

injector

Hall C

Hall B
CLAS

Hall A

Hall-A: High-Resolution Spectrometers

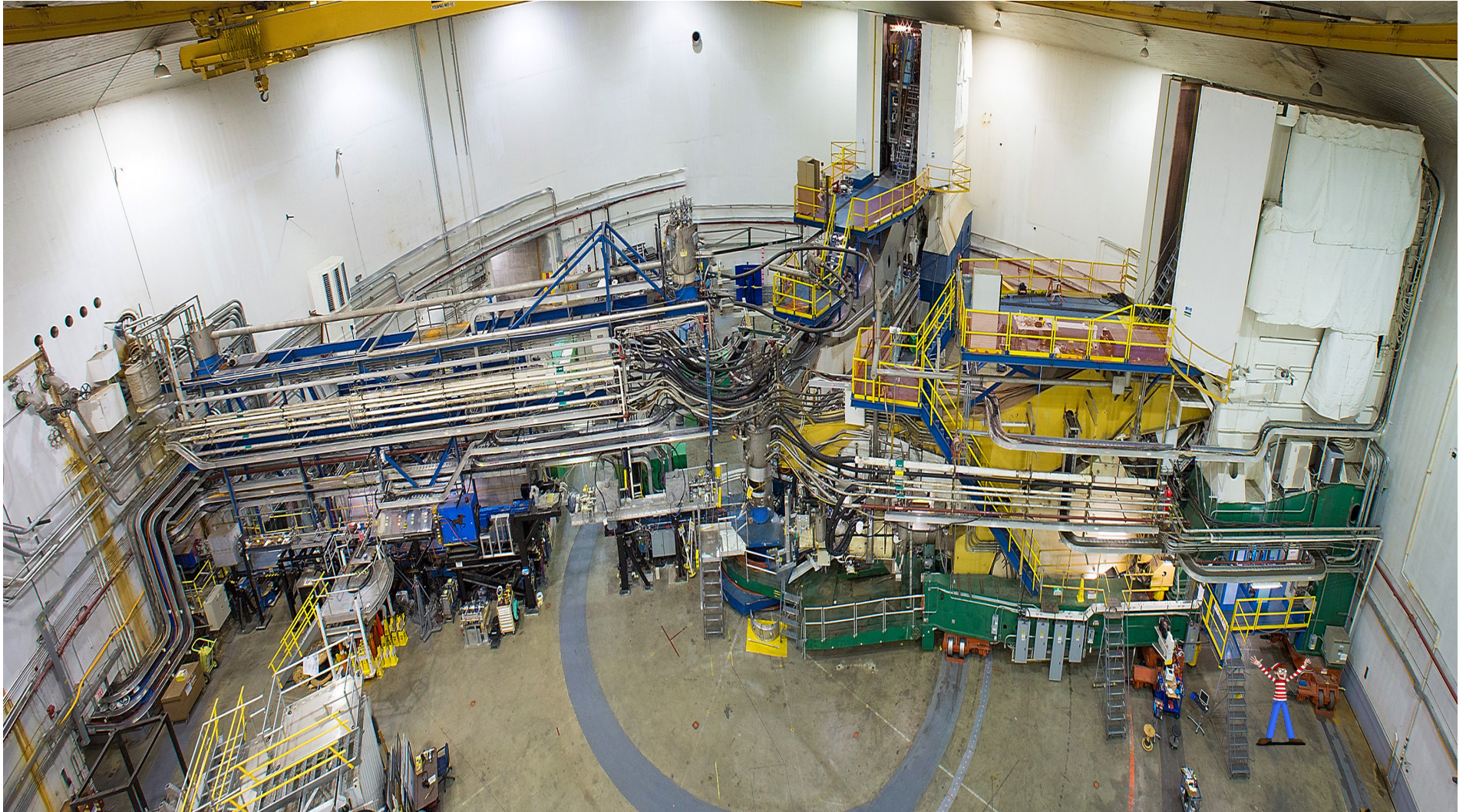

Hall-A: $A(e, e'pN)$

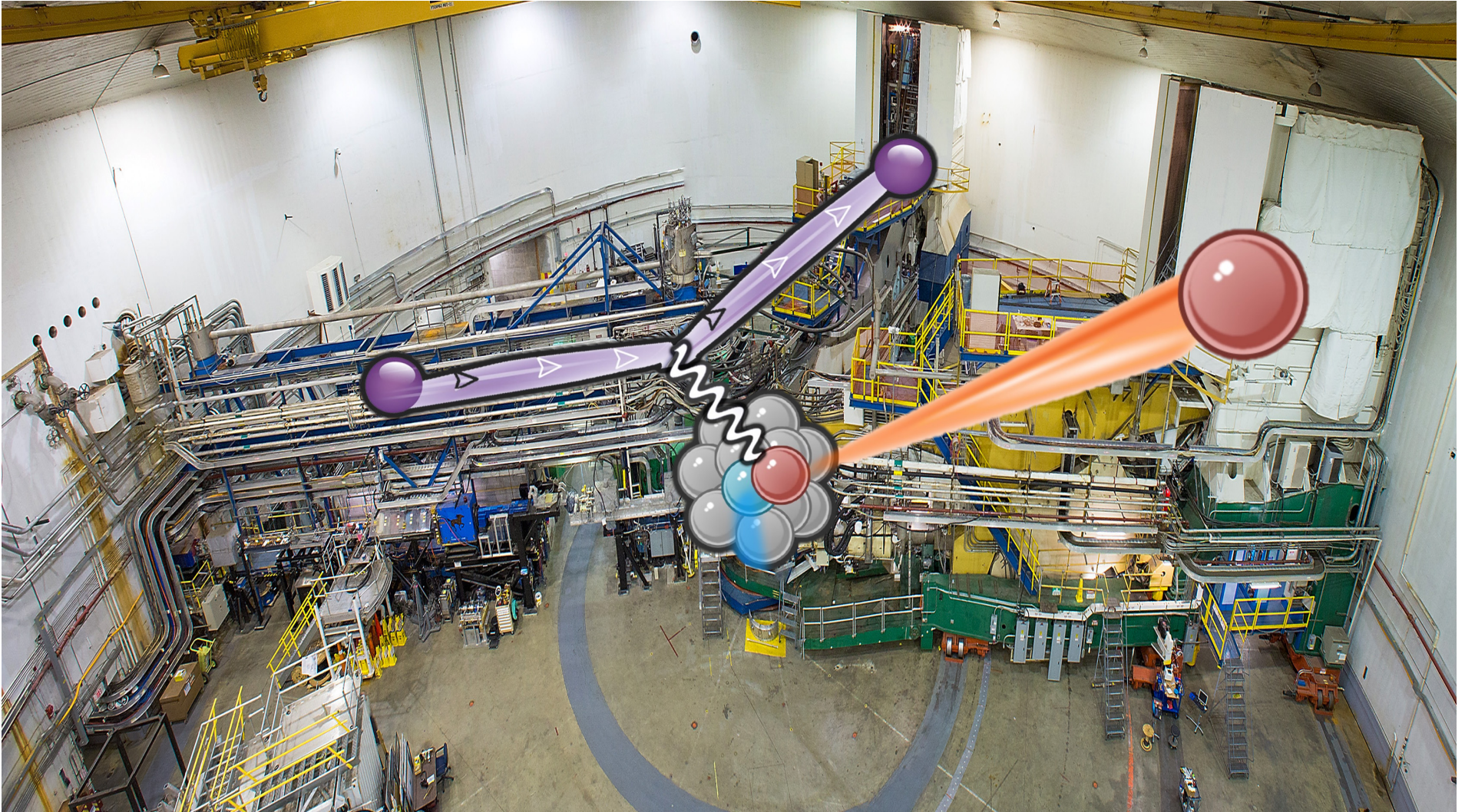

Hall-A: $A(e, e'pN)$

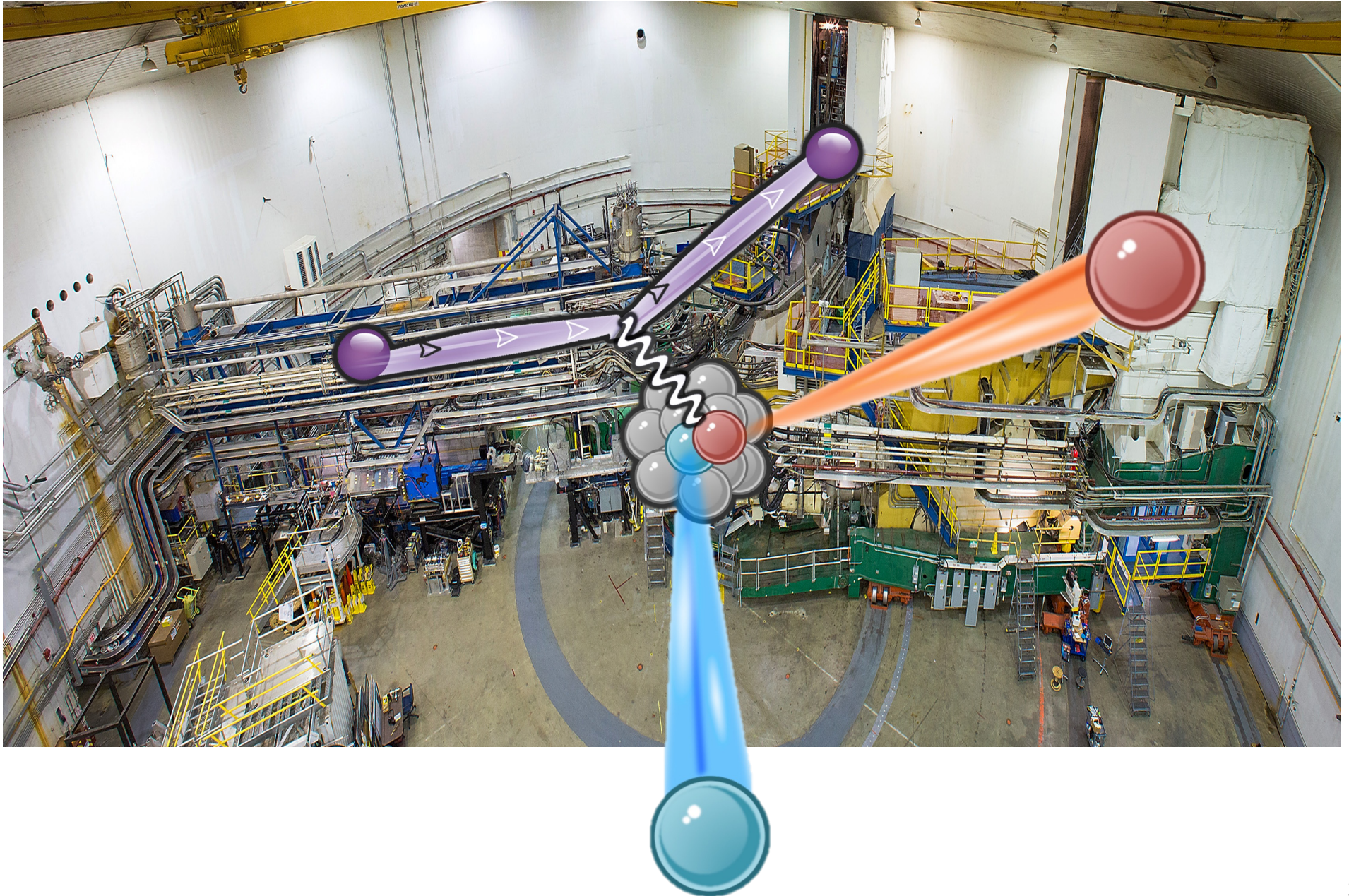

Hall A C(e,e'pN)

$$Q^2 = 2 \text{ GeV}^2$$

$$x_B = 1.2$$

$$P_{\text{miss}} = 300\text{-}600 \text{ MeV}/c$$

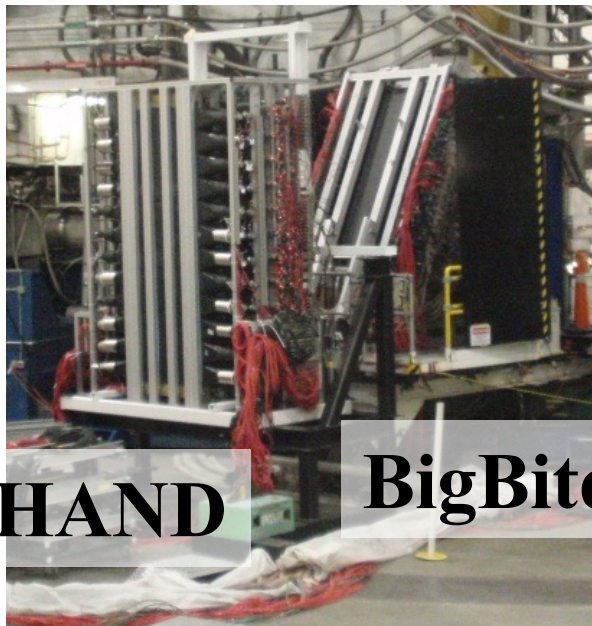
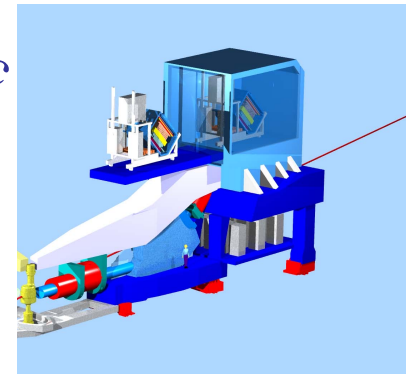
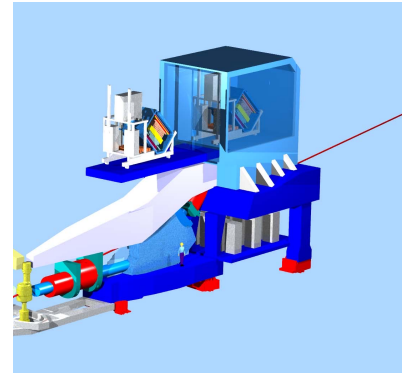
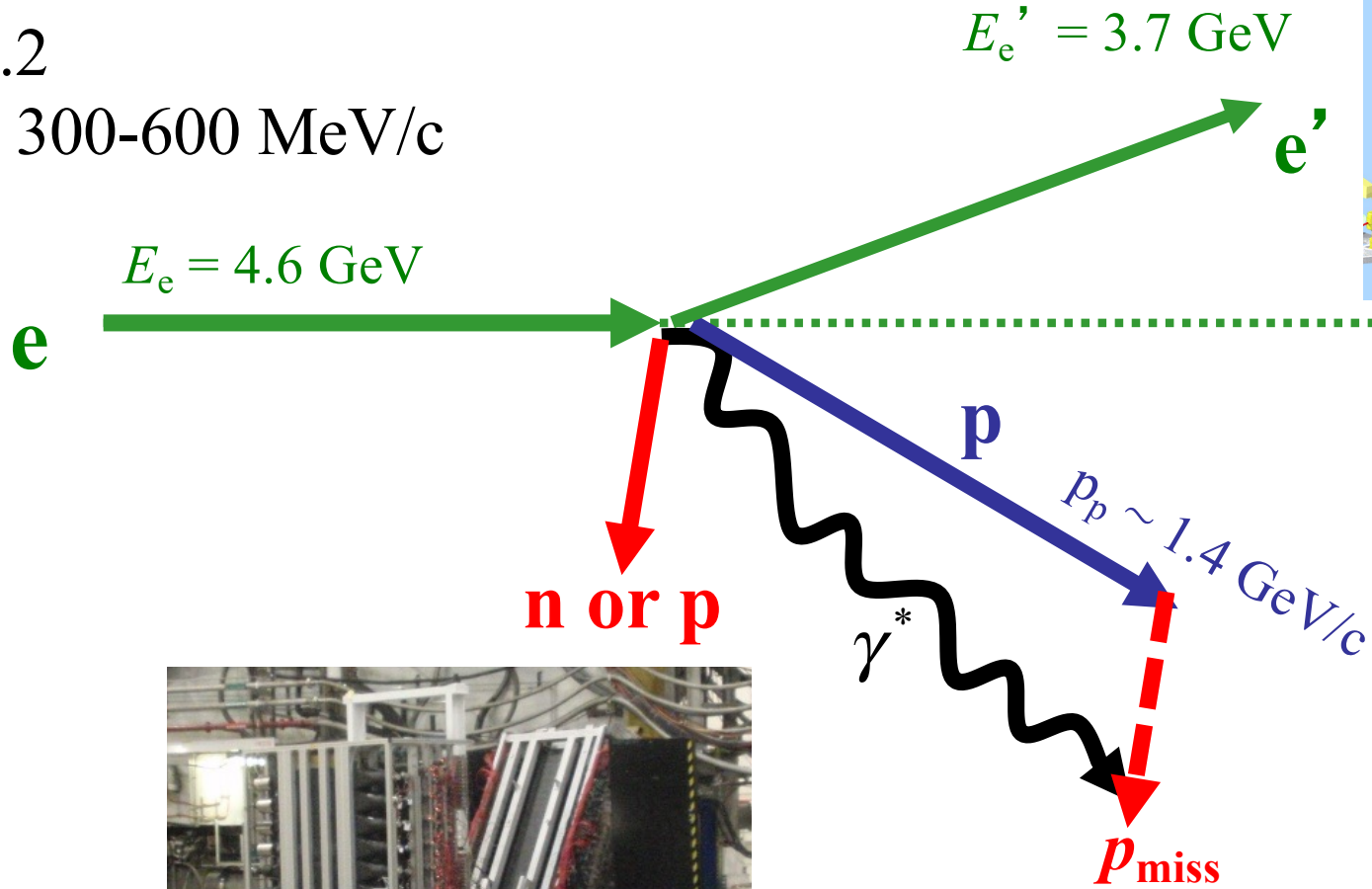

HAND

BigBite

Detect the proton,
look for its partner nucleon

High momentum protons have partners

$$C(e, e' pN) \text{ and } C(p, 2pn)$$

- Detect the knocked-out proton
- Look for partner nucleons
- ➔ All high-p protons have partners
- ➔ np pairs dominate at $0.3 < p_i < 0.6$

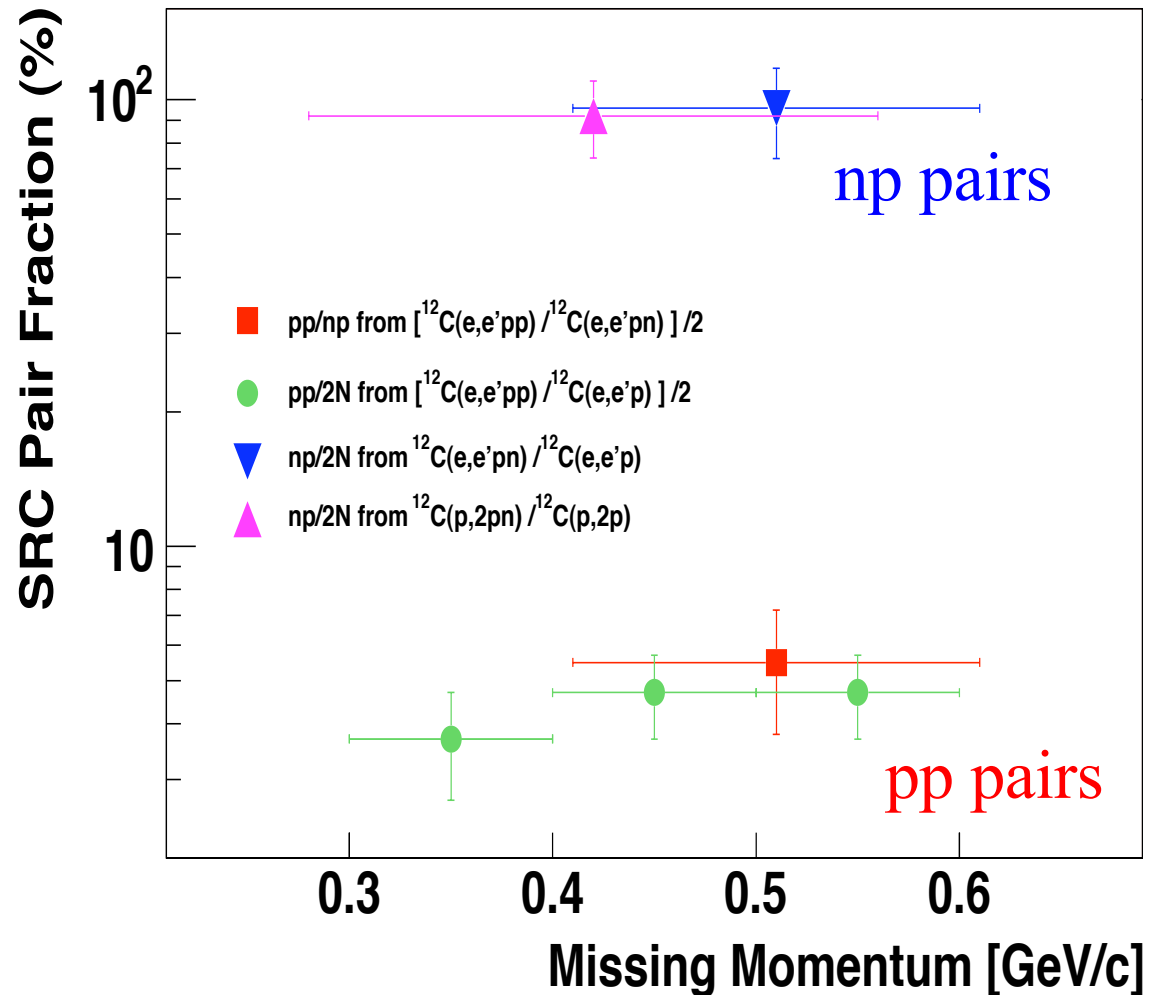
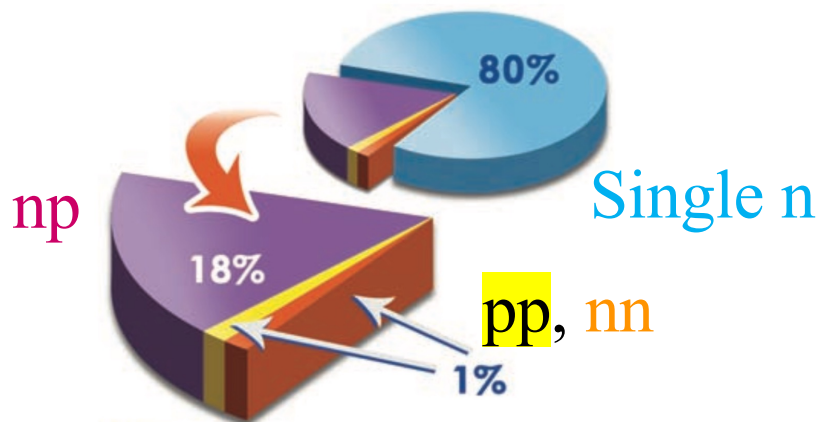

R. Subedi et al., Science 320, 1476 (2008)

CEBAF Large Acceptance Spectrometer [CLAS]

1997-2015

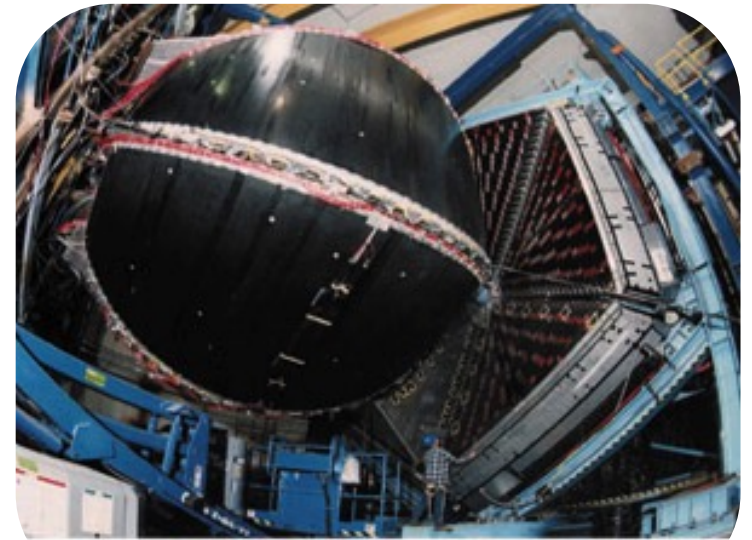
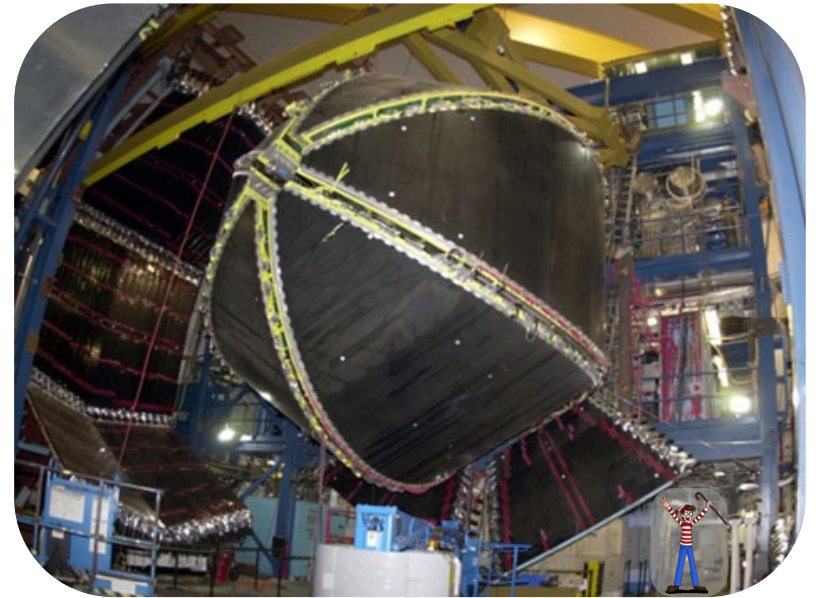
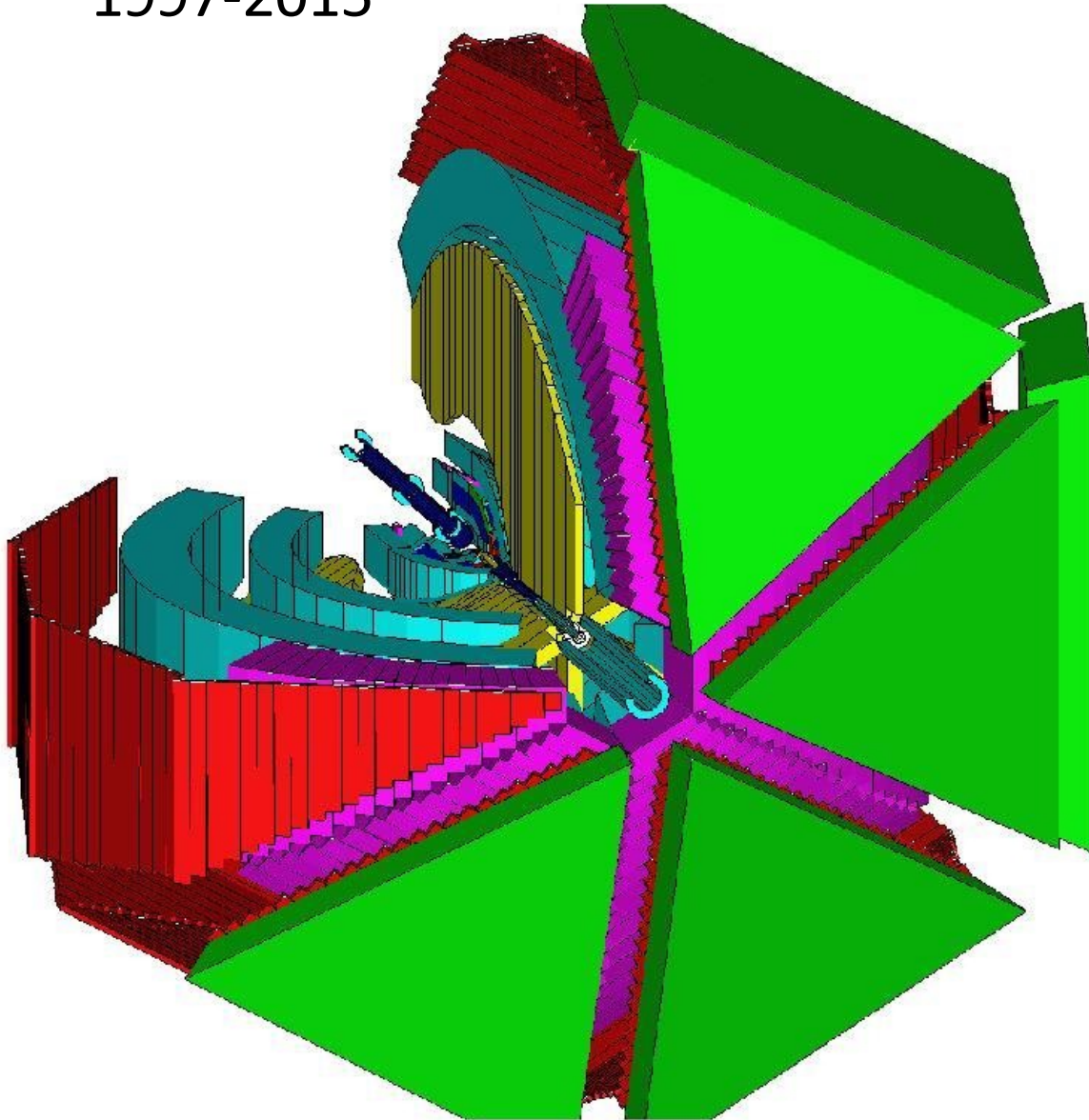

Hall B Large Acceptance Spectrometer

Open (e,e') trigger, Large-Acceptance, Low luminosity ($\sim 10^{34} \text{ cm}^{-2} \text{ sec}^{-1}$)

CEBAF Large Acceptance Spectrometer [CLAS]

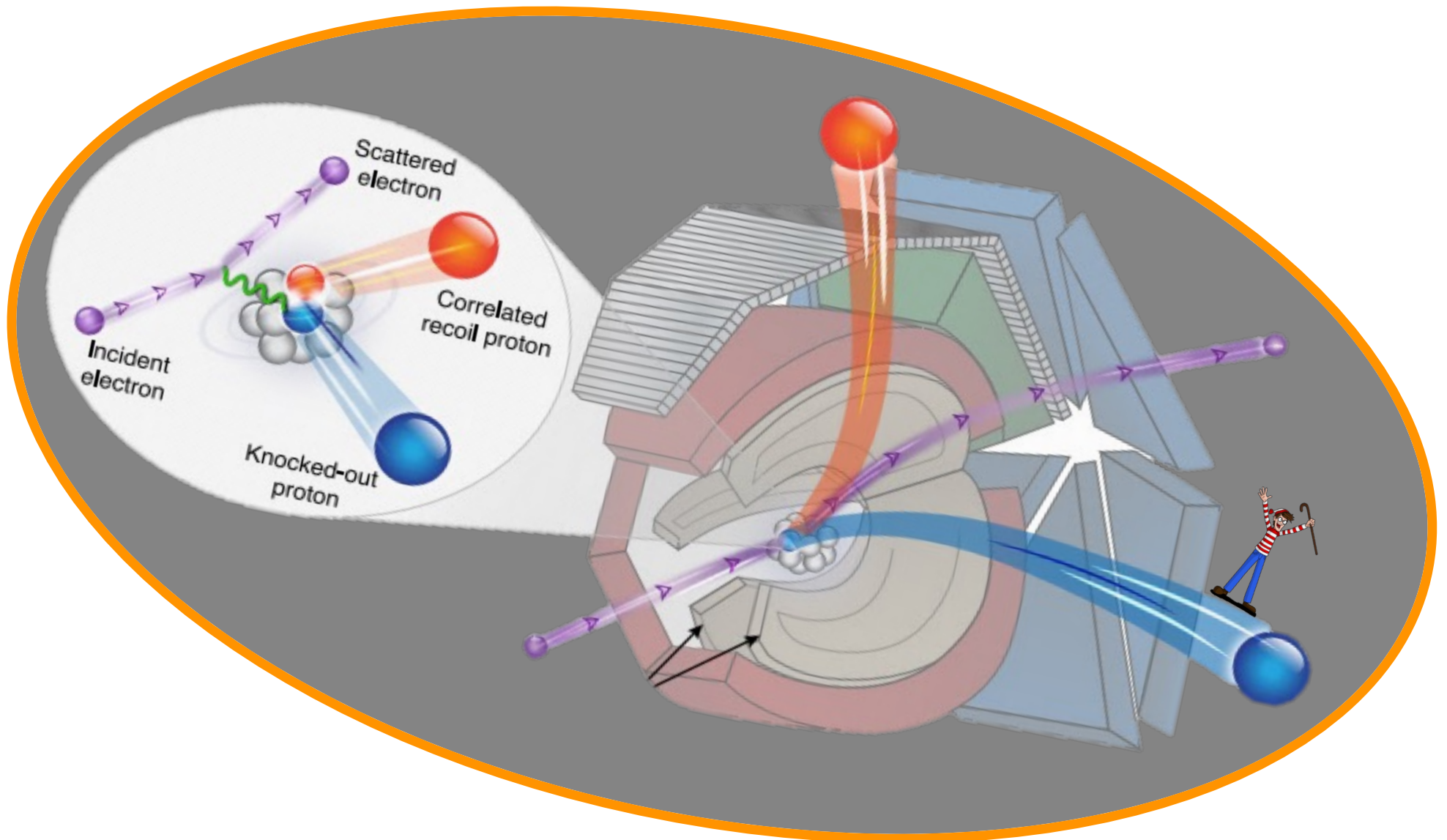

Open (e,e') trigger, Large-Acceptance, Low luminosity ($\sim 10^{34} \text{ cm}^{-2} \text{ sec}^{-1}$)

What about heavy nuclei?

- C, Al, Fe, Pb
- Detect the knocked-out proton
- Look for correlated proton partners

$$E_{beam} = 5 \text{ GeV}$$

$$x_B > 1.2$$

$$\rightarrow Q^2 > 1.5 \text{ GeV}^2$$

$$300 < p_{miss} < 600 \text{ MeV}/c$$

$$\theta_{pq} < 25^\circ$$

$$p_p/q \geq 0.6$$

$(e,e'pp)$ angular distributions

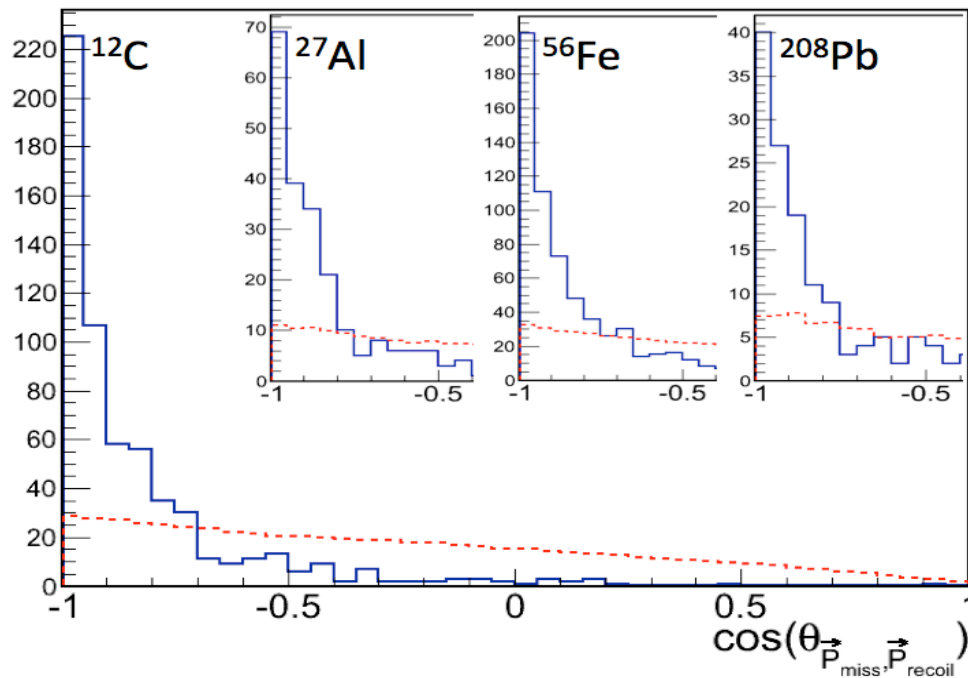

Angle between the $(e,e'p)$ missing momentum and the recoil proton momentum

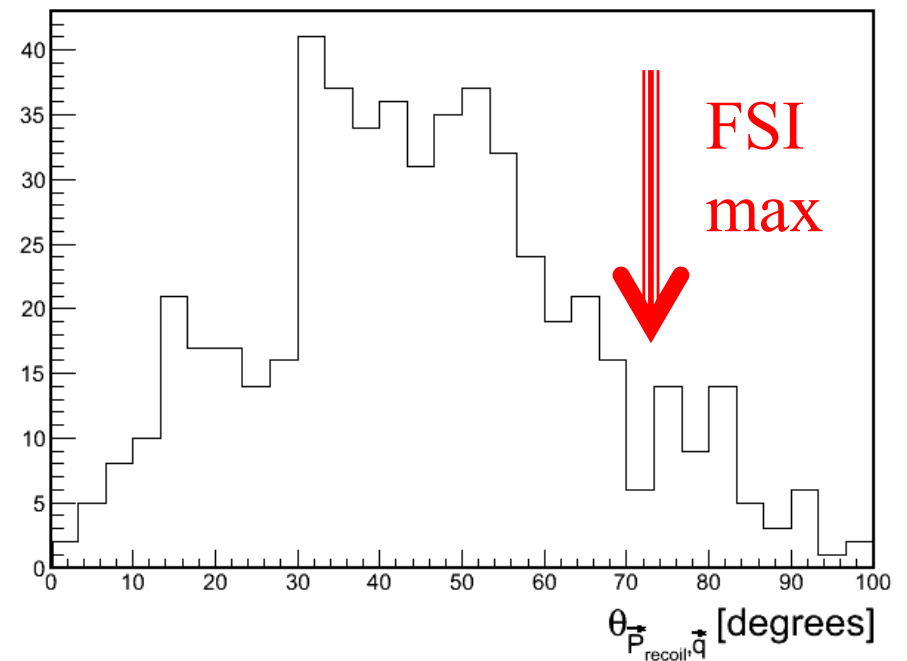

Angle between q and the recoil proton momentum

np and pp pairs

- Correct for proton rescattering via Glauber
- Assume all high- p_{miss} protons have a correlated partner
 - Not many partners are also protons
- \rightarrow High momentum tail still predominantly np

$$R = \frac{\frac{\sigma_A(e, e' pp)}{\sigma_A(e, e' p)}}{\frac{\sigma_C(e, e' pp)}{\sigma_C(e, e' p)}}$$

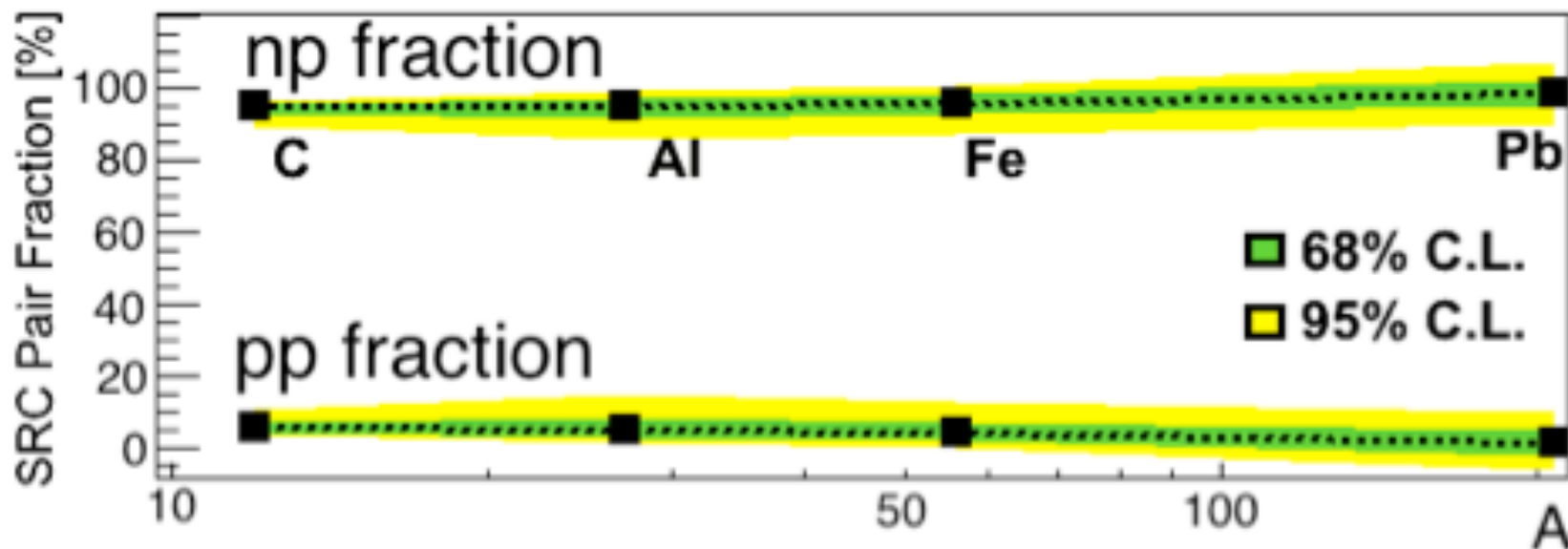

O. Hen *et al*, Science **346** 614 (2014)

Asymmetric nuclei: Momentum inversion?

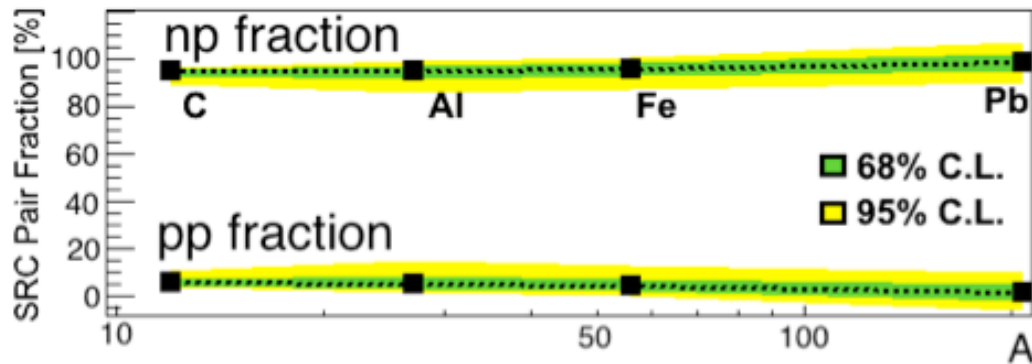

O. Hen *et al*, Science **346** 614 (2014)

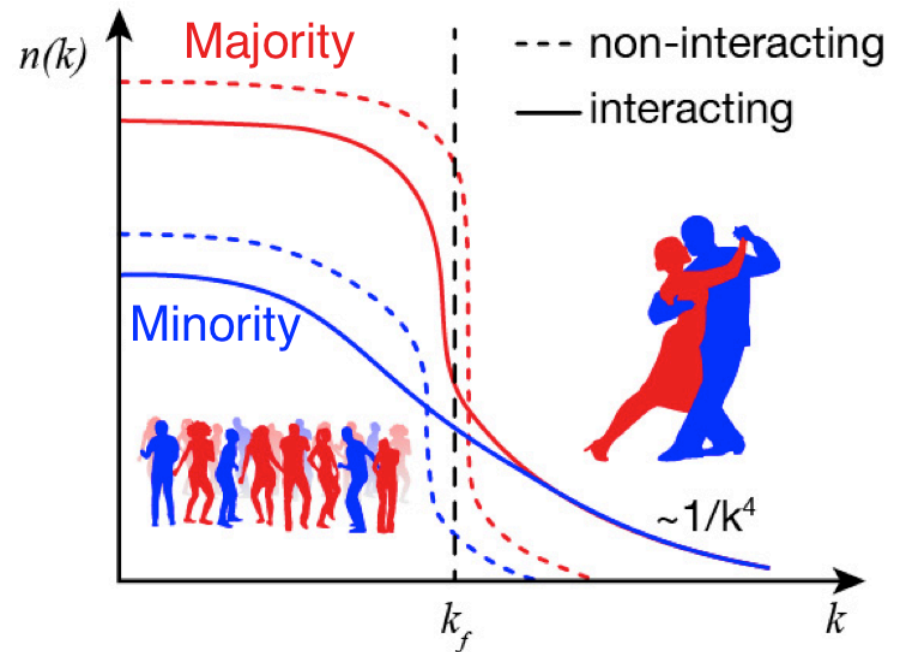

Asymmetric nuclei:

np pairs still dominate the high momentum tail, even in neutron-rich nuclei such as Pb

→ higher probability for each proton to be in tail

Proton vs. Neutron Knockout

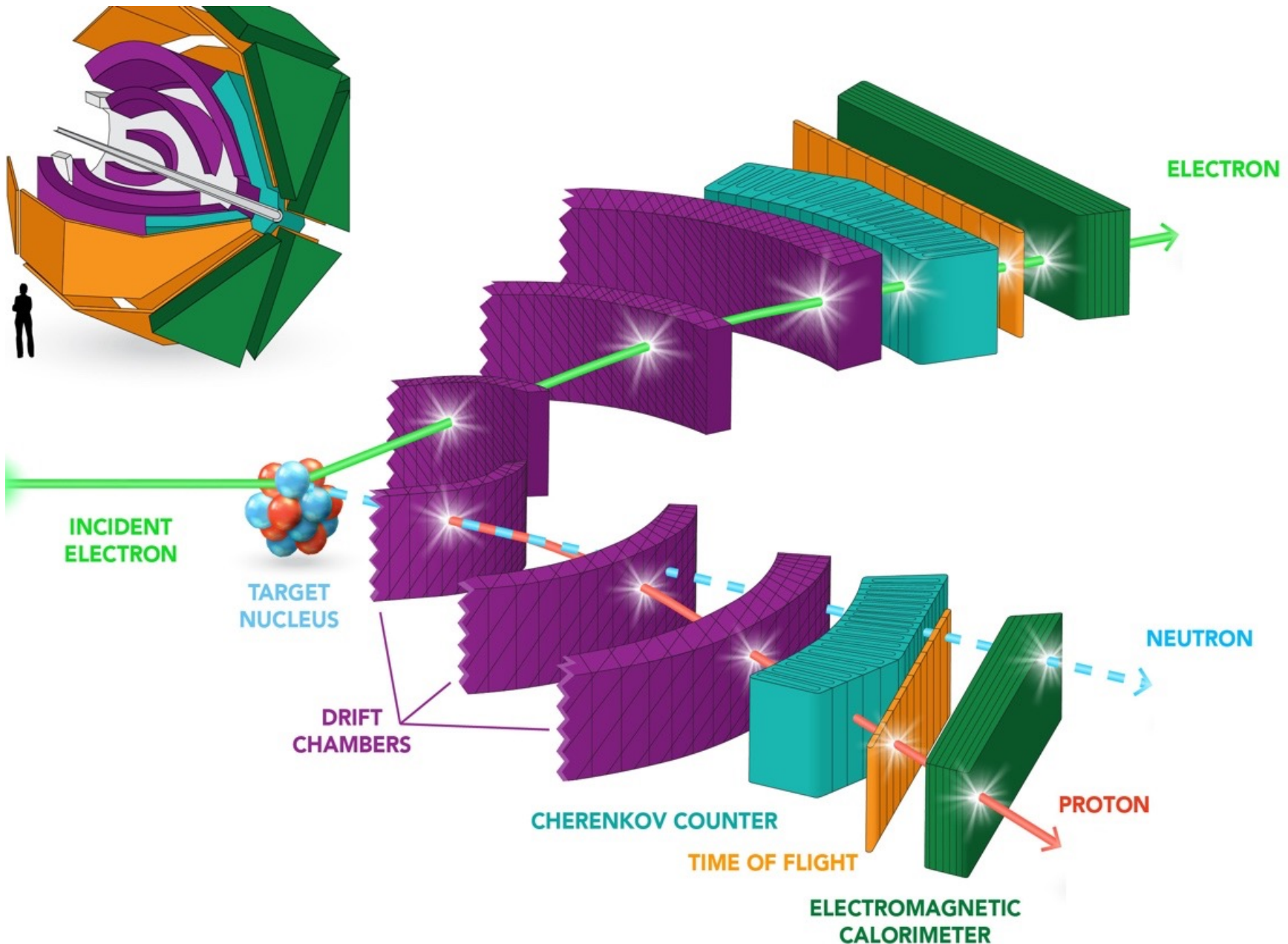

Which nucleons pair?

“Low momentum”: $E_{\text{miss}} < 80 \text{ MeV}$, $p_{\text{miss}} < 250 \text{ MeV}/c$

“High momentum”: $p_{\text{miss}} > 300 \text{ MeV}/c$

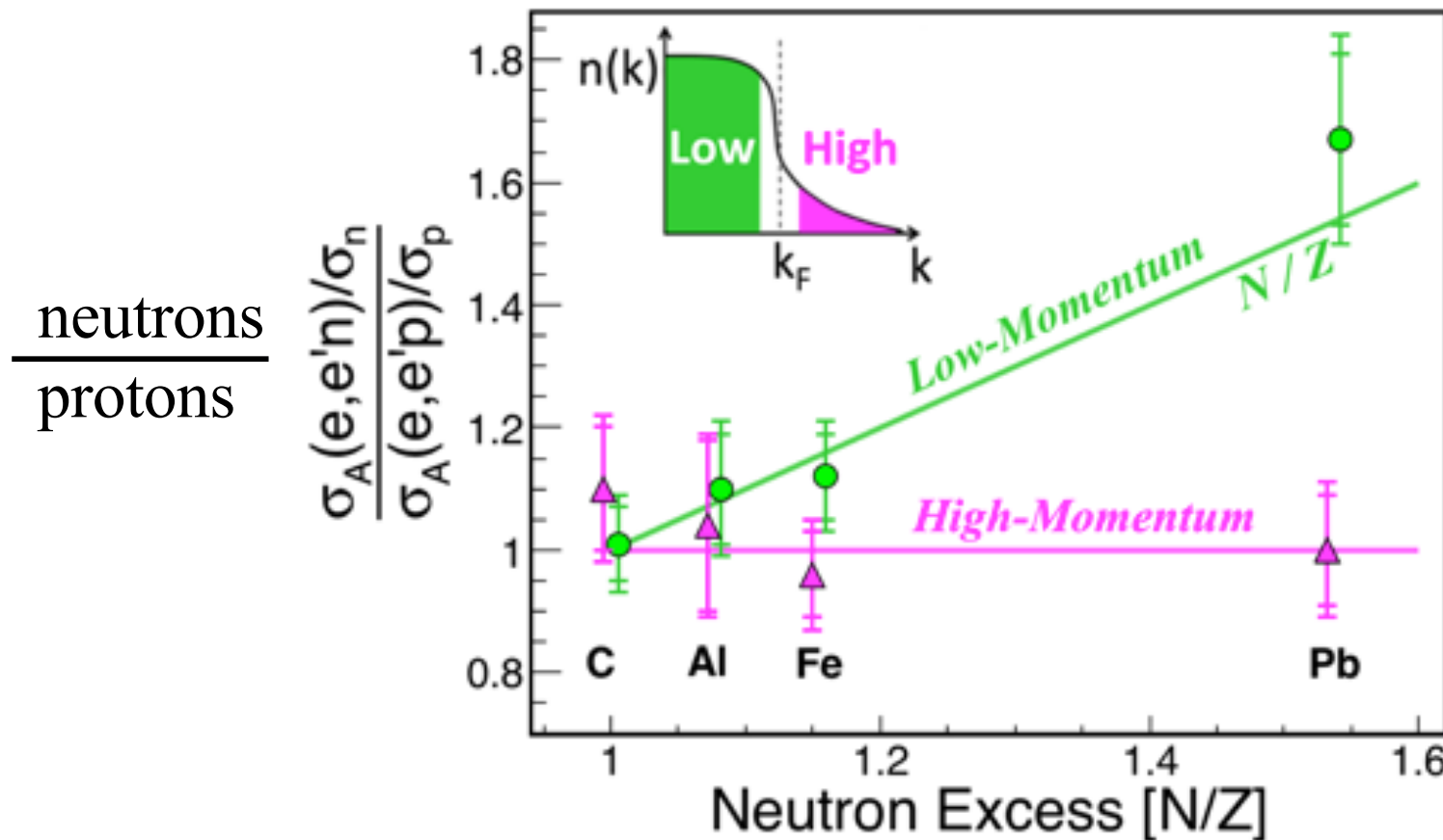

Same # of high-momentum protons and neutrons

Which nucleons pair?

Correlation Probability:

Neutrons saturate, Protons grow

$\frac{\text{Hi-mom}}{\text{Lo-mom}}$

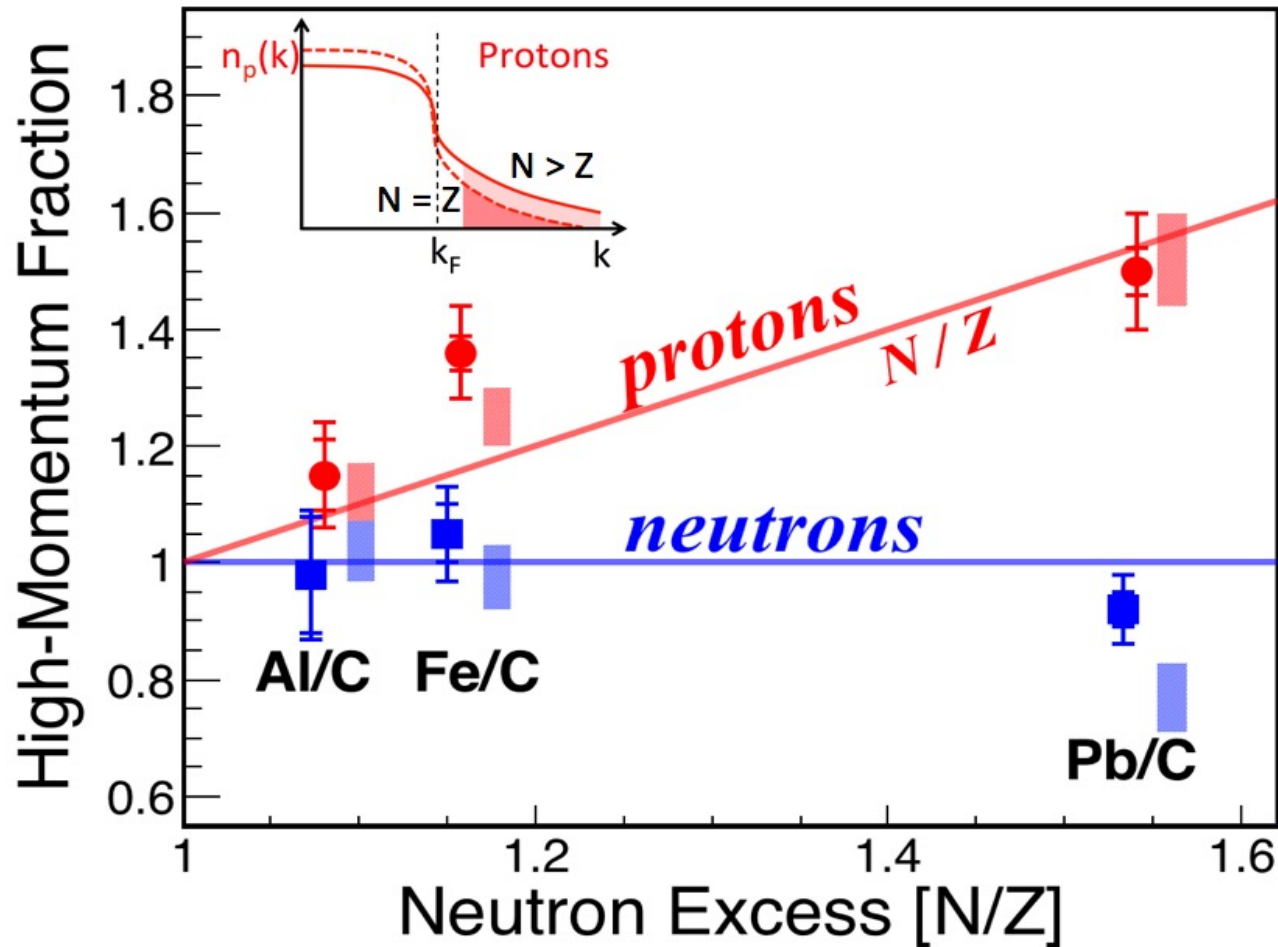

Why do np pairs dominate?

pp pairs in an s-wave

s-wave momentum distribution minimum at $p \approx 400$ MeV/c
 np minimum filled in by tensor correlations

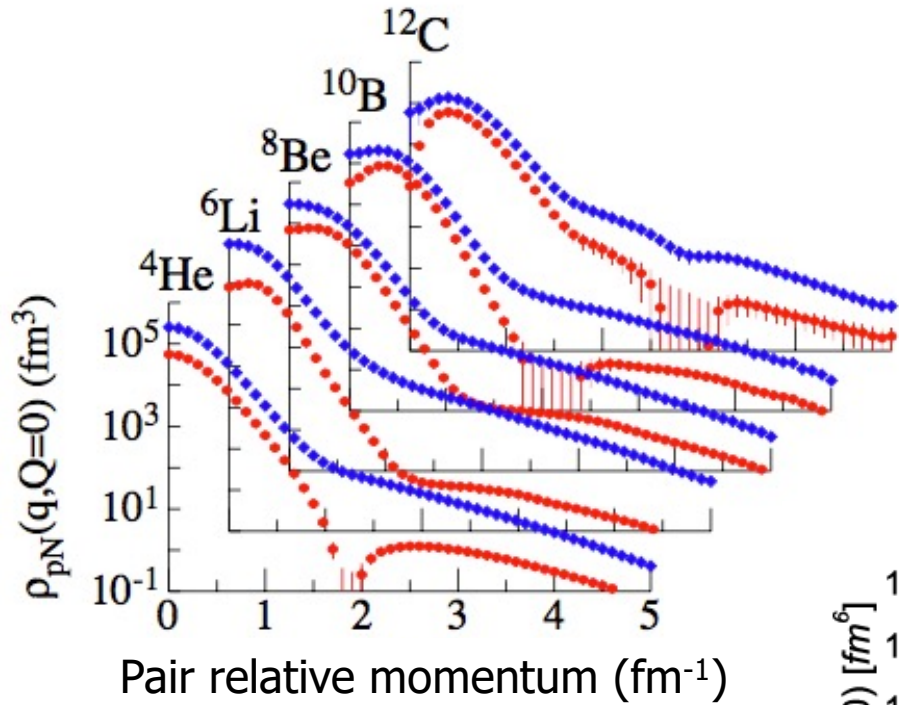

Carlson et al., RMP **87** (2015) 1067

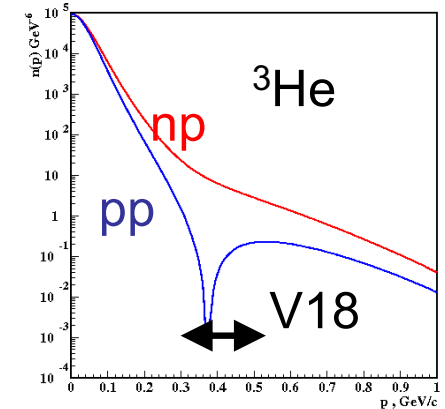

Pair relative momentum

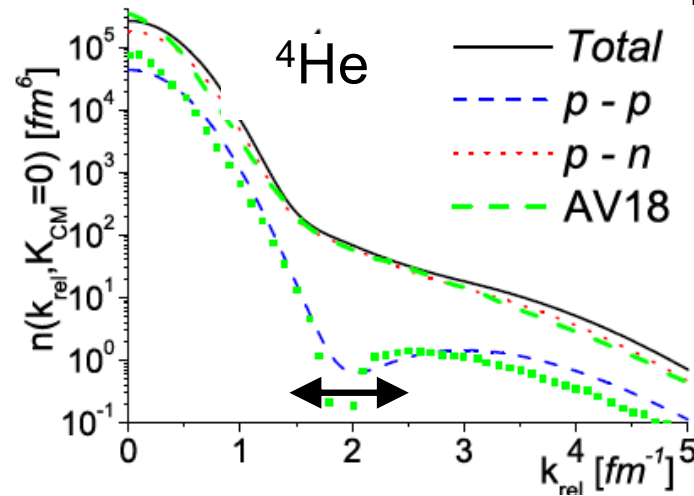

Pair relative momentum

Ciofi and Alvioli
 Gent workshop, Aug. 2007

Sargsian, Abrahamyan, Strikman, Frankfurt
 PRC **71**, 044615 (2005).

Now go past the $p \sim 0.4$ GeV/c minimum

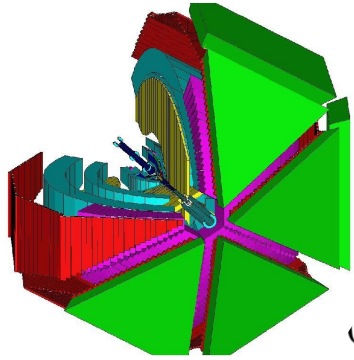

$$\frac{{}^{12}\text{C}(e, e'pp)}{{}^{12}\text{C}(e, e'p)}$$

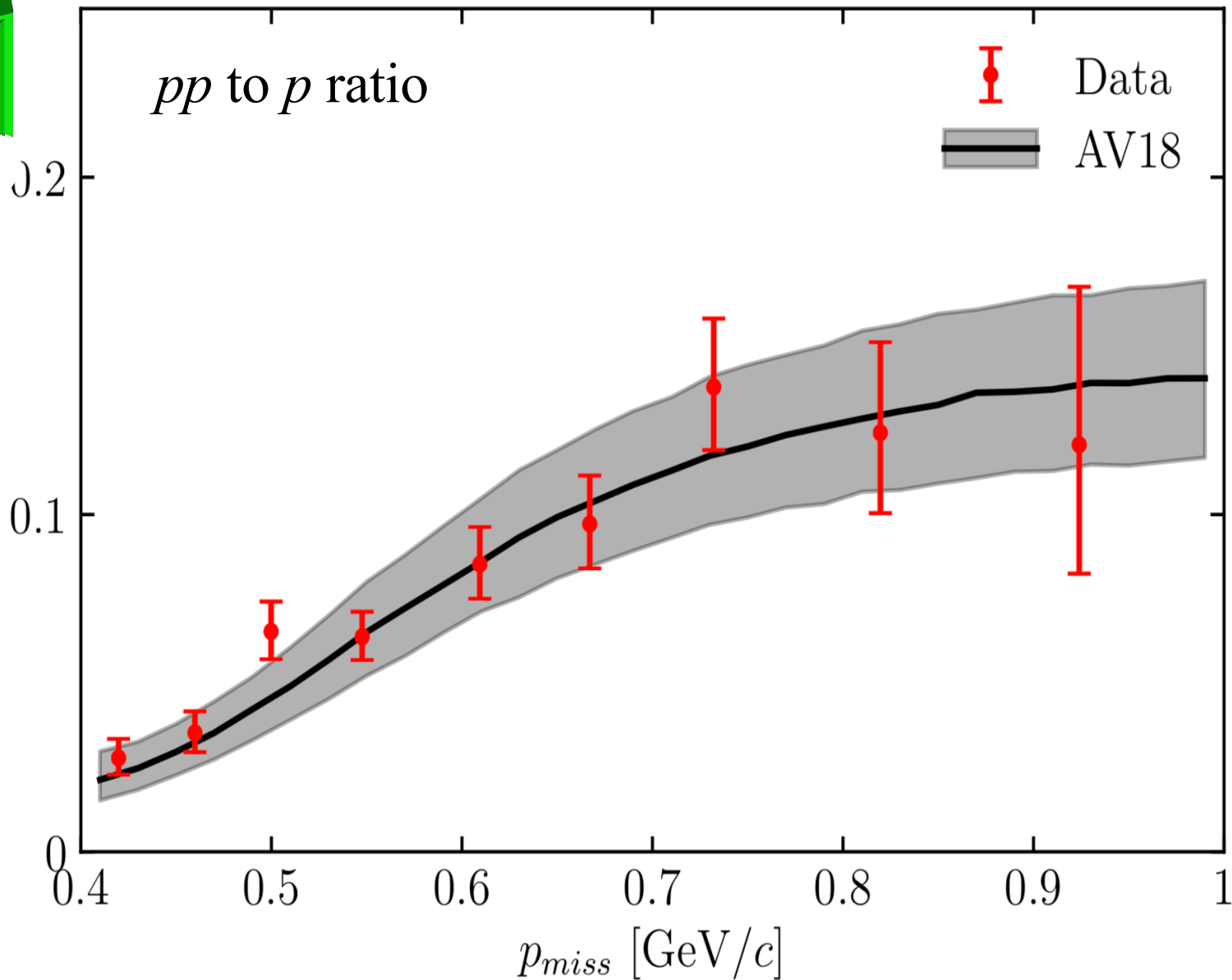

Schmidt et al., Nature (2020)

Reaching the Repulsive Core

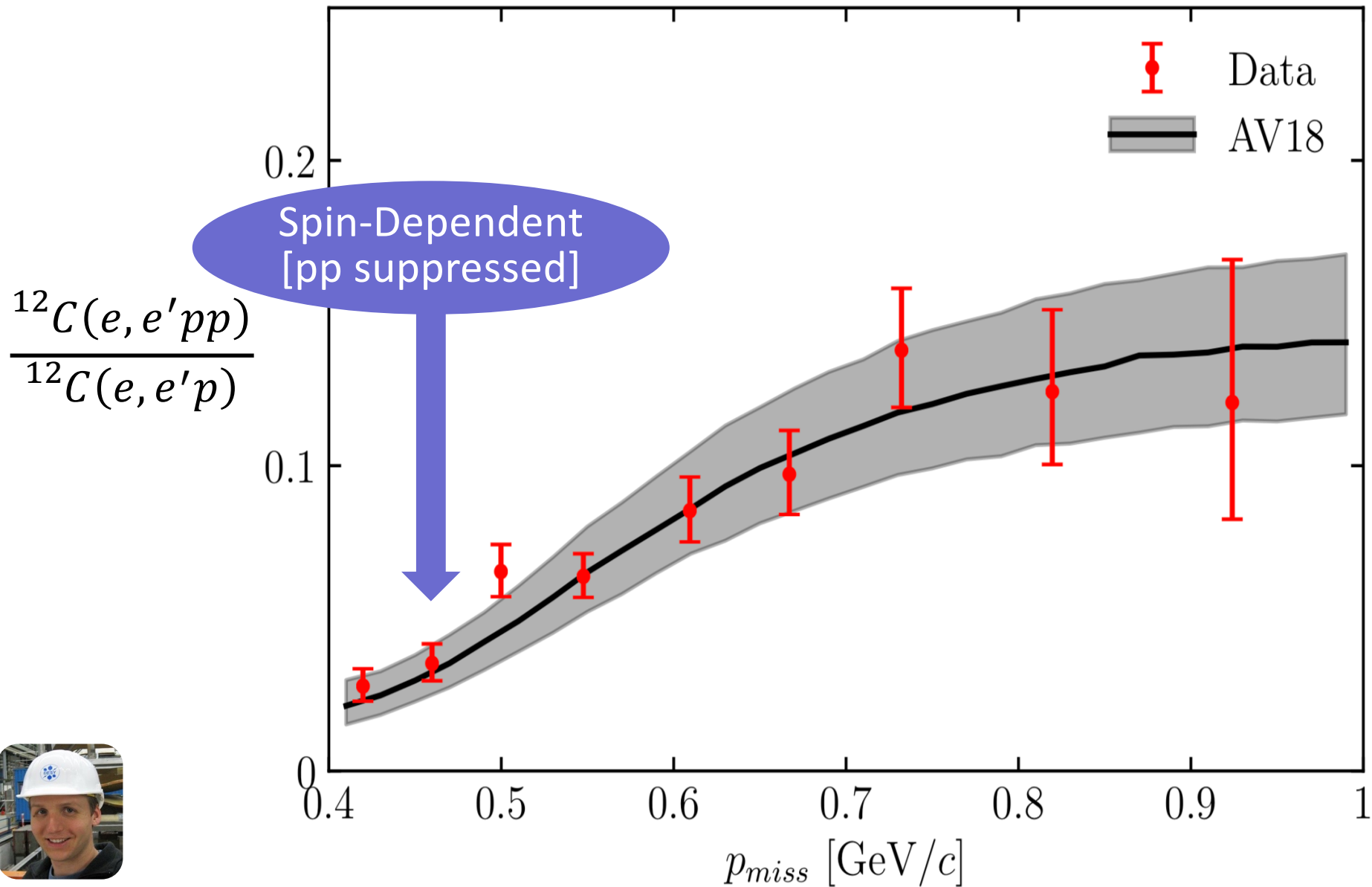

Schmidt et al., Nature (2020)

Reaching the Repulsive Core

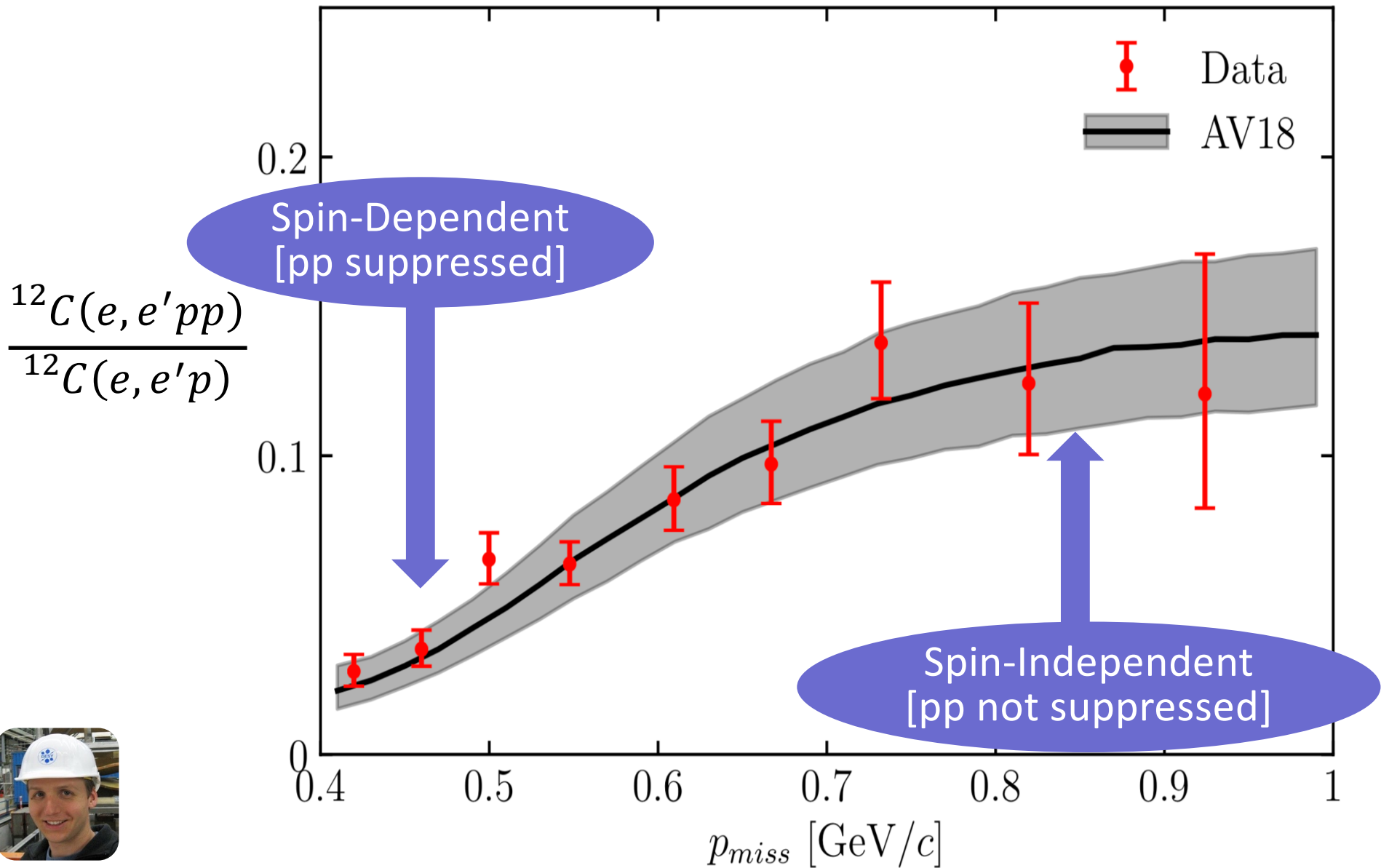

Schmidt et al., Nature (2020)

Reaching the Repulsive Core

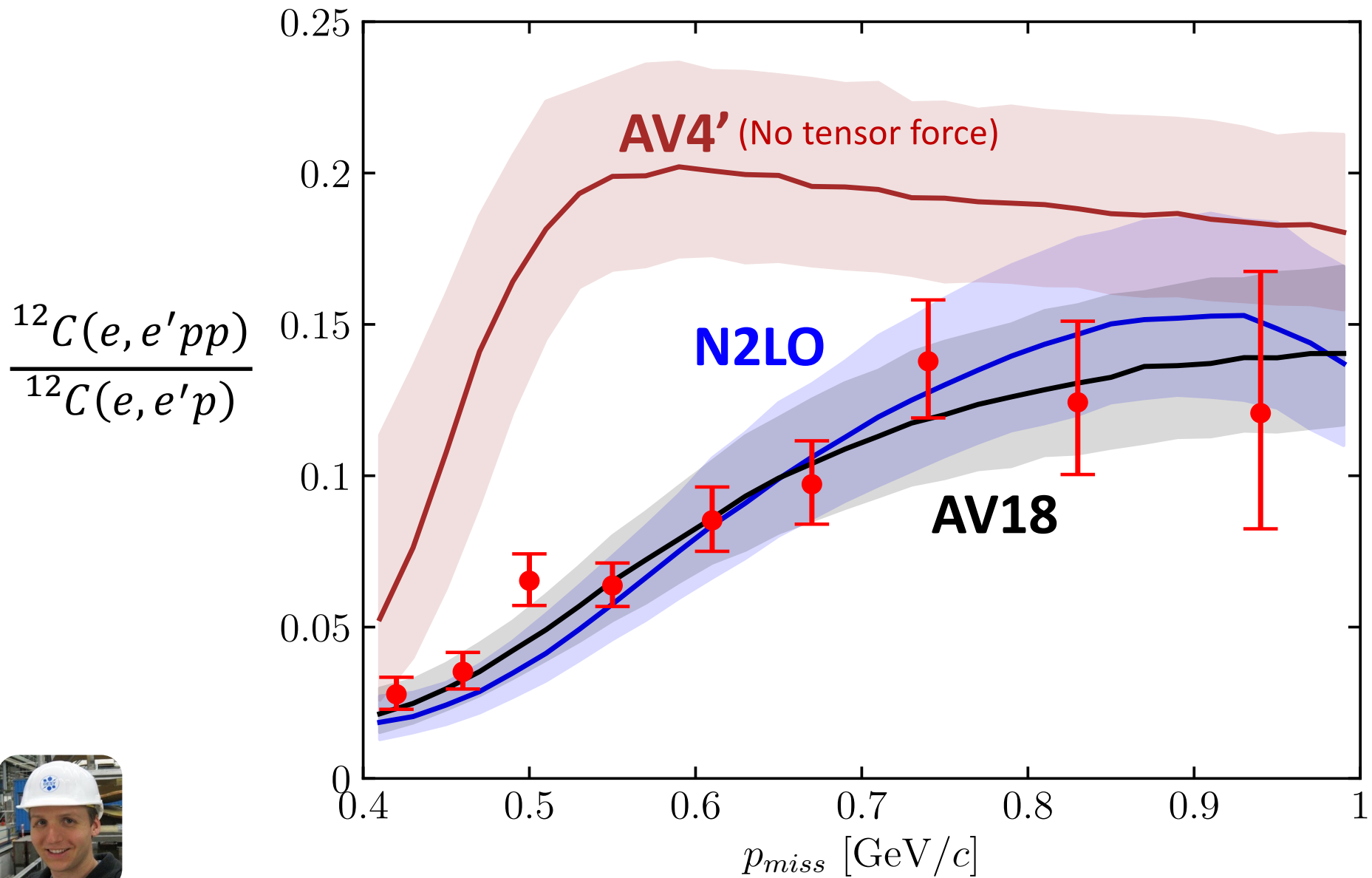

Schmidt et al., Nature (2020)

What we've learned

- Nuclear momentum distribution has two distinct regions.
 - Correlated region is *scale separated* from the many-body region.
 - Narrow transition region
- Almost all high-momentum nucleons are in SRC pairs
- SRC pairs are predominantly np pairs due to the NN tensor force
 - Protons more correlated than neutrons in neutron-rich nuclei
 - Transition to central force at higher momenta

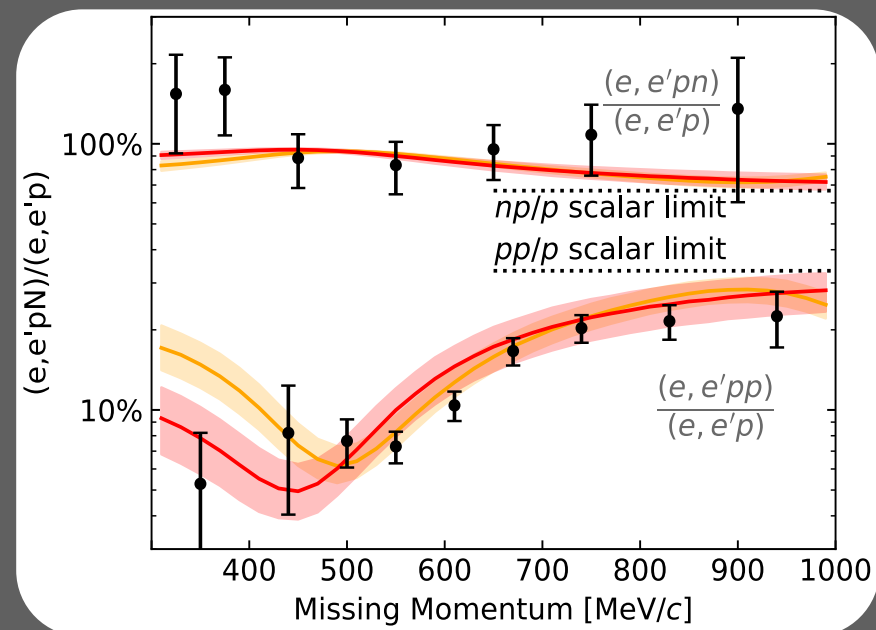

What next?

White Paper open questions:

- 3N SRCs
- Modified nucleon structure
- Accuracy of factorized cross section models
- Quantify the connection between data and the nuclear ground state
- Theory
 - Ground state models
 - Reaction modeling

This workshop:

- Which nucleons form pairs?
 - (e,e') , $(e,e'p)$, $(e,e'pN)$
- Theory
- SRC Universality
- Search for 3N SRCs
- SRCs and nucleon modification

Thank You!

